

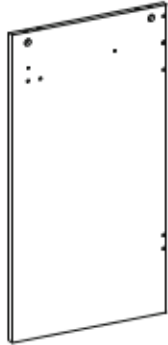

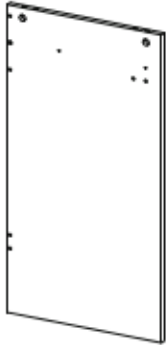

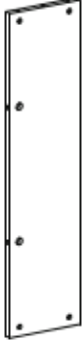

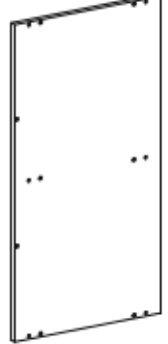

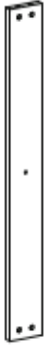

<p>A  x 1</p>	<p>B  x 1</p>
<p>C  x 1</p>	<p>D  x 1</p>
<p>E  x 1</p>	<p>F  x 1</p>
<p>G  x 1</p>	<p>H  x 1</p>

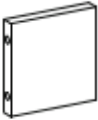
<p>I × 2</p> 	<p>J × 2</p> 
<p>K × 1</p> 	<p>L1 × 1</p> 
<p>L2 × 1</p> 	<p>L3 × 1</p> 
<p>M × 1</p> 	<p>N × 1</p> 

O

x 2

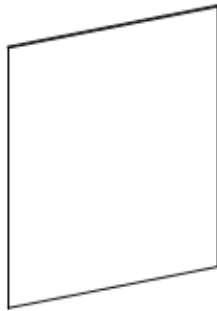

P

x 2



Q

x 2



R

x 2



CL

CR

DL

DR



x 2

x 2

x 2

x 2

1



22+1

2



28+1

3



28+1

4



× 2

5



2+1

6

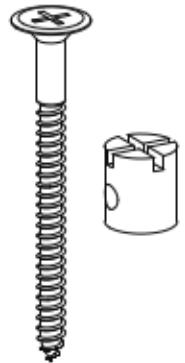

12+1

7



9+1

8



48+2

9



4+1

10

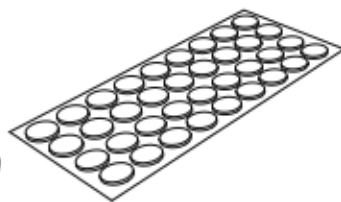

× 1

11

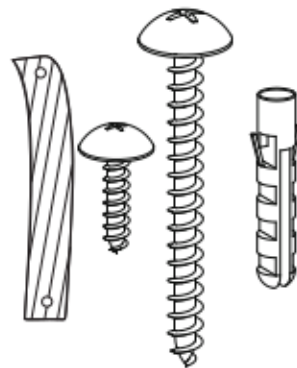

× 1

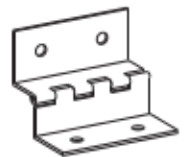

12

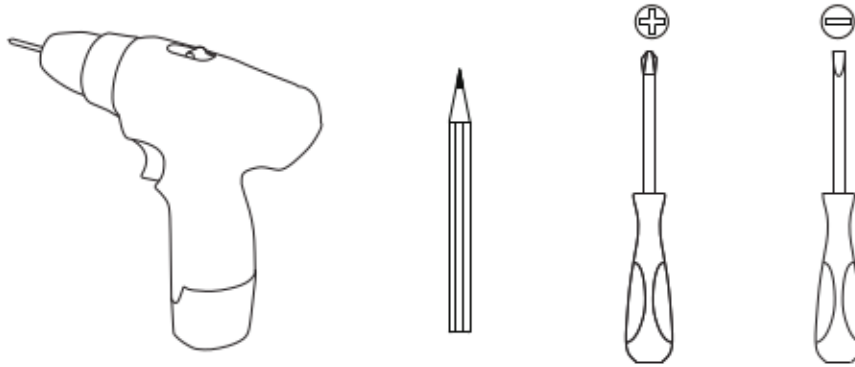

× 4

Tools Required:



	Bolt	Perno
	Bolzen	Bout
	Boulon	Bult
	Boulon	Wkręt
	Connecting piece	
	Verbindungsbeschlag	
	Plèce de raccord	
	Pezzo di bloccaggio	
	Pieza de sujeción	
	Verbindingsonderdeel	
	Anslutningsstycke	
Element połączeniowy		

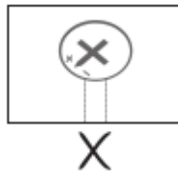

Adjust connecting piece direction until it is properly lined up with the hole.

Stellen Sie den Verbindungsbeschlag so ein, dass er wie im Bild gezeigt ausgerichtet ist.

Ajustez l'écrou selon le schéma.

Regolare la direzione di pezzo di collegamento come la condizione illustrata.

Ajustar la pieza de sujeción según la dirección ilustrada.

Pas de richting van de verbindings onderdelen aan tot het goed is gealigneerd met het gat.

Justera anslutningsstyckets riktning tills det är korrekt inriktat med hålet.

Ustaw element połączeniowy do momentu, gdy jest on na linii z otworem.

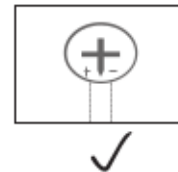

Insert bolt when connecting piece direction is properly lined up.

Setzen Sie erst dann den Bolzen ein.

Insérez le boulon quand la pièce de raccord est dans telle condition.

Inserire il bullone quando il pezzo di collegamento è in tale condizione.

Insertar el perno cuando se encuentre así la pieza de sujeción

Plaats bout wanneer de richting van het verbindingsdeel goed is gealigneerd.

Sätt in bulten när anslutningsstycket är korrekt inriktat.

Wsuń wkręt kiedy kierunek elementu połączeniowego został poprawnie ustawiony.

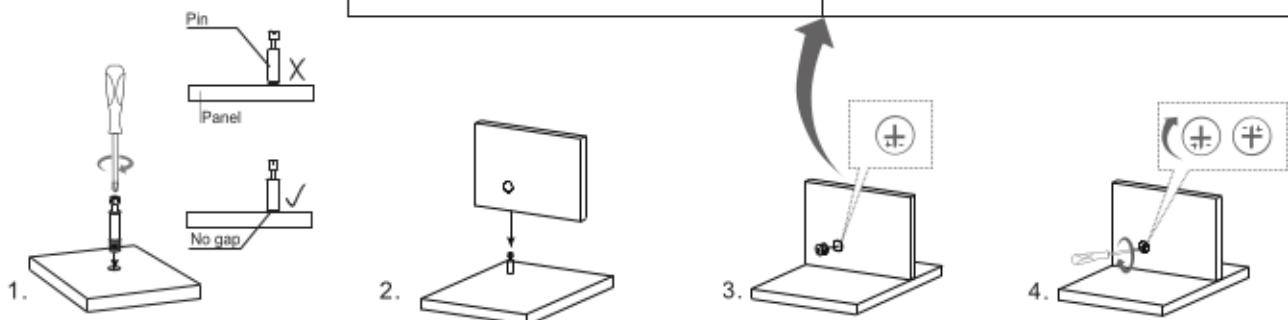

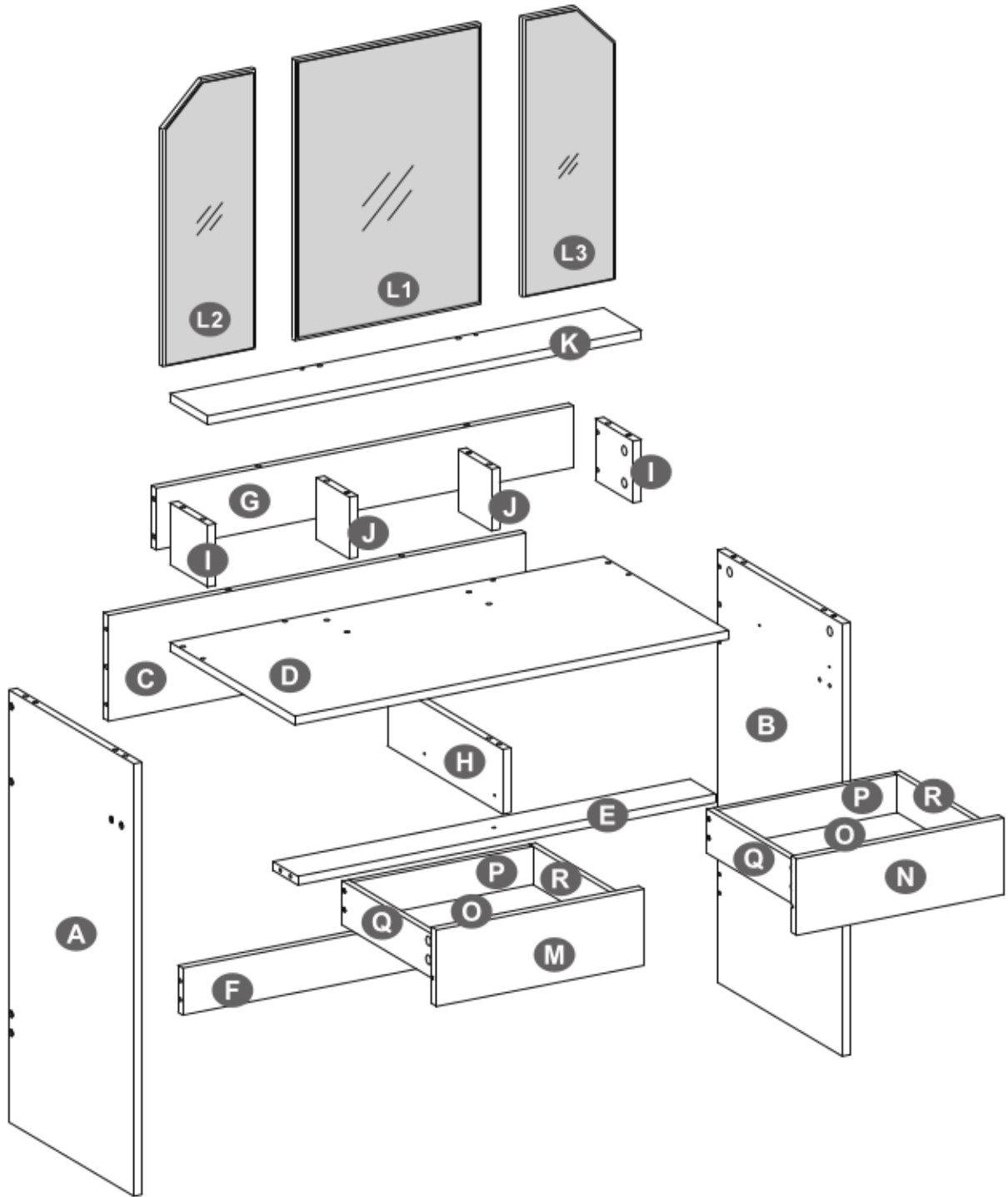

1

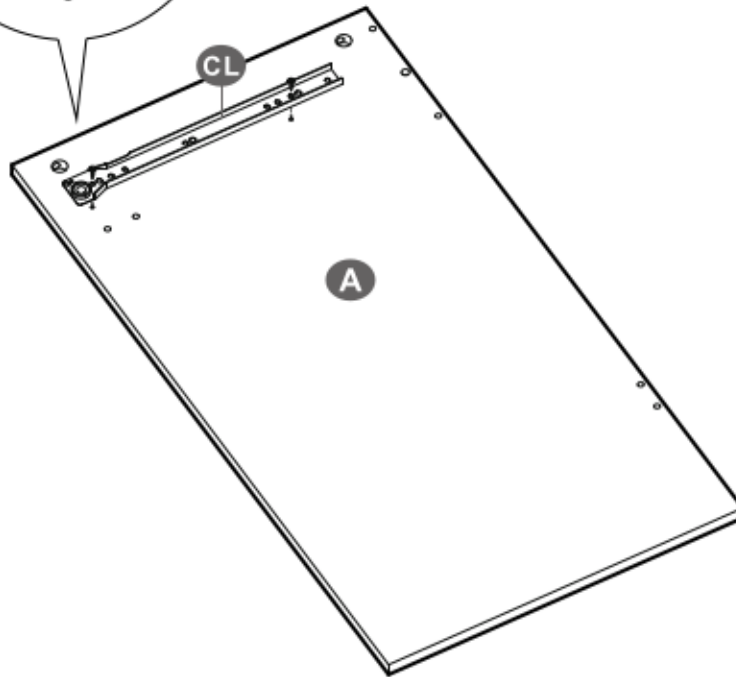
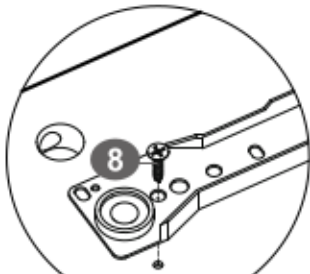
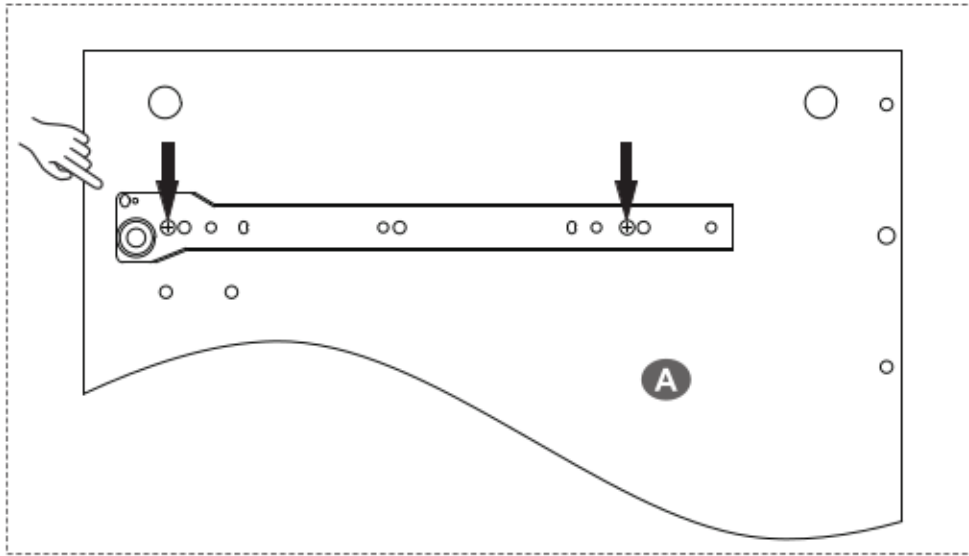

8



× 2

2

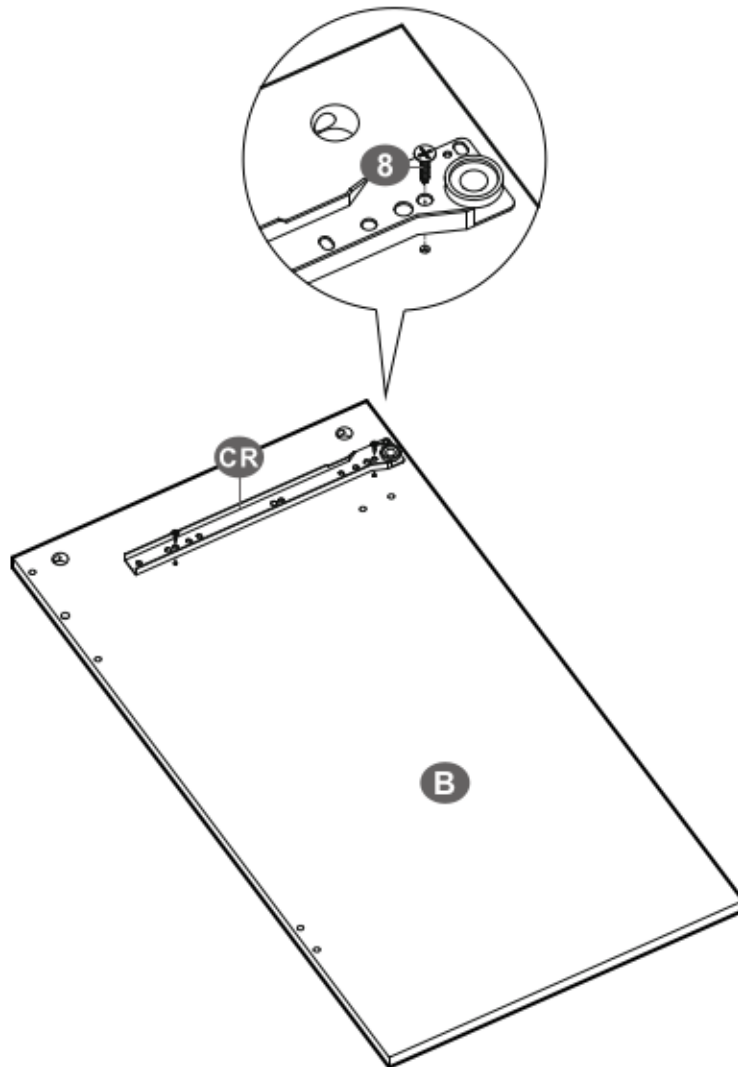
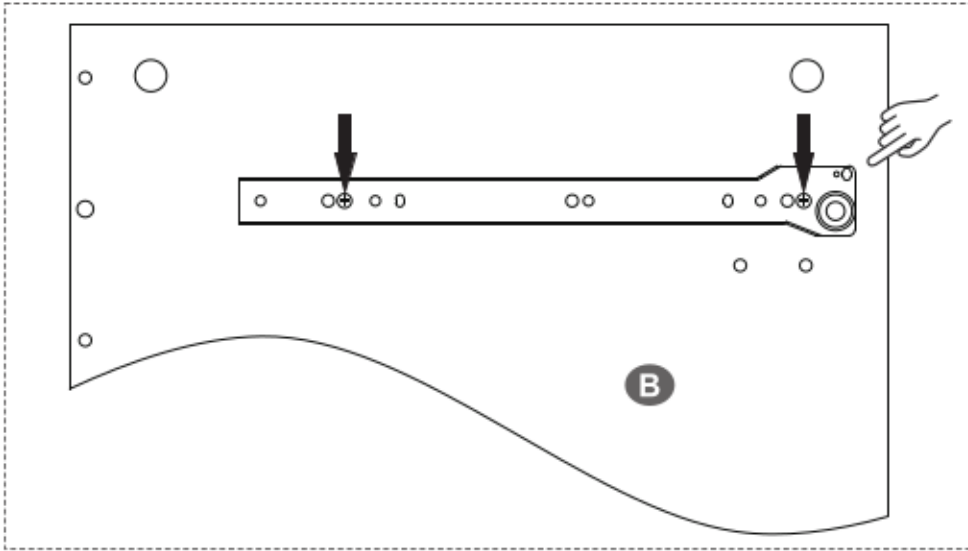

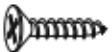
8  × 2

3

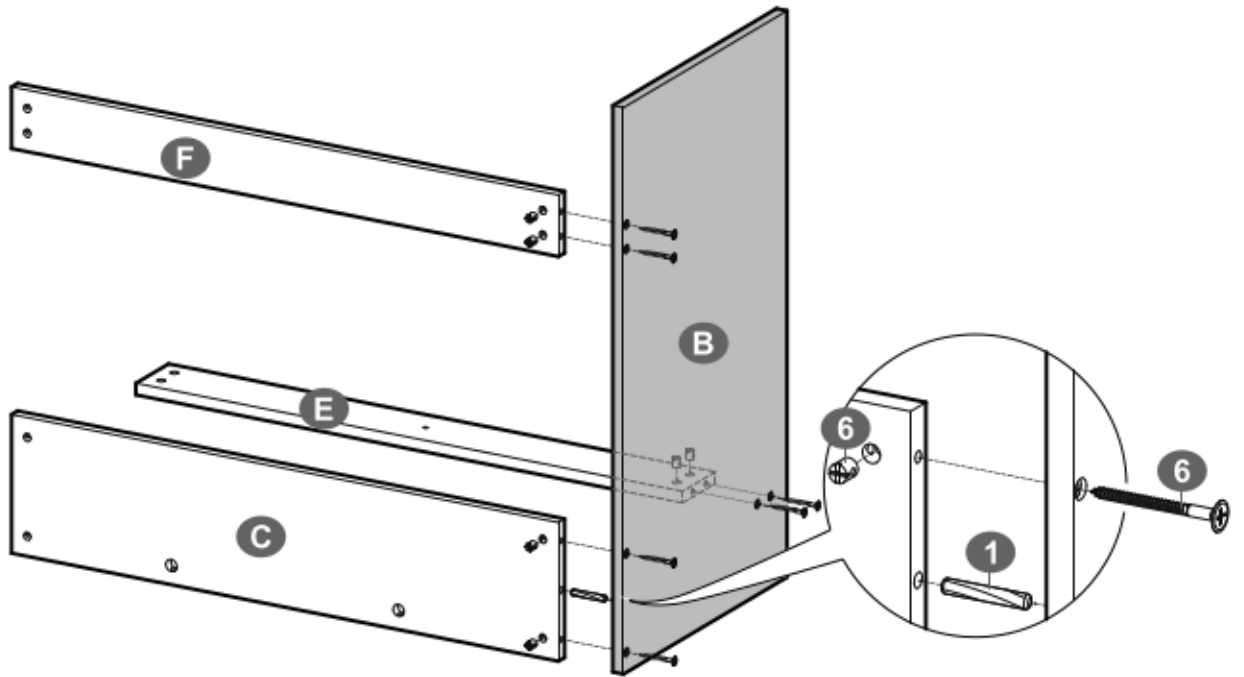

1



× 1

6



× 6

4

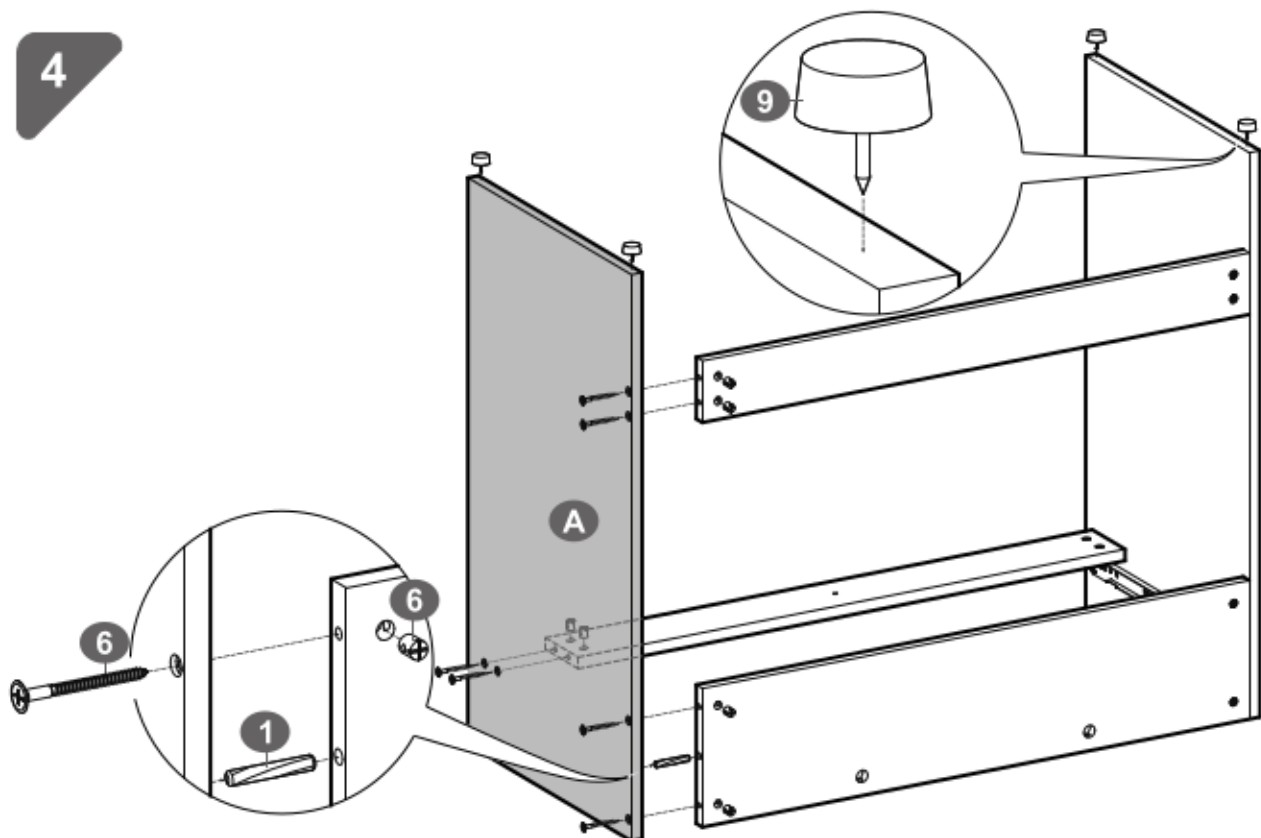

1

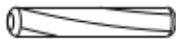

× 1

6



× 6

9



× 4

5

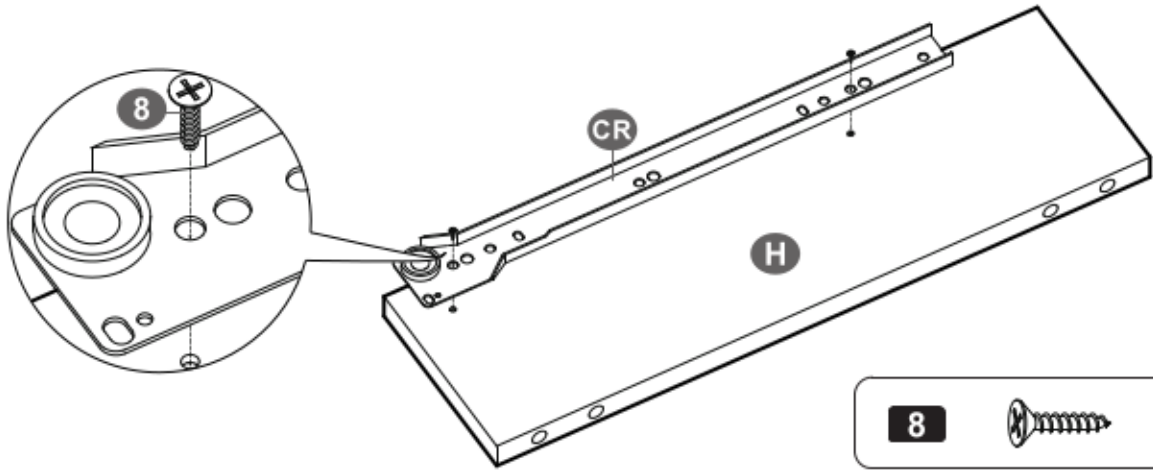
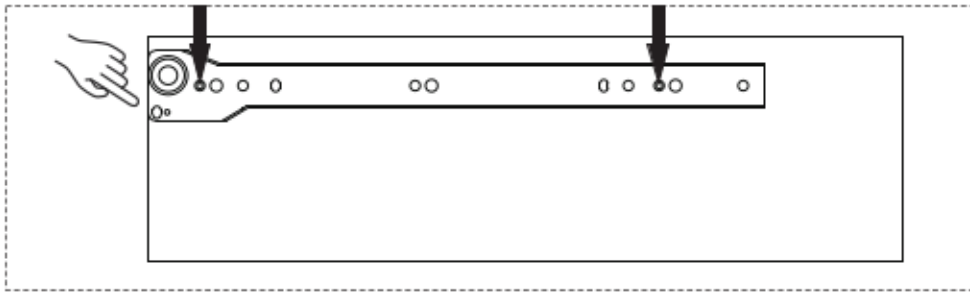

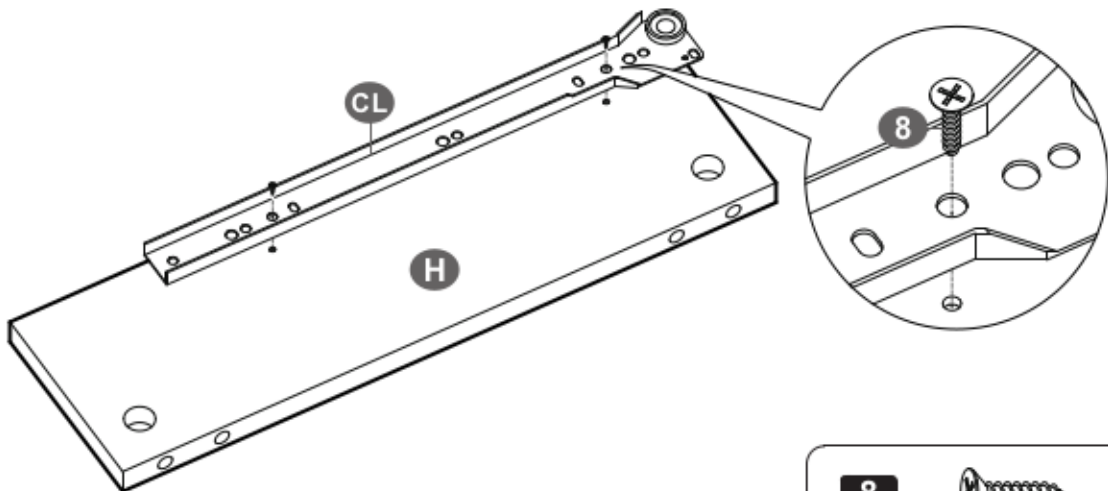
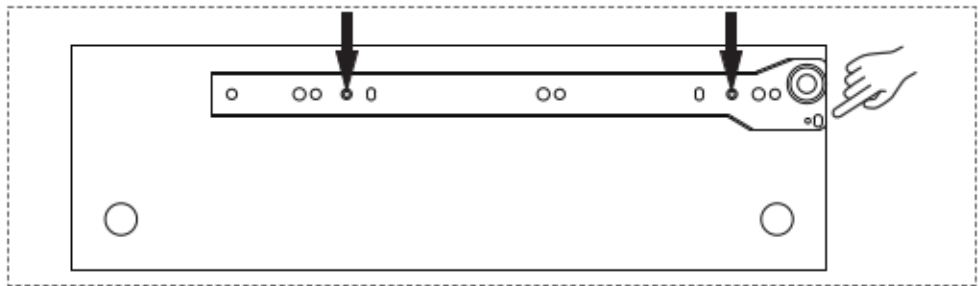

6

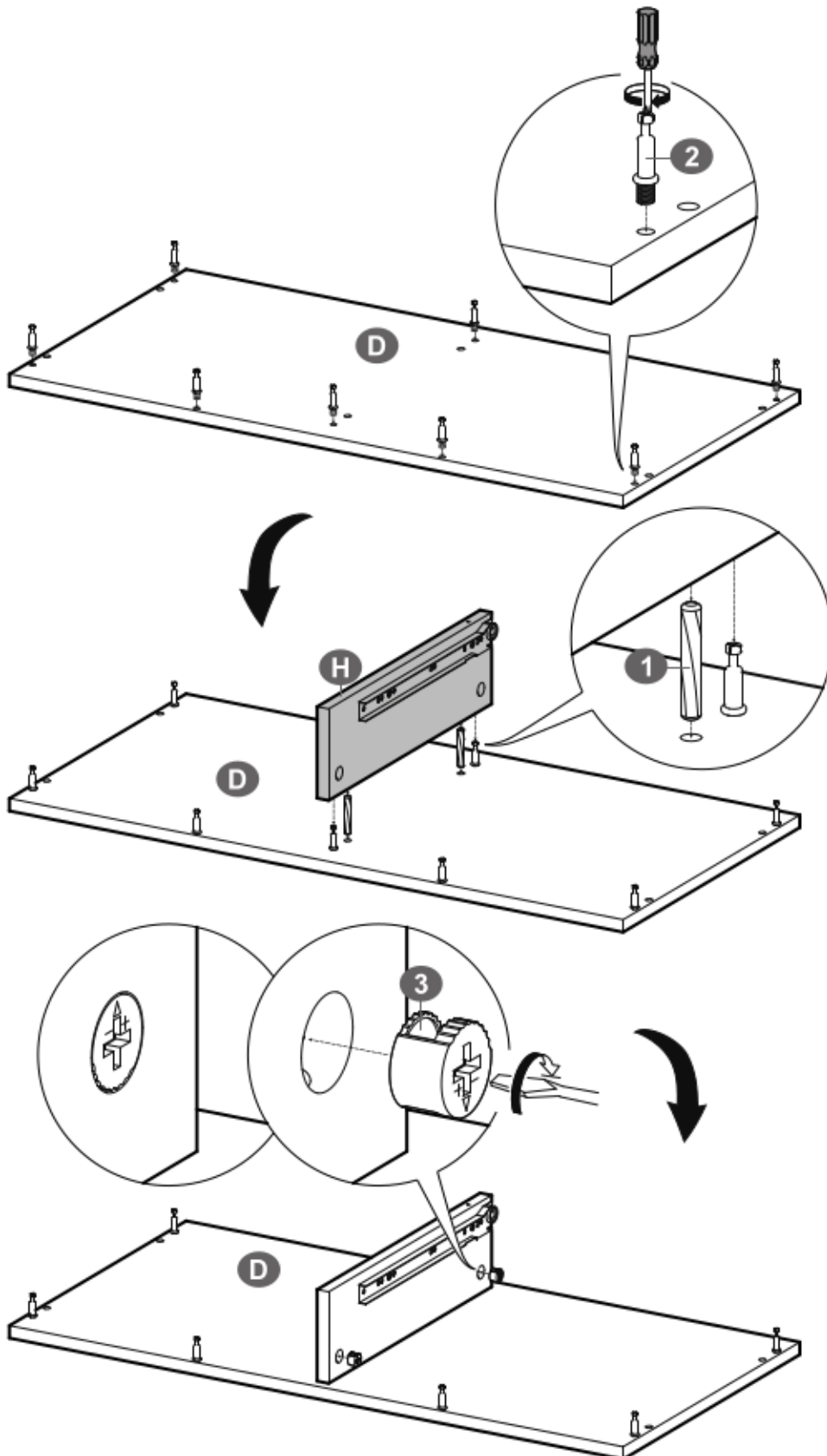

7

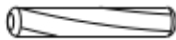
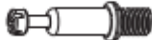

- | | | | | | | | | |
|----------|---|-----|----------|---|-----|----------|---|-----|
| 1 |  | × 2 | 2 |  | × 8 | 3 |  | × 2 |
|----------|---|-----|----------|---|-----|----------|---|-----|

8

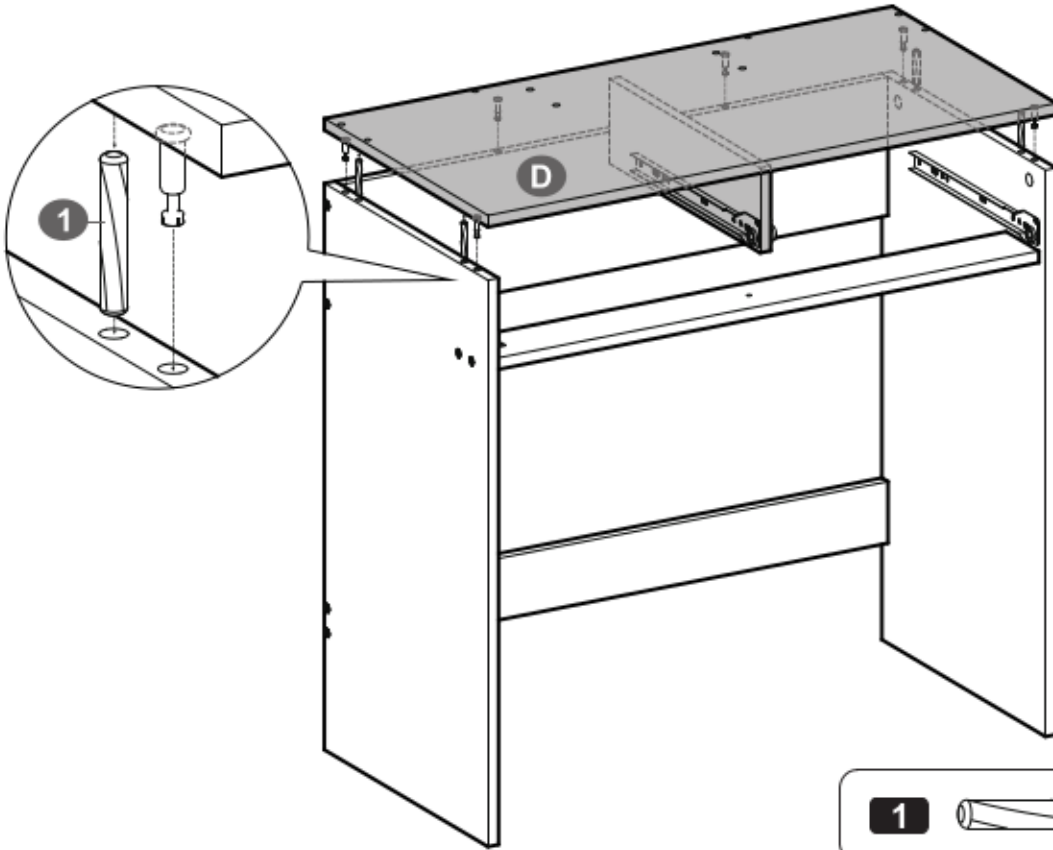

1  × 4

9

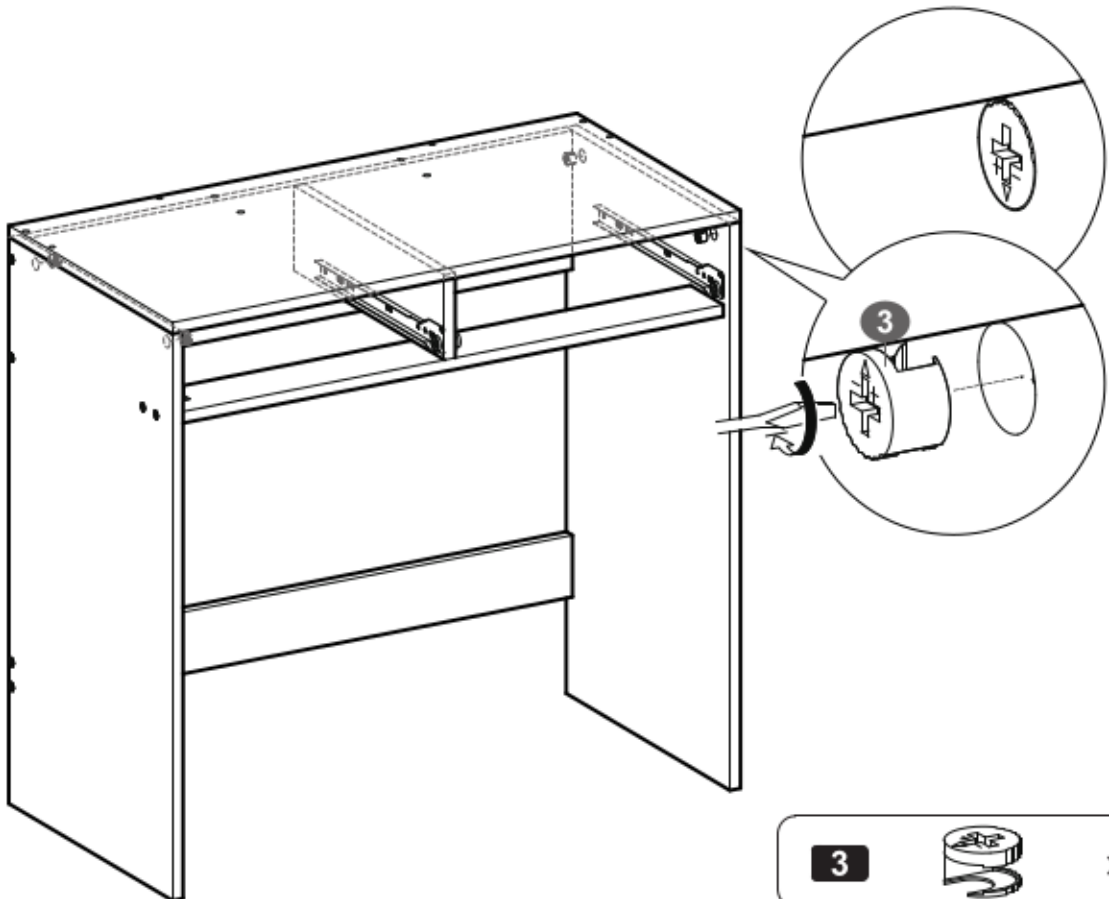

3  × 4

10

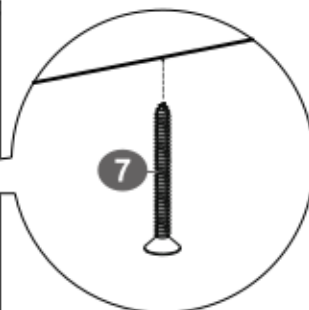
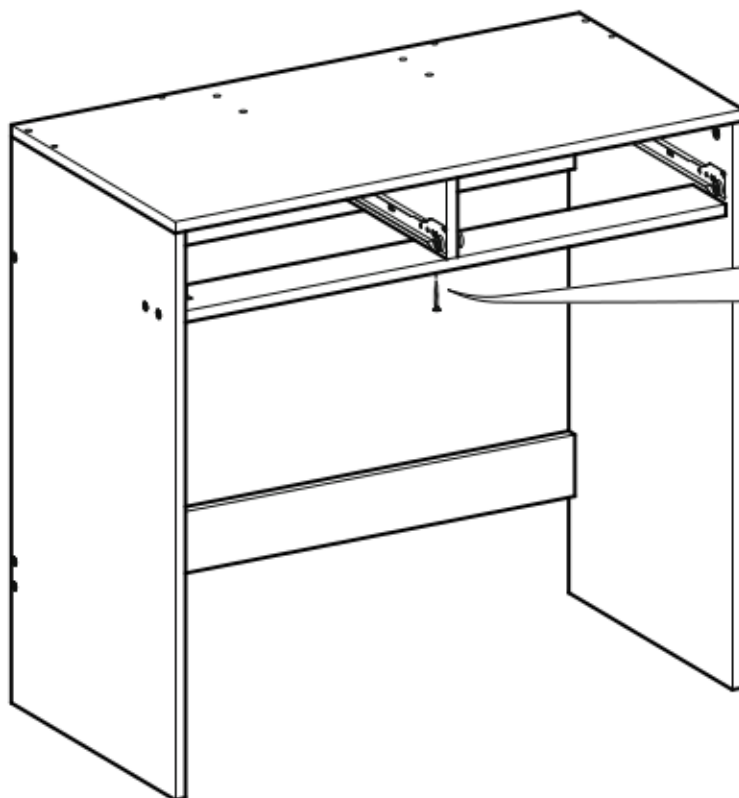

7  × 1

11

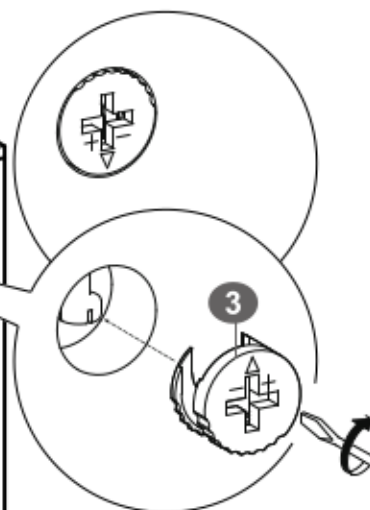
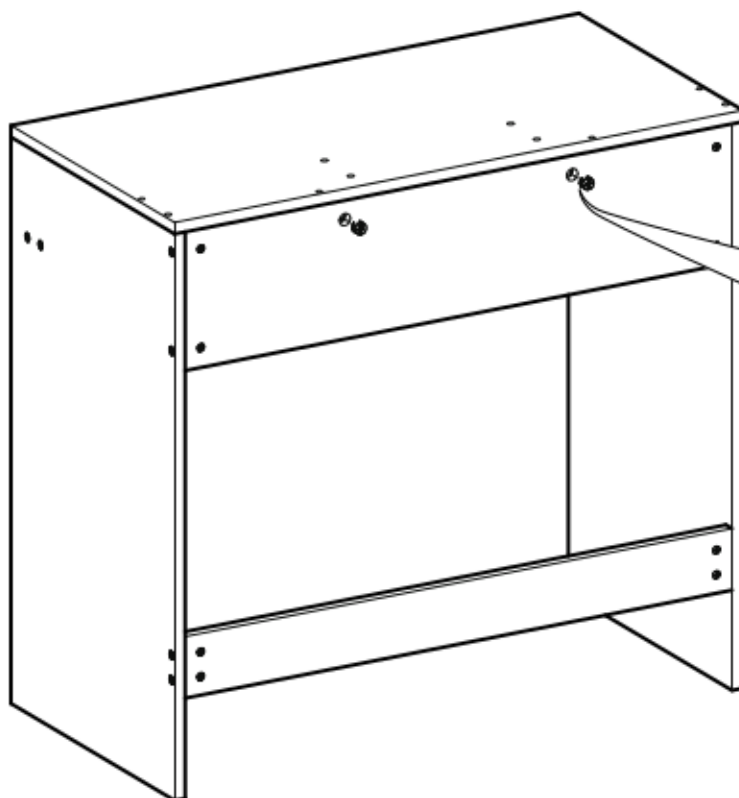

3  × 2

12

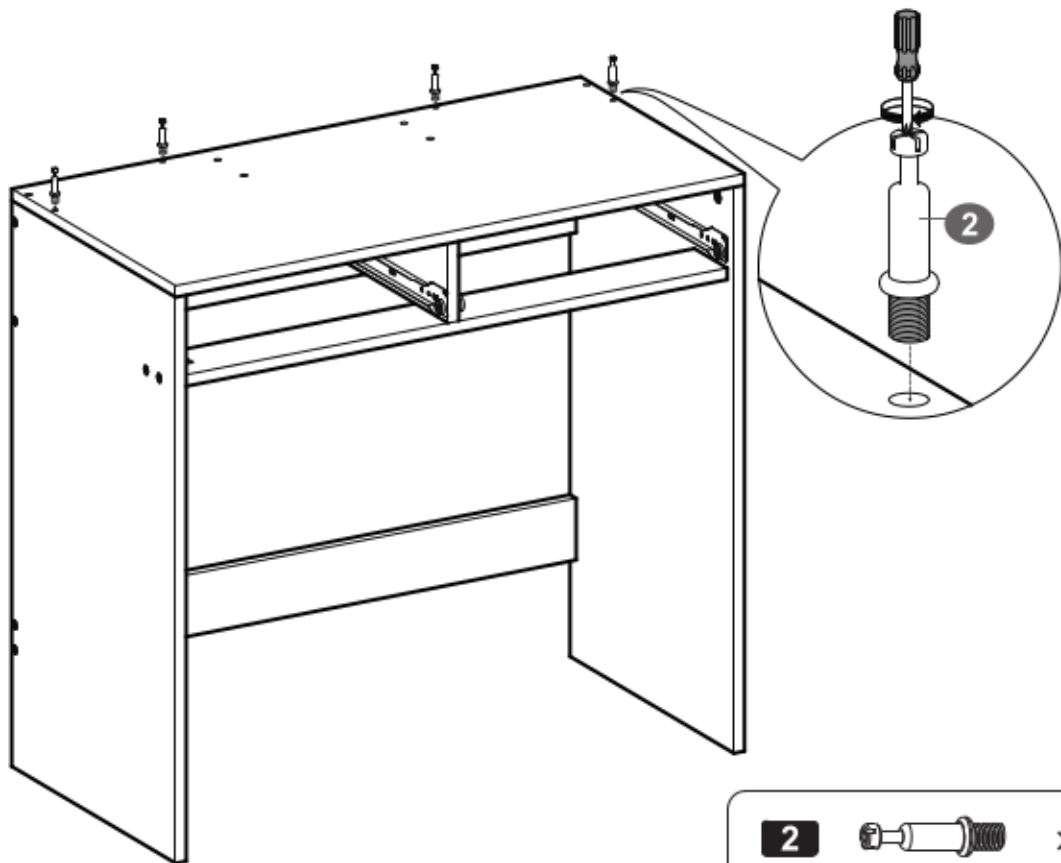

13

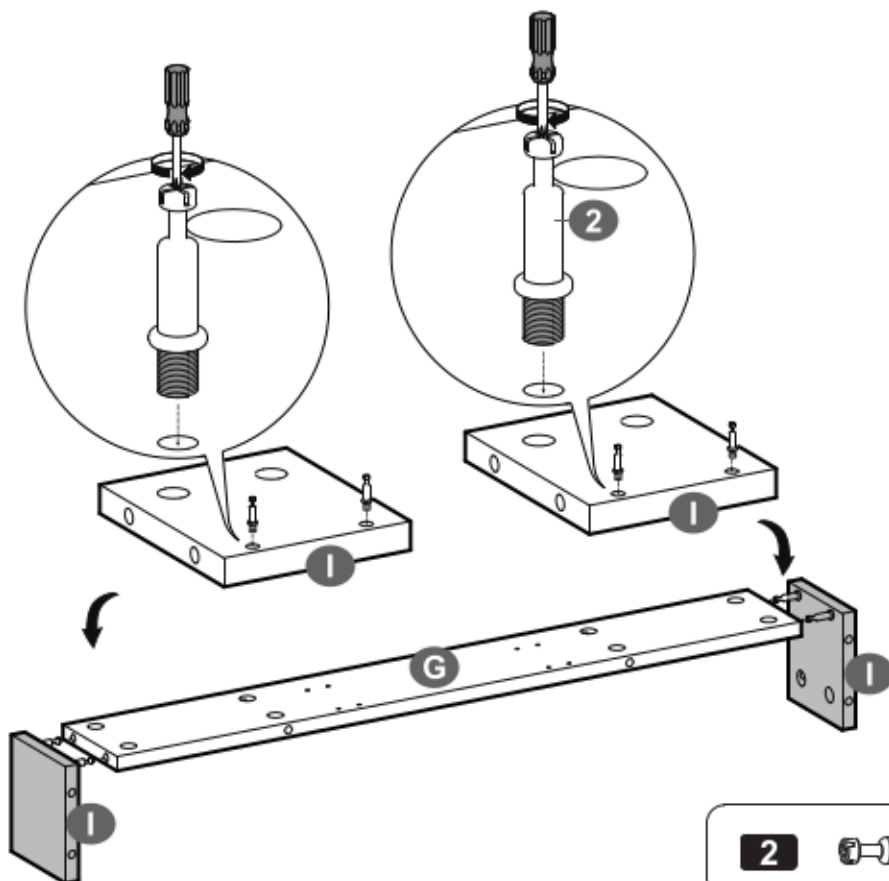

14

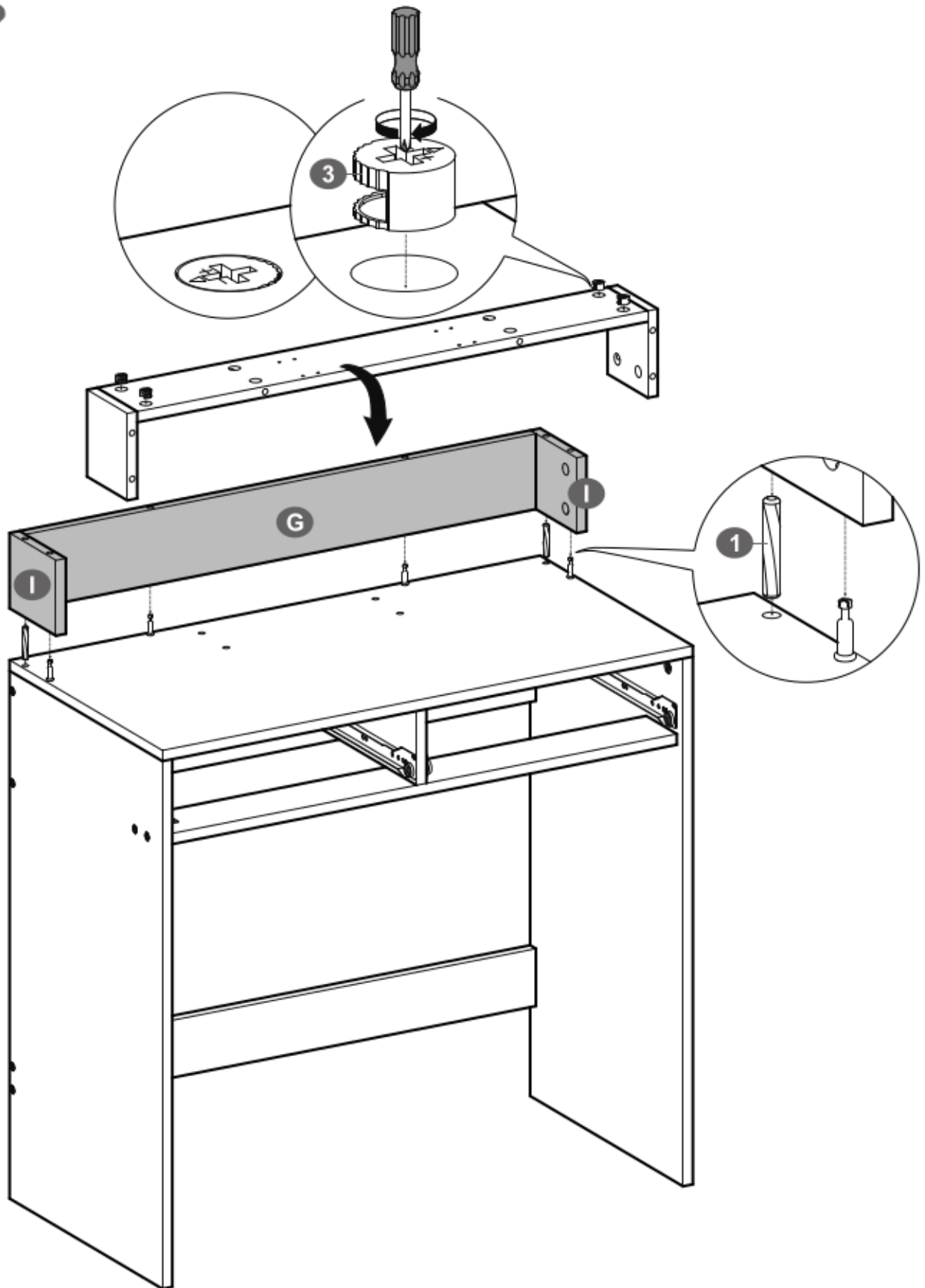

1  × 2

3  × 4

15

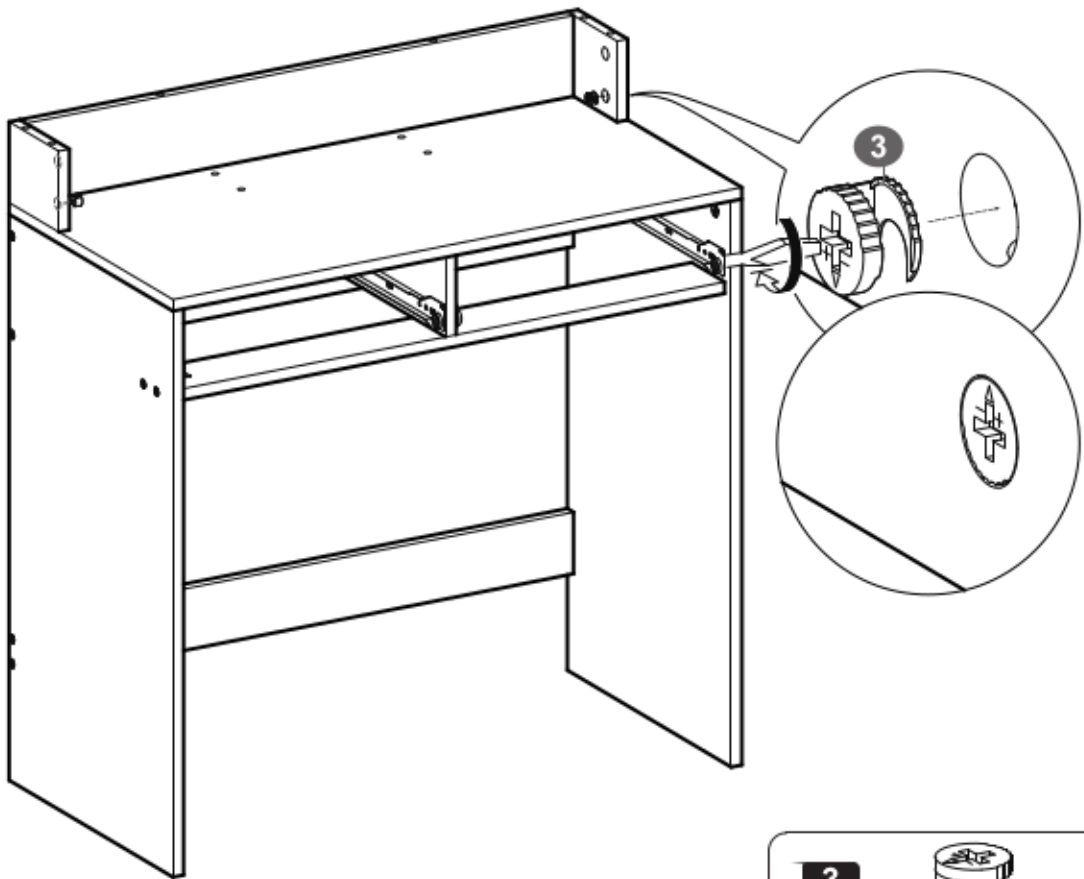

16

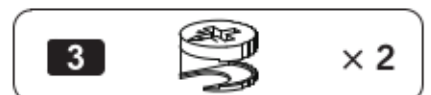
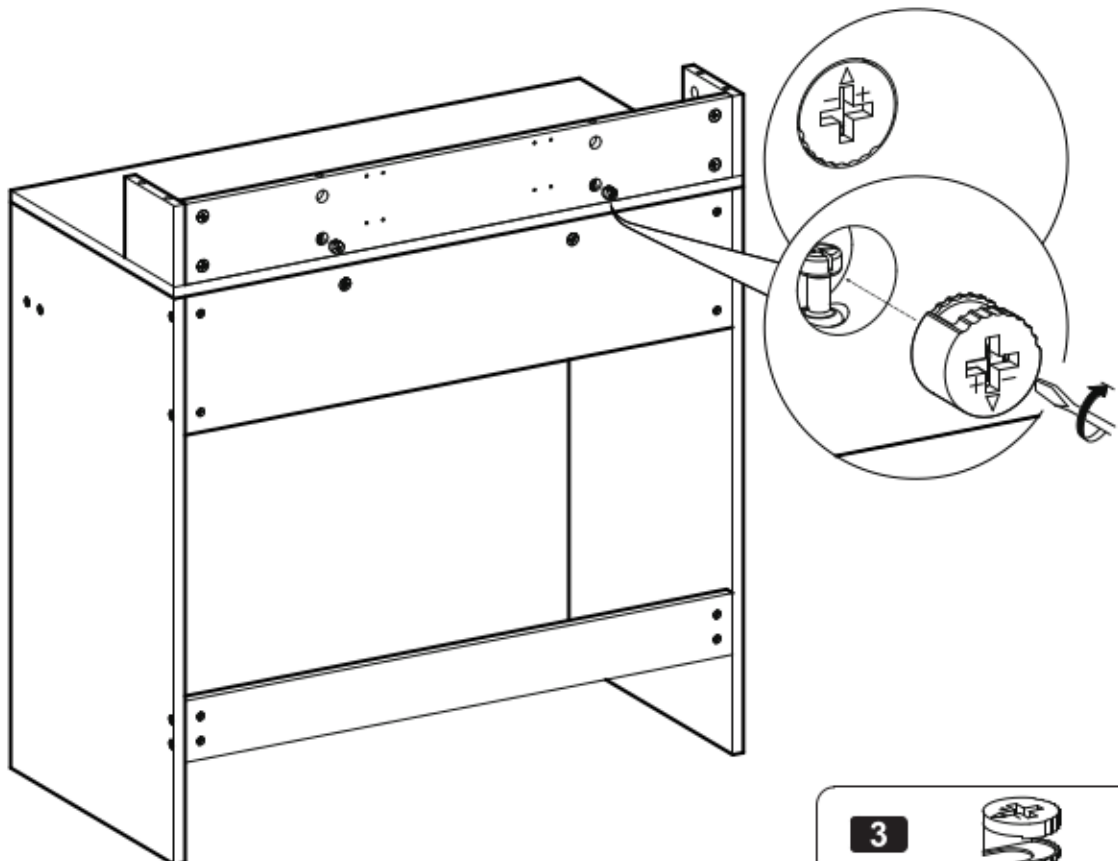

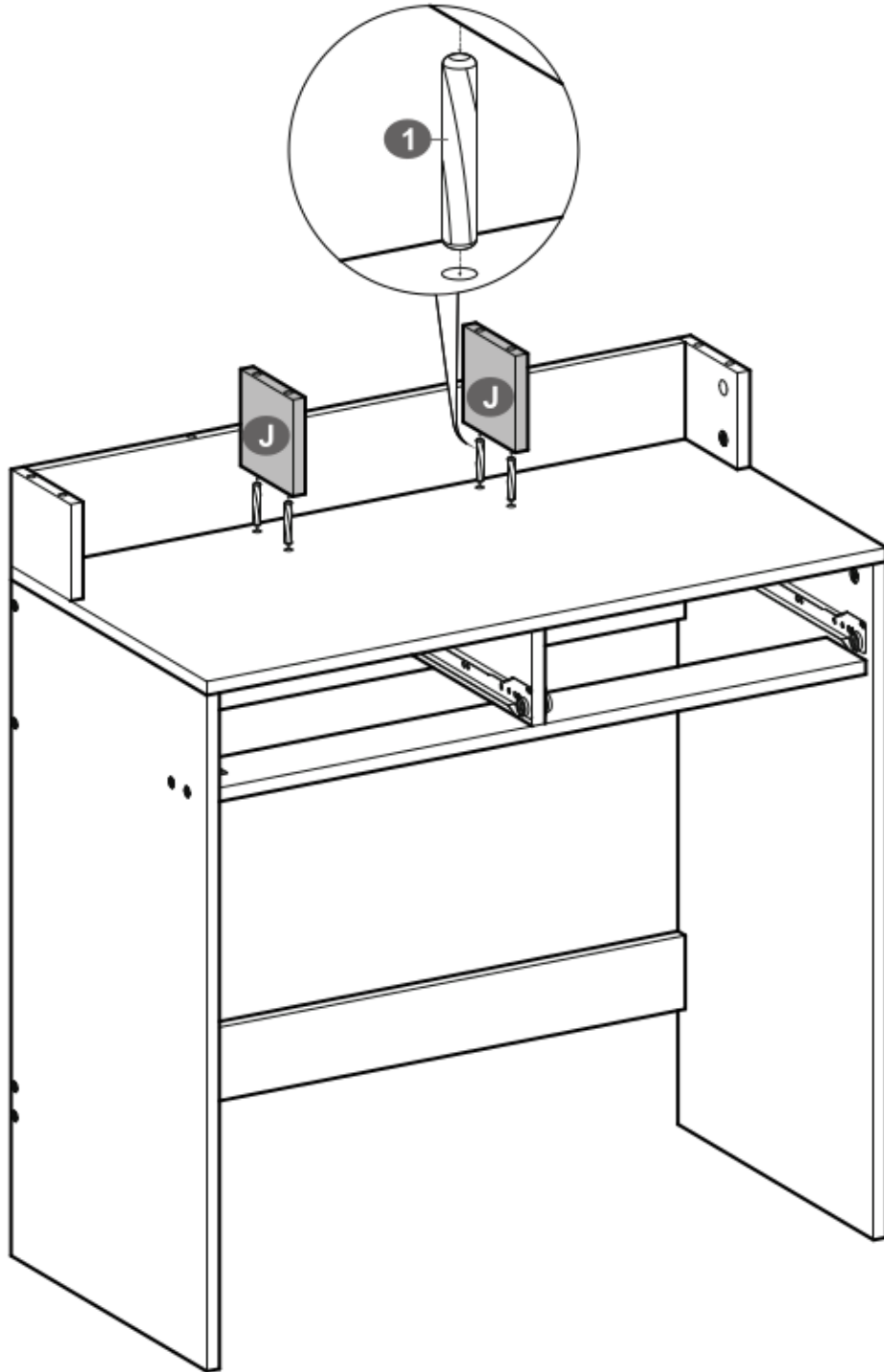

17

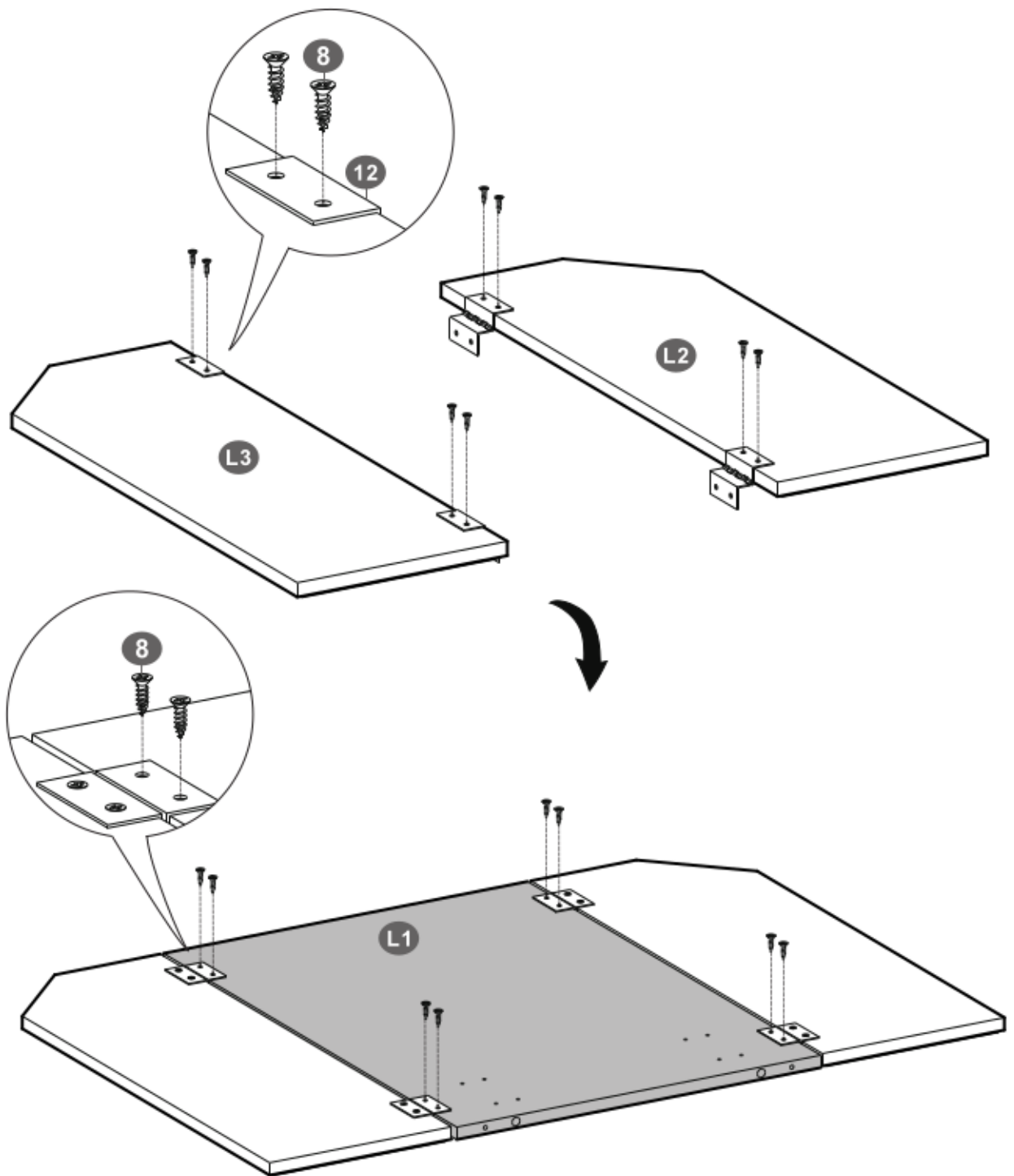

1  × 4

18



8		× 16	12		× 4
----------	---	-------------	-----------	---	------------

19

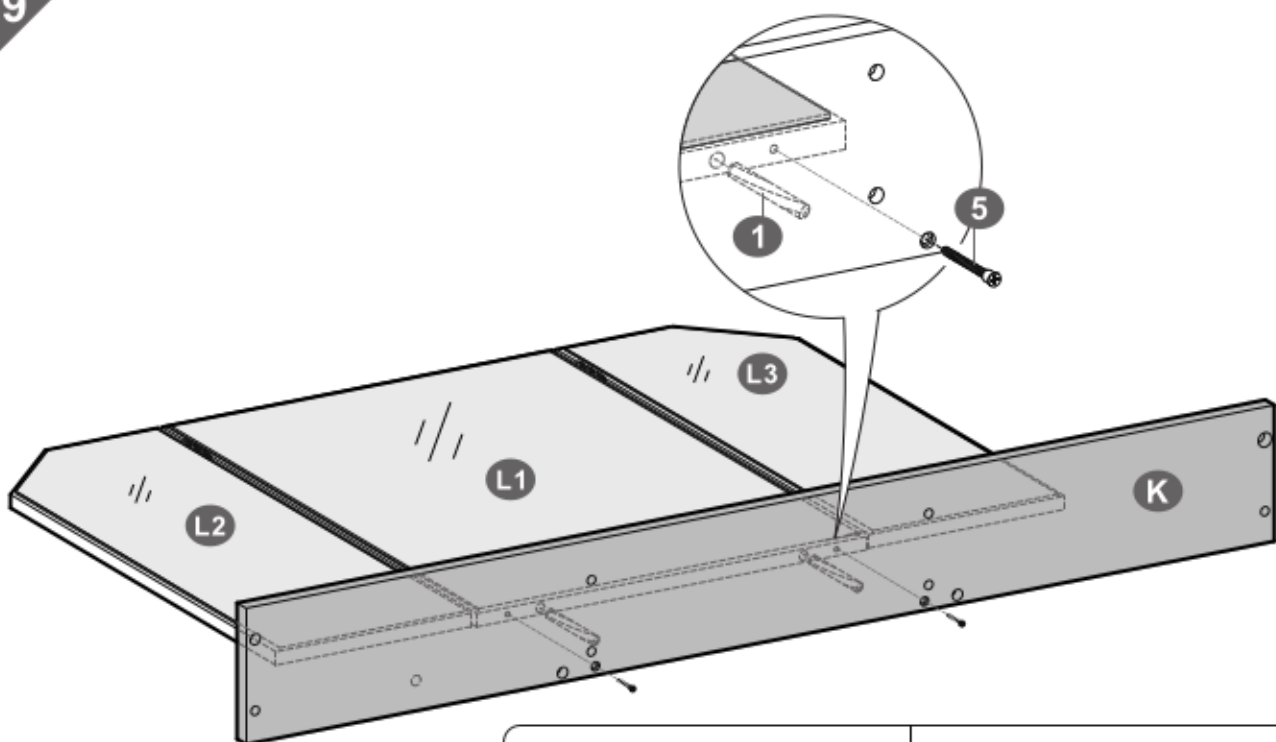

- | | |
|--|--|
| 1  × 2 | 5  × 2 |
|--|--|

20

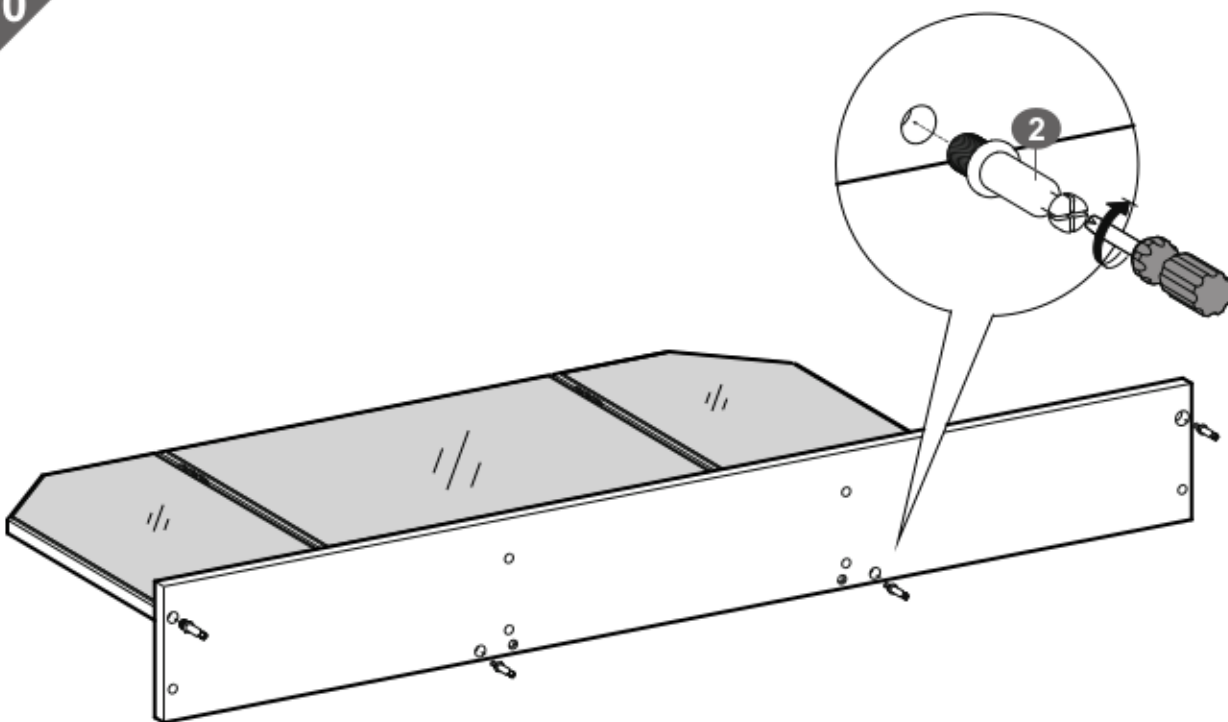

- | |
|--|
| 2  × 4 |
|--|

21

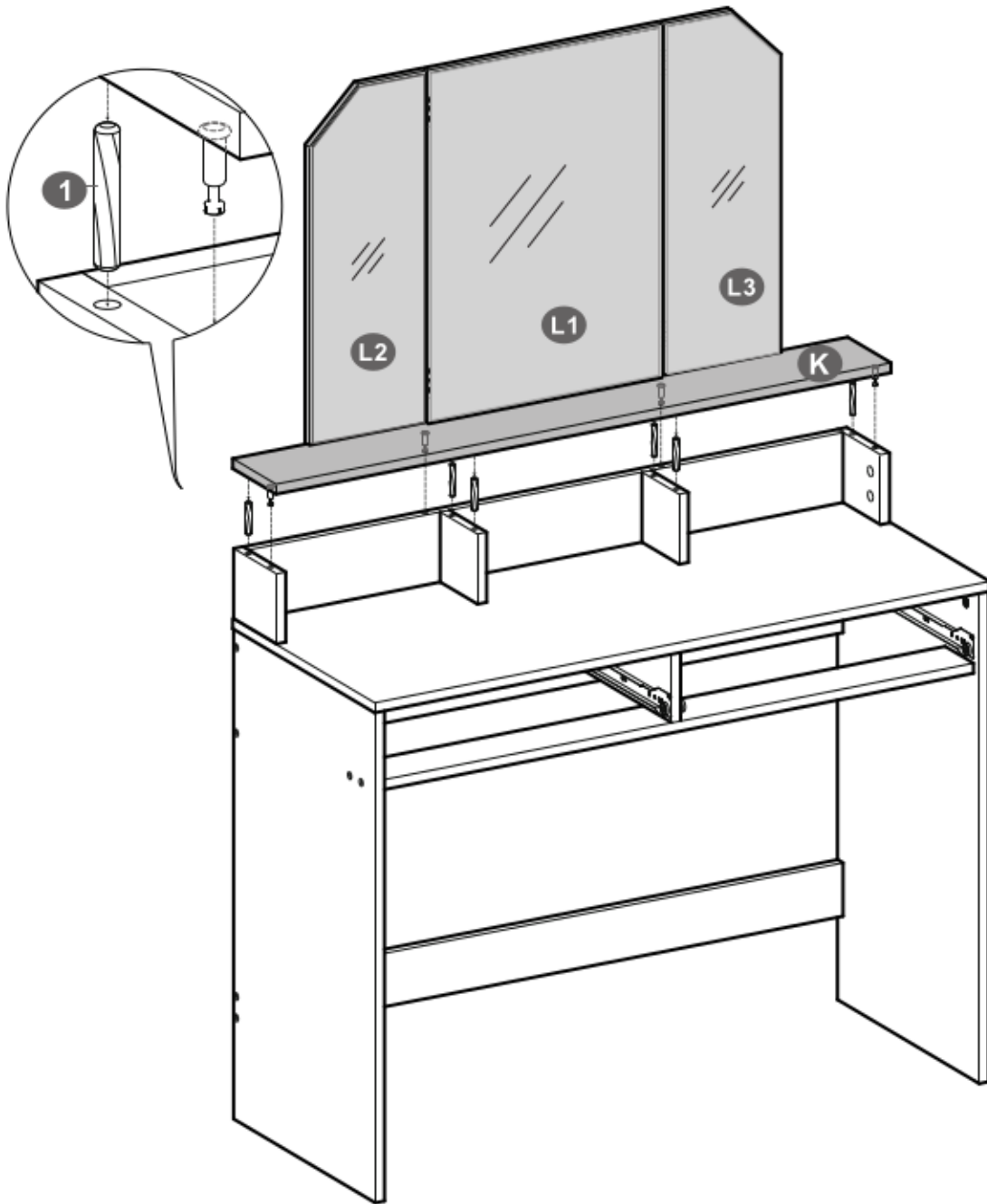

1  × 6

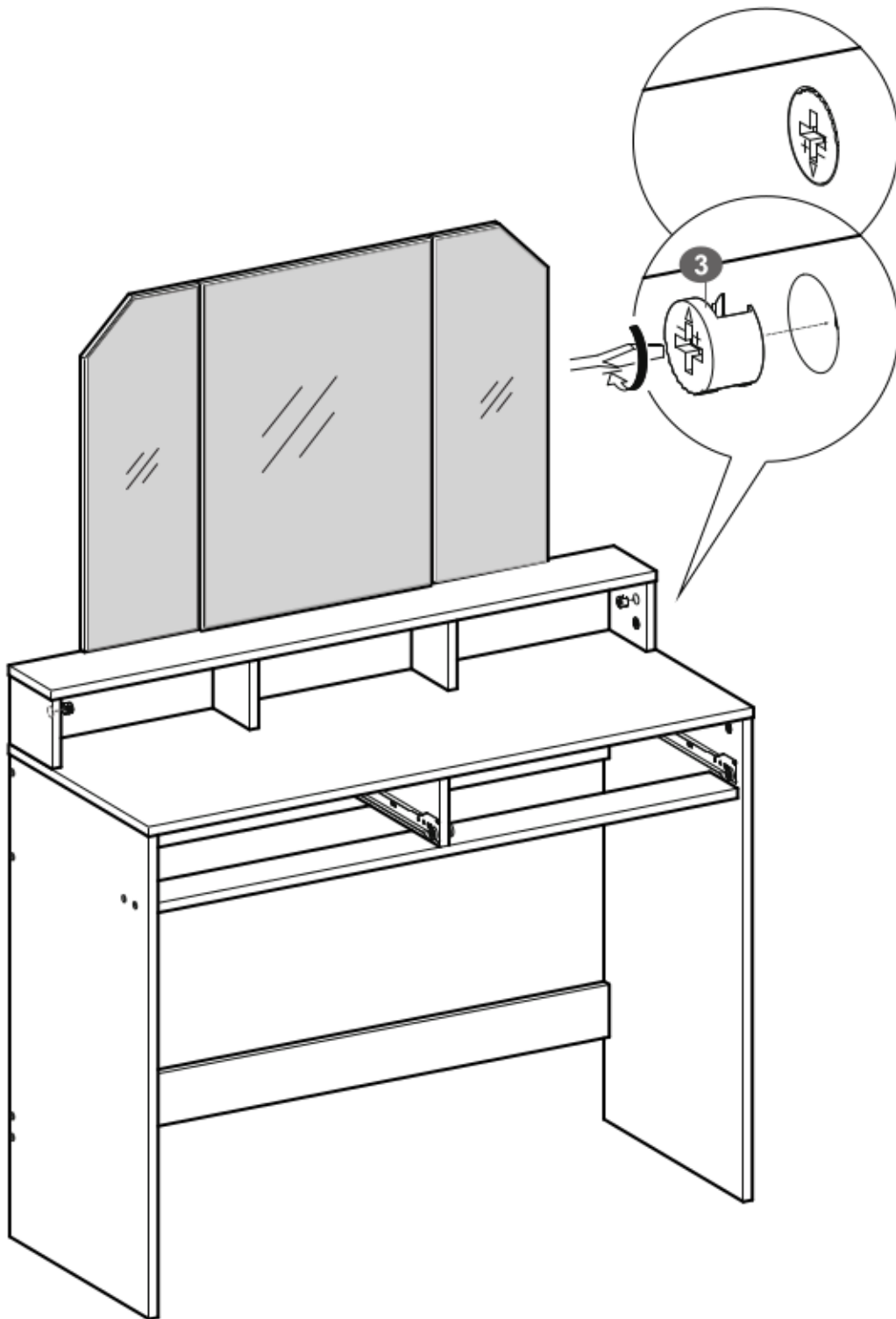

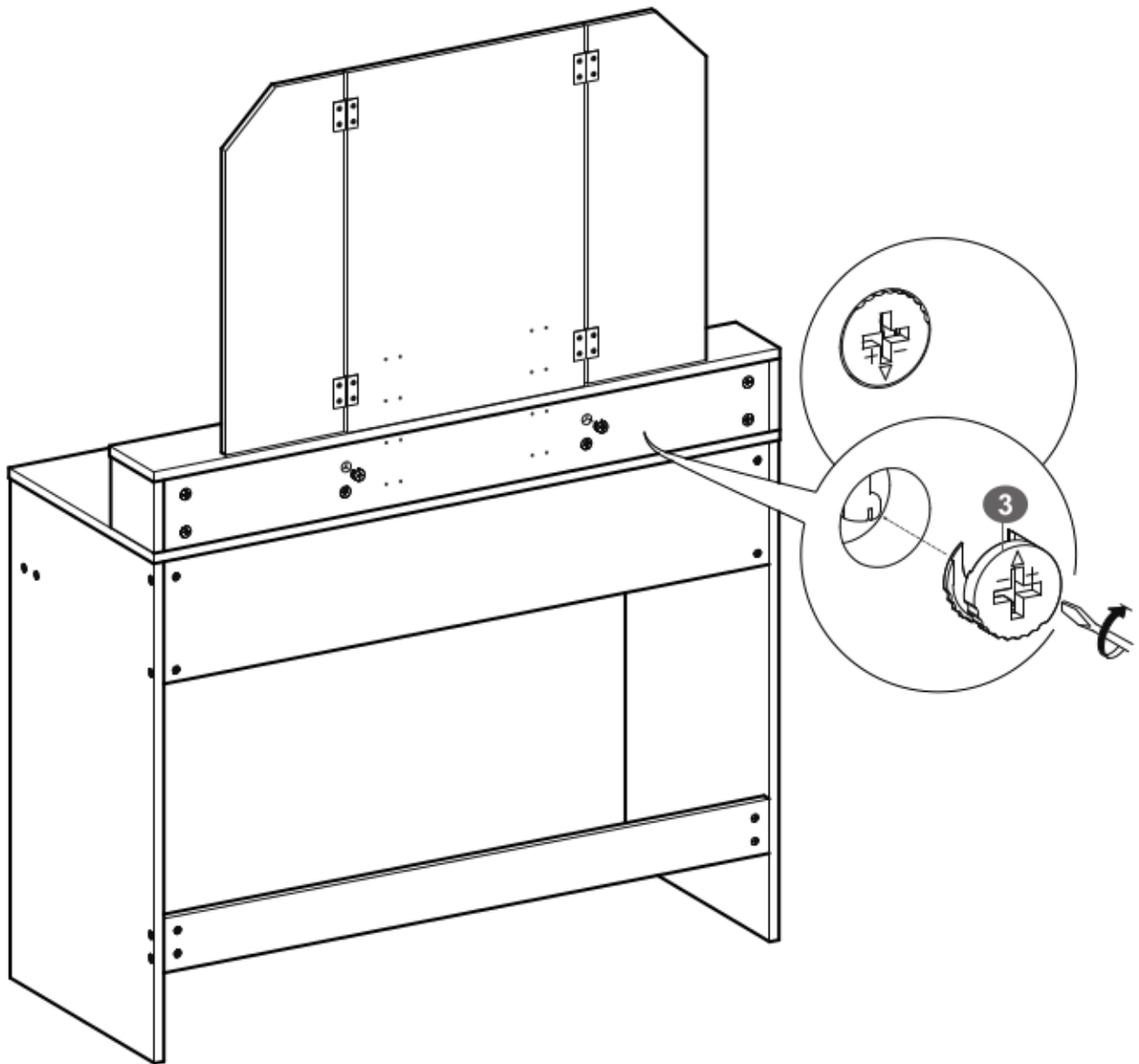

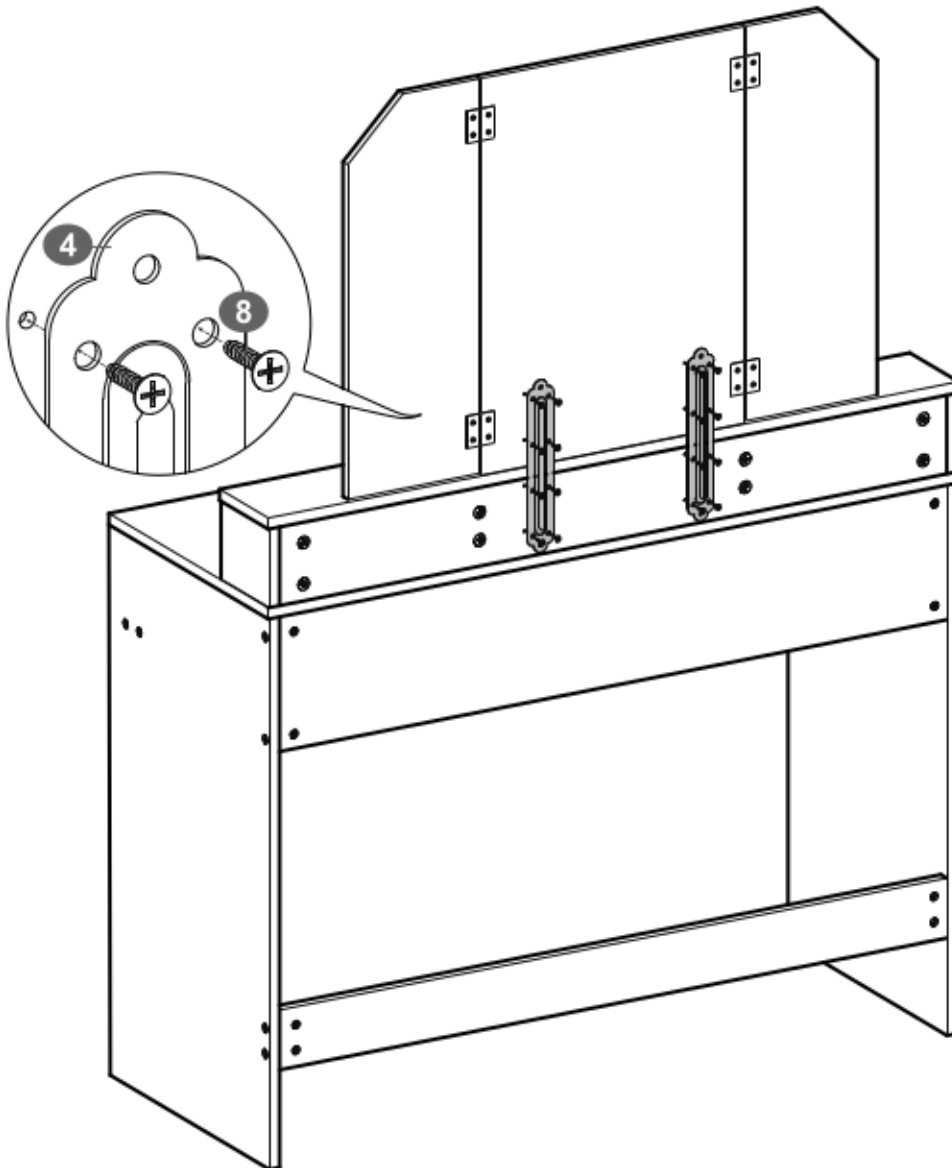

8

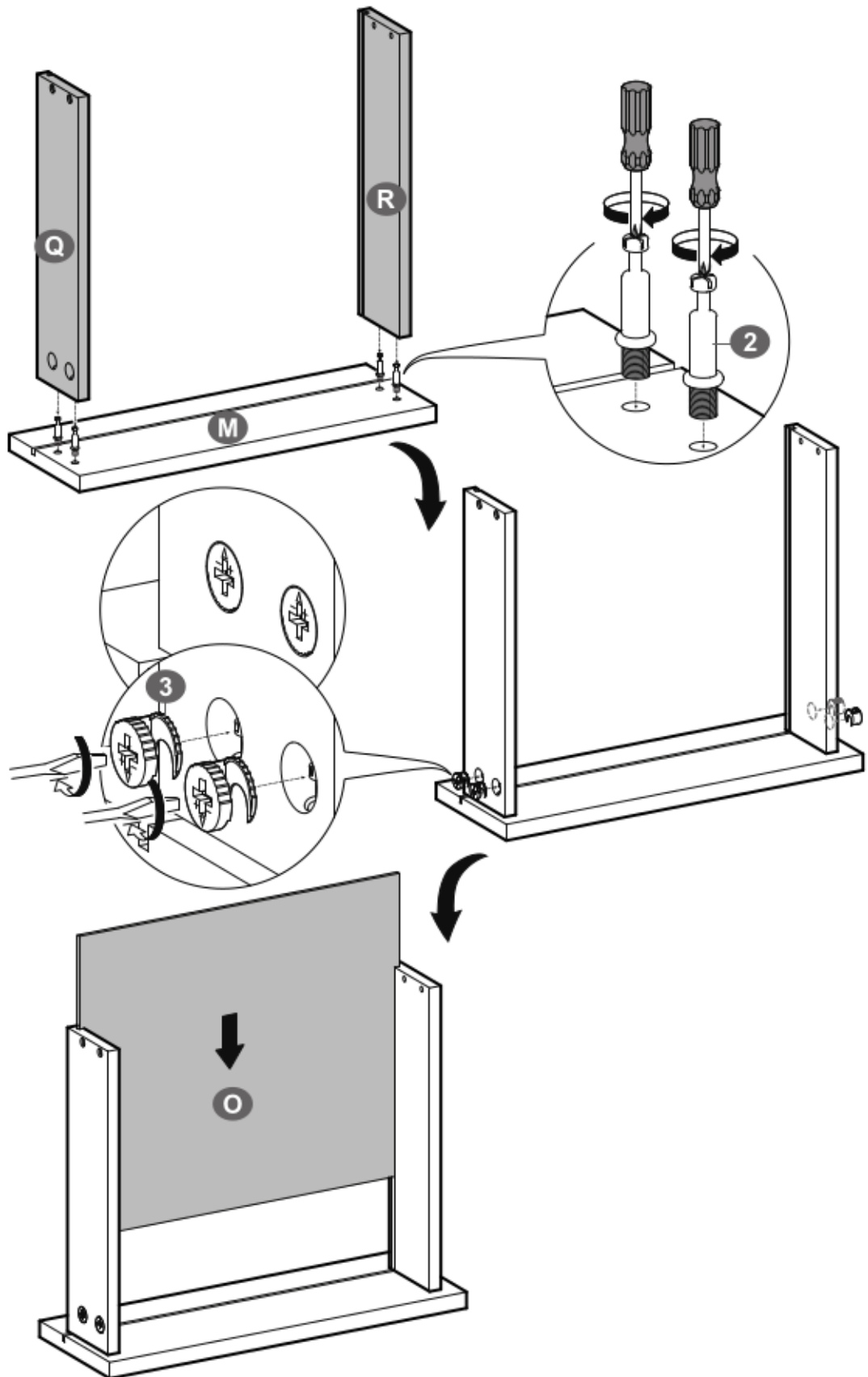
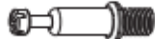

× 16

**2**

× 4

3

× 4

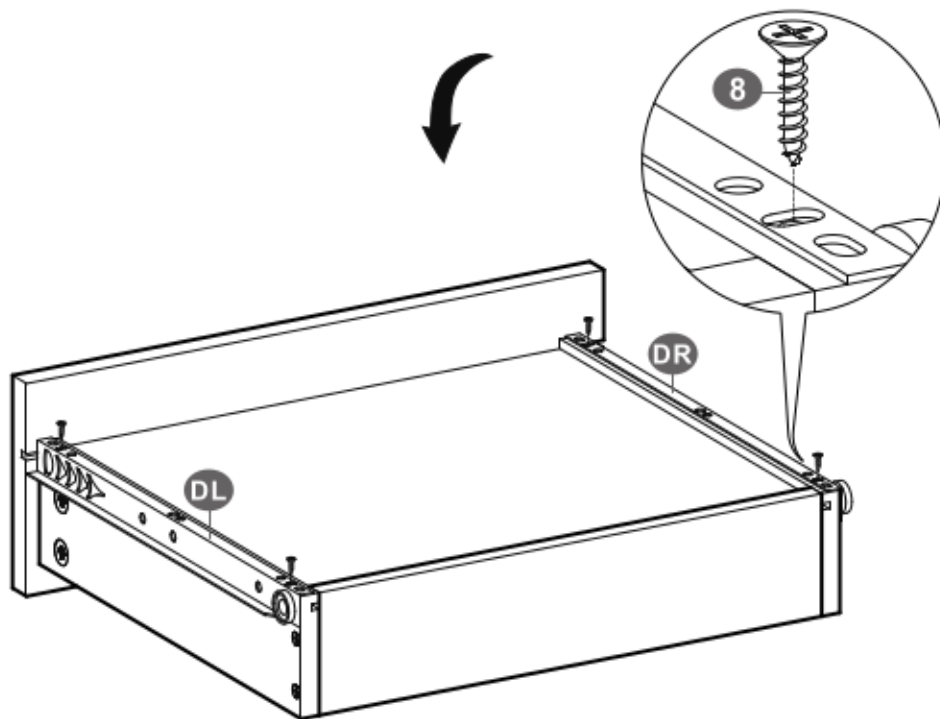
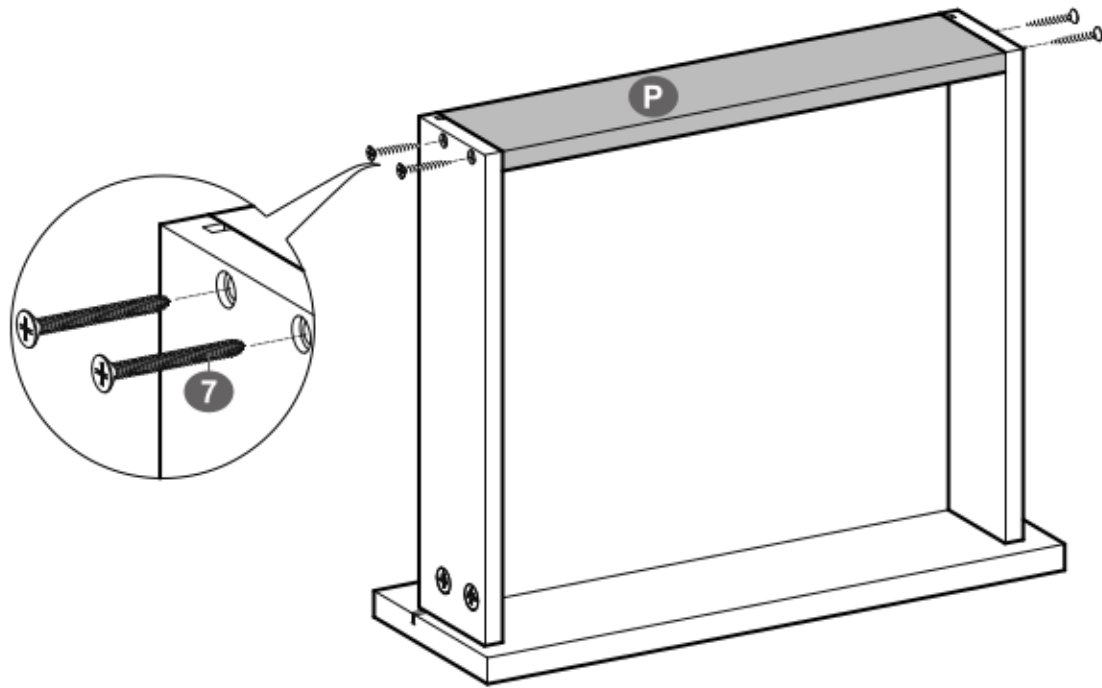

7  × 4

8  × 4

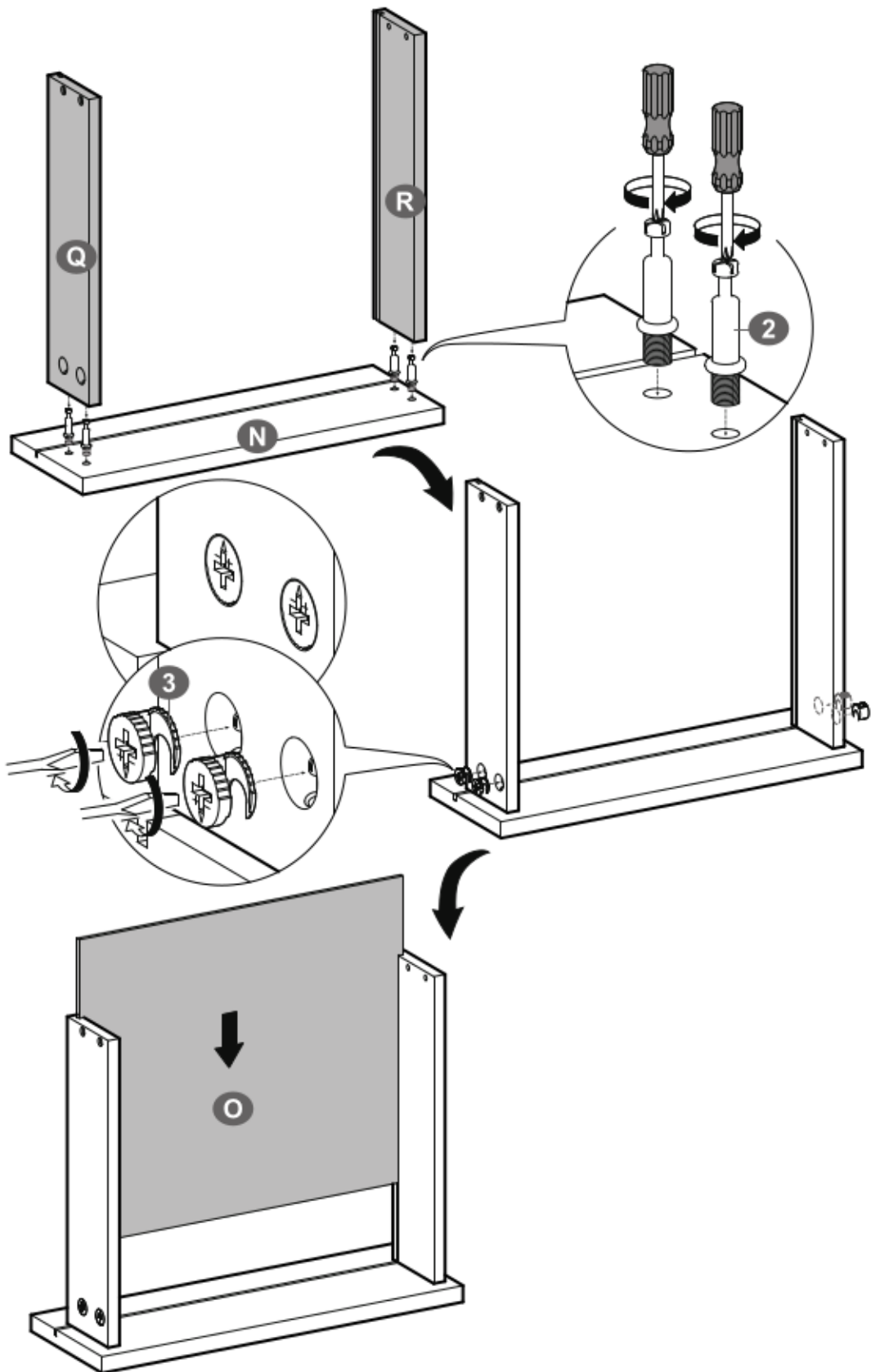

2

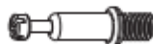

× 4

3



× 4

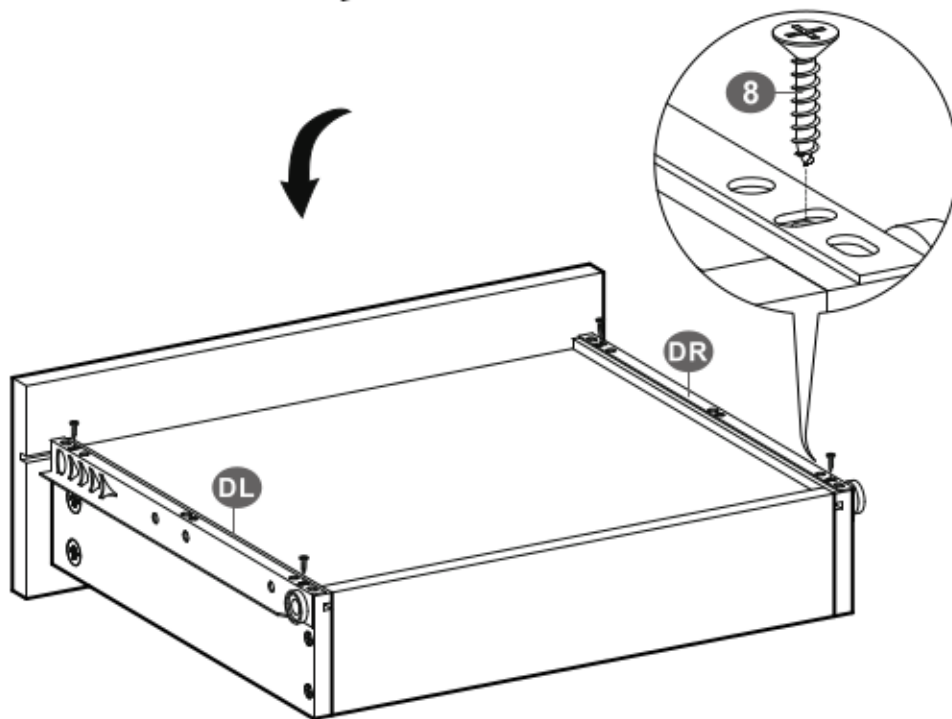
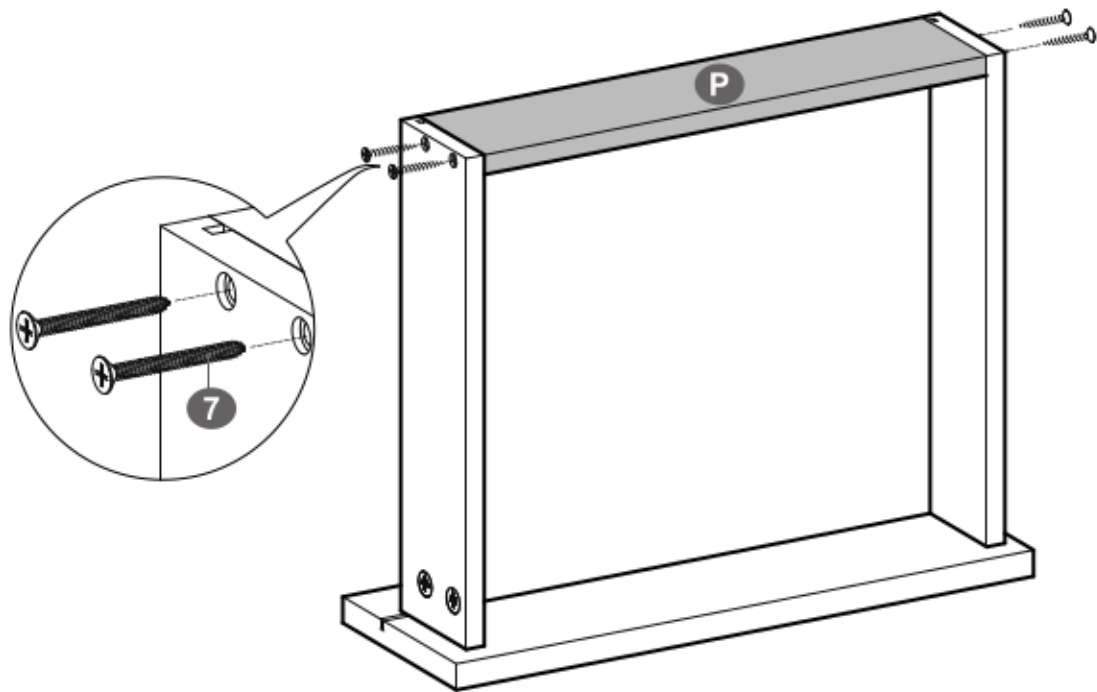

7  × 4

8  × 4

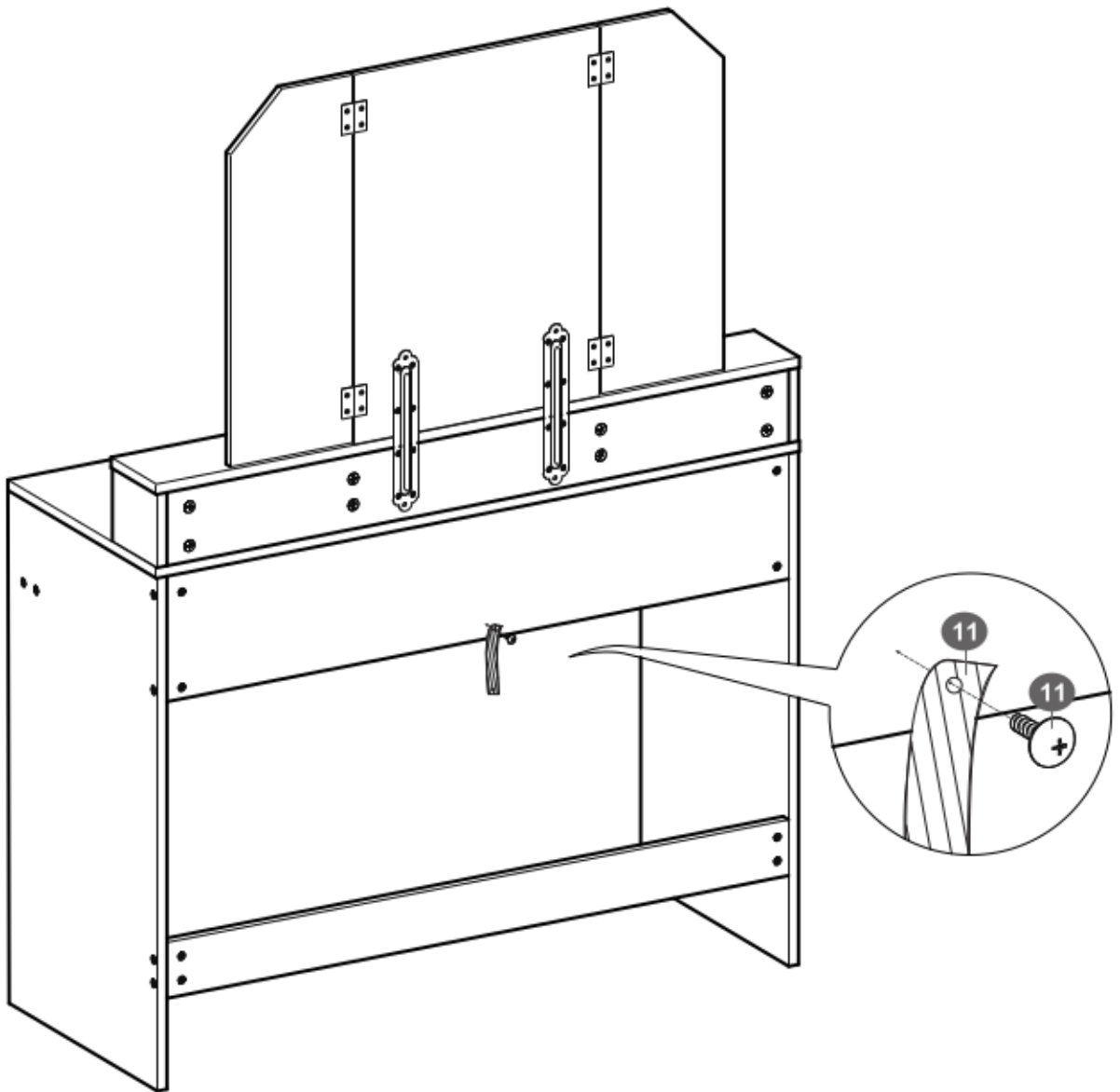

11

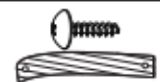

× 1

