

1 → 2 → 3 ...

1

8x Nr.98	4x Nr.367	1x Nr.128
-------------	--------------	--------------

4x Nr.502	1x Nr.510	2x Ø8x30 Nr.80
--------------	--------------	----------------------

2

8x Nr.76	16x Ø8x30 Nr.80
-------------	-----------------------

2x Nr.144	2x Nr.143	4x 4x15 Nr.158
--------------	--------------	----------------------

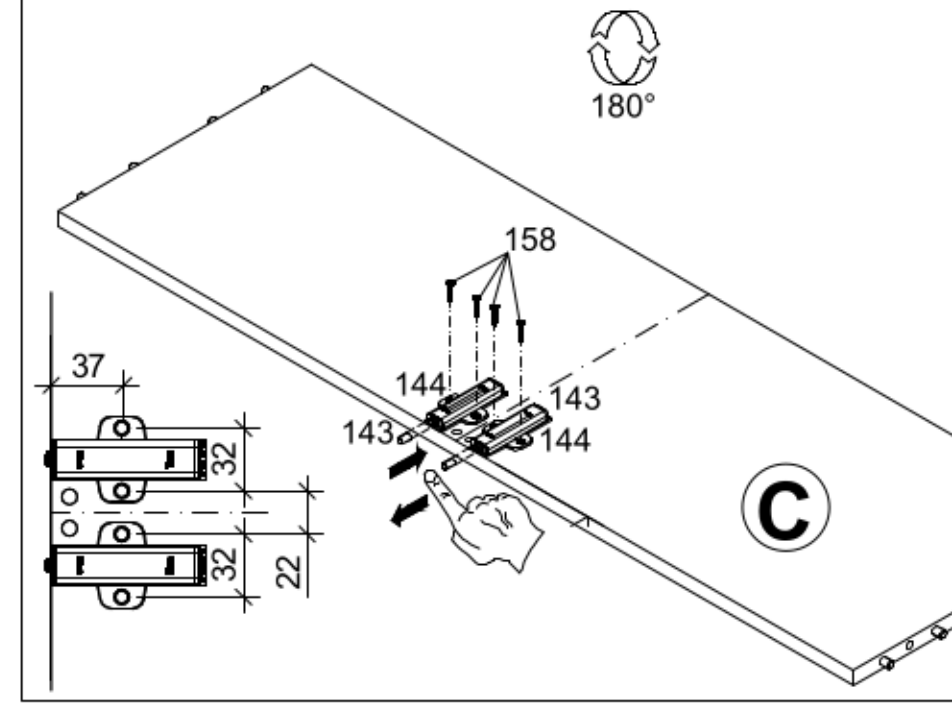
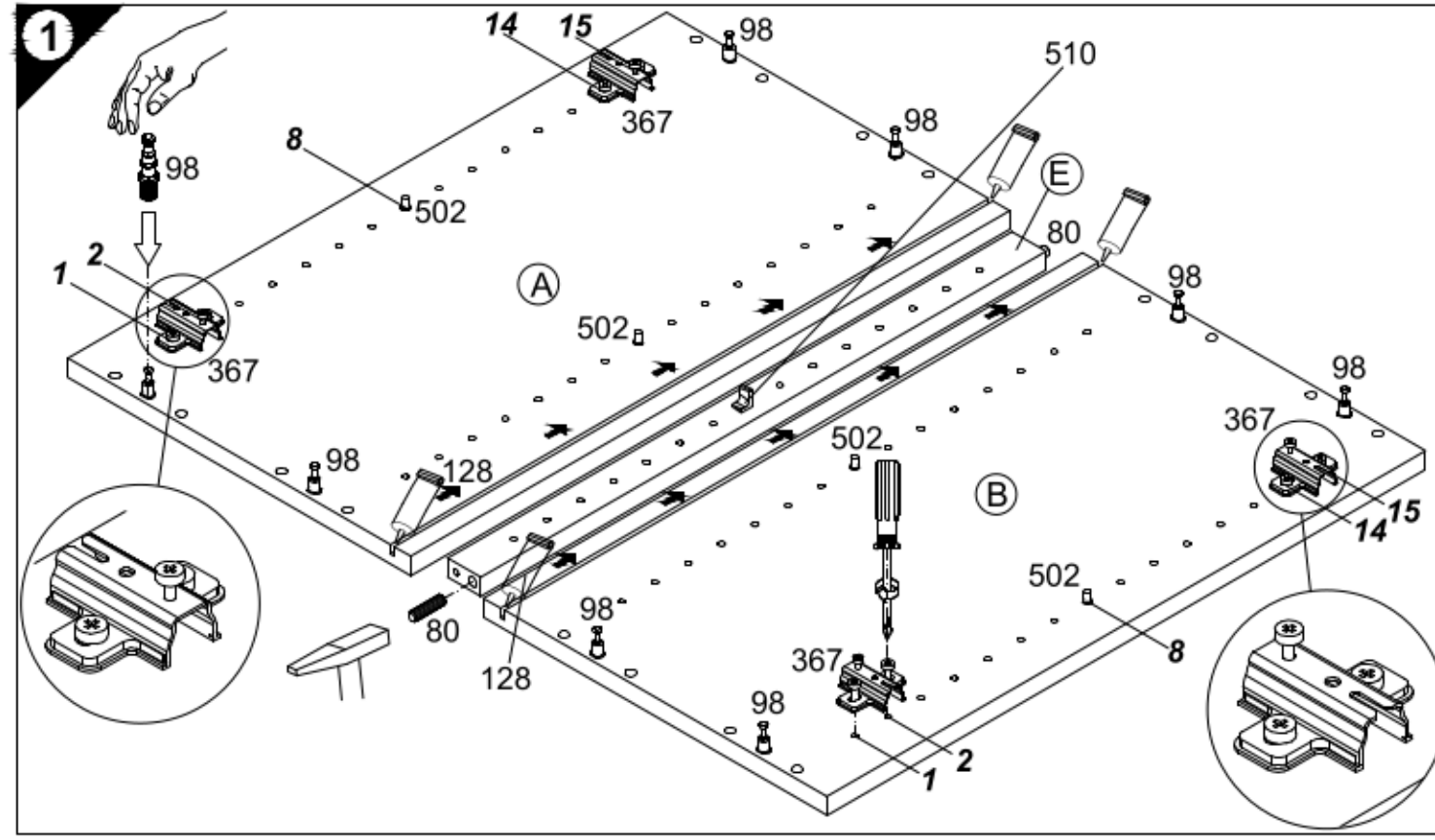
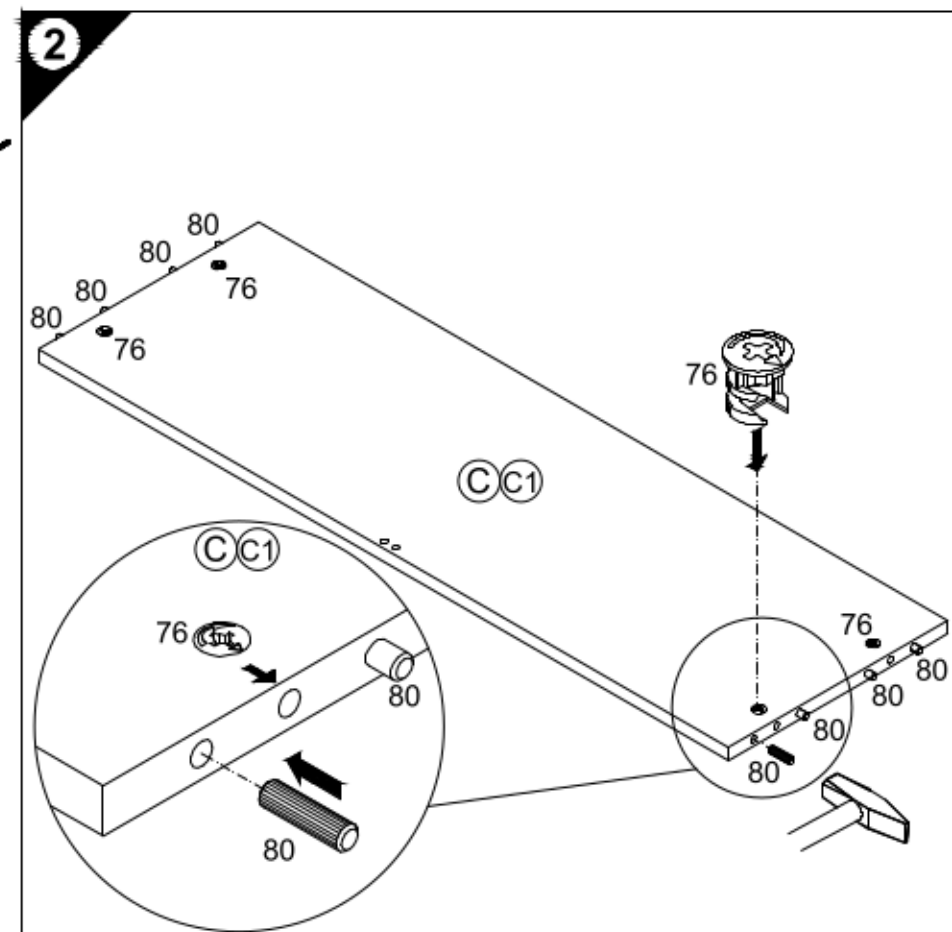
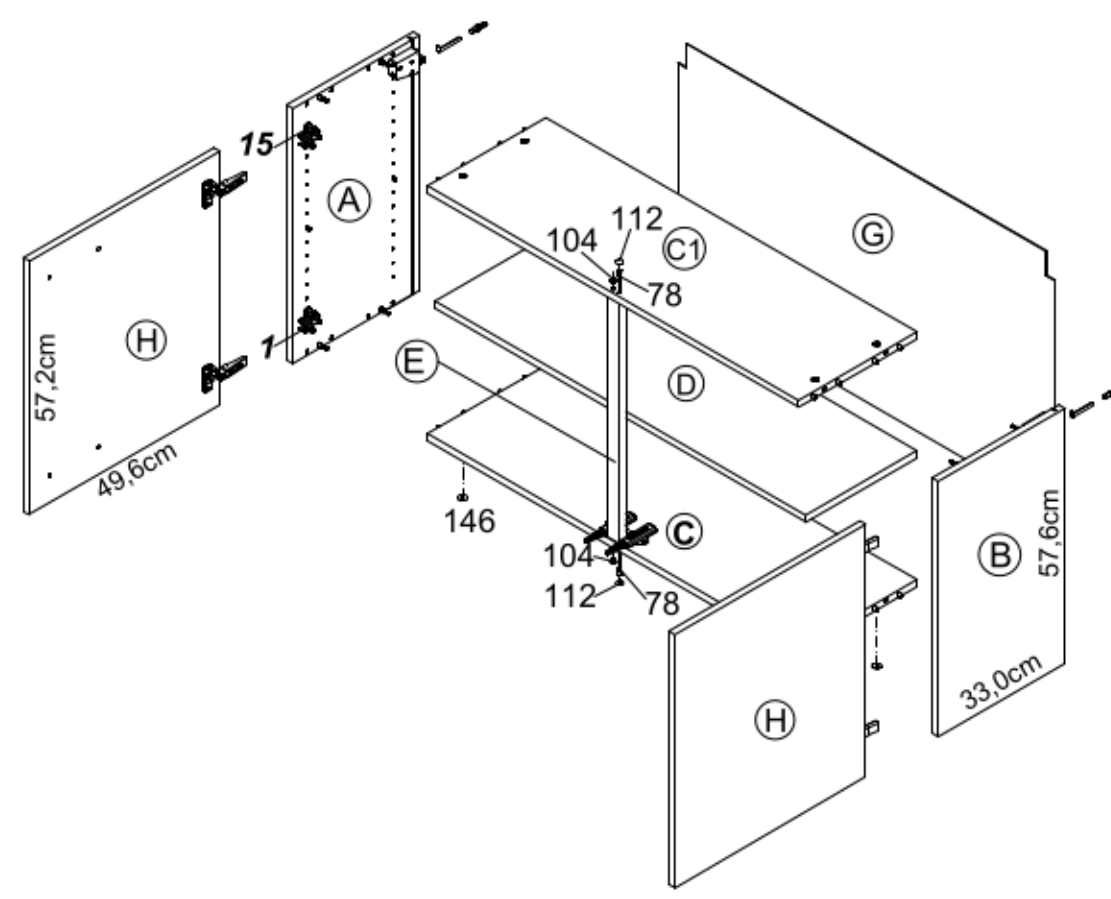
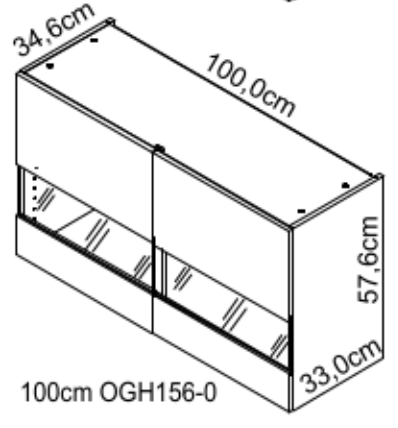
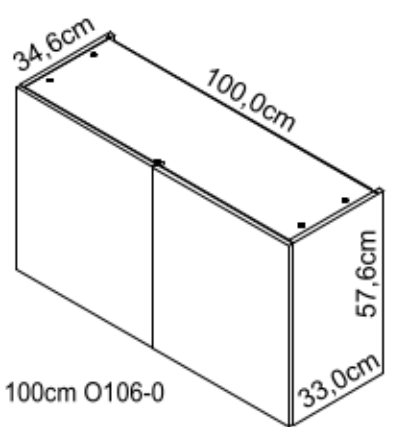

1 → 2 → 3 ...

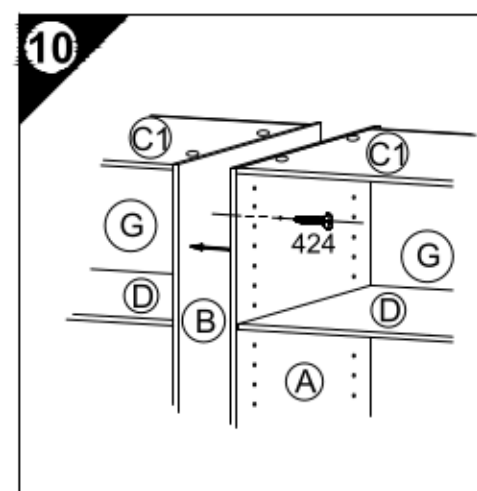
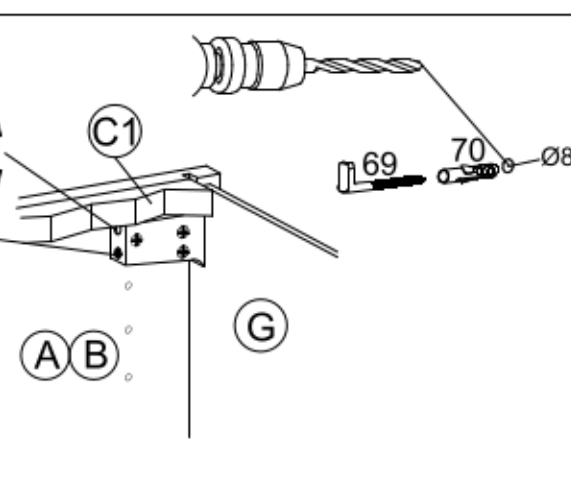
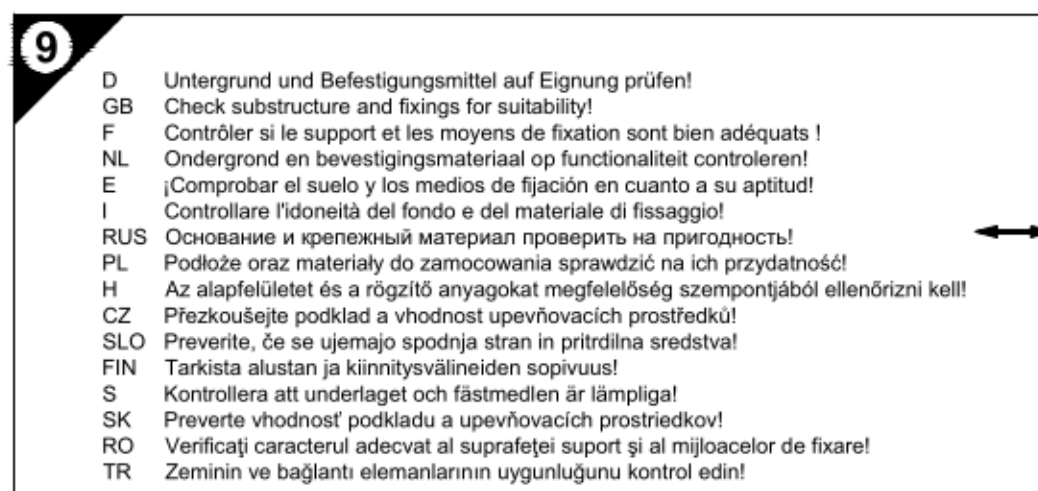
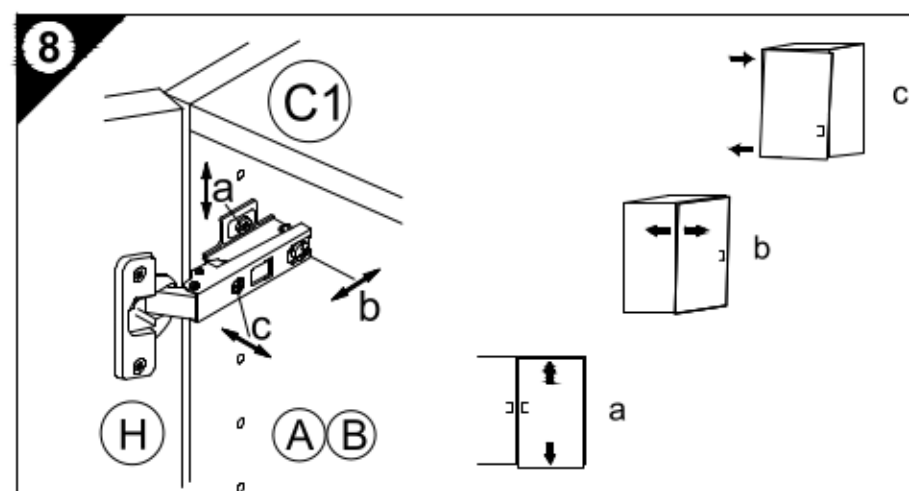
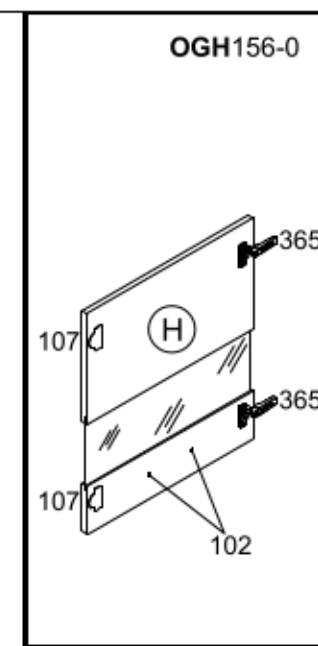
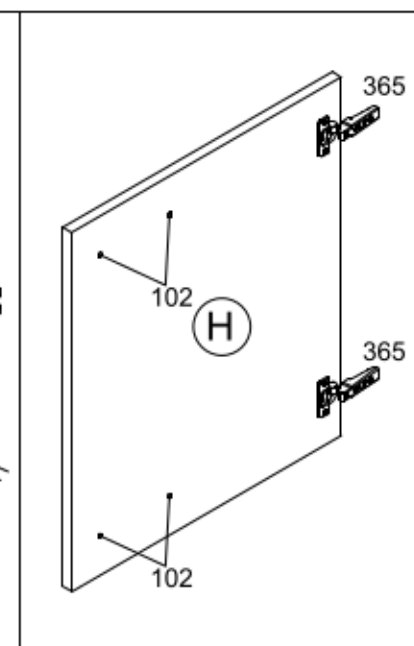
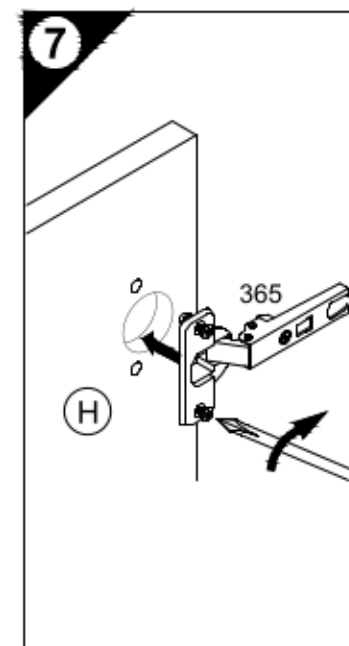
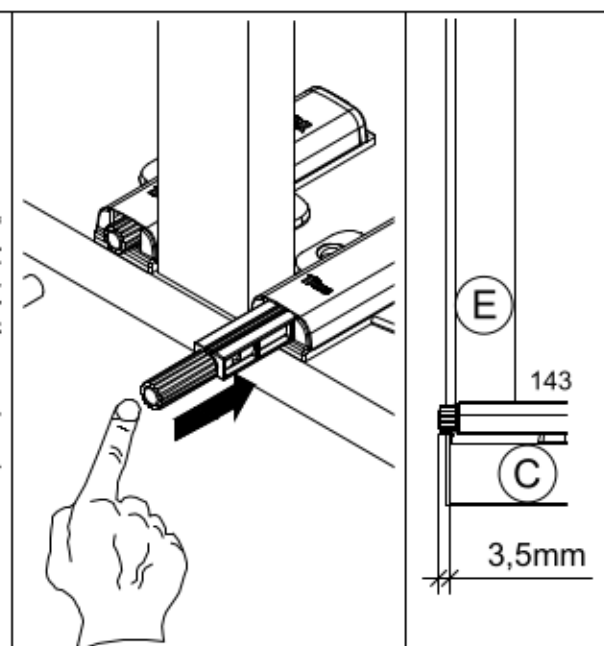
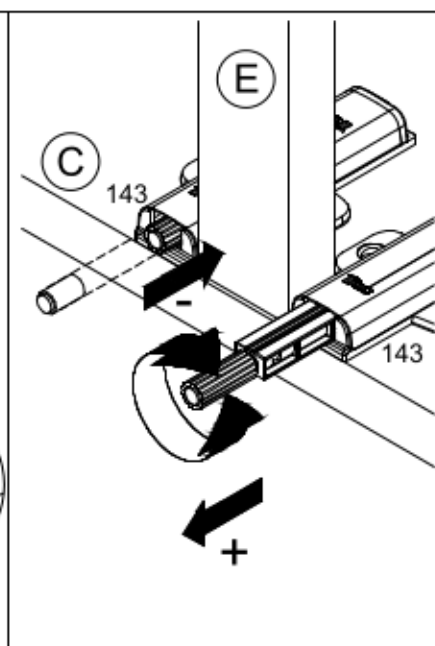
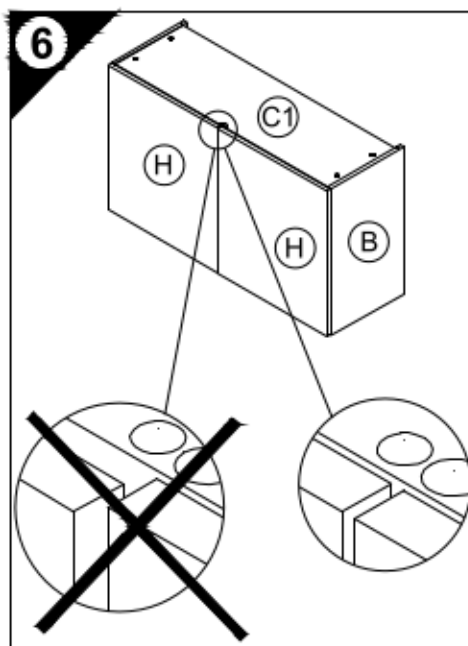
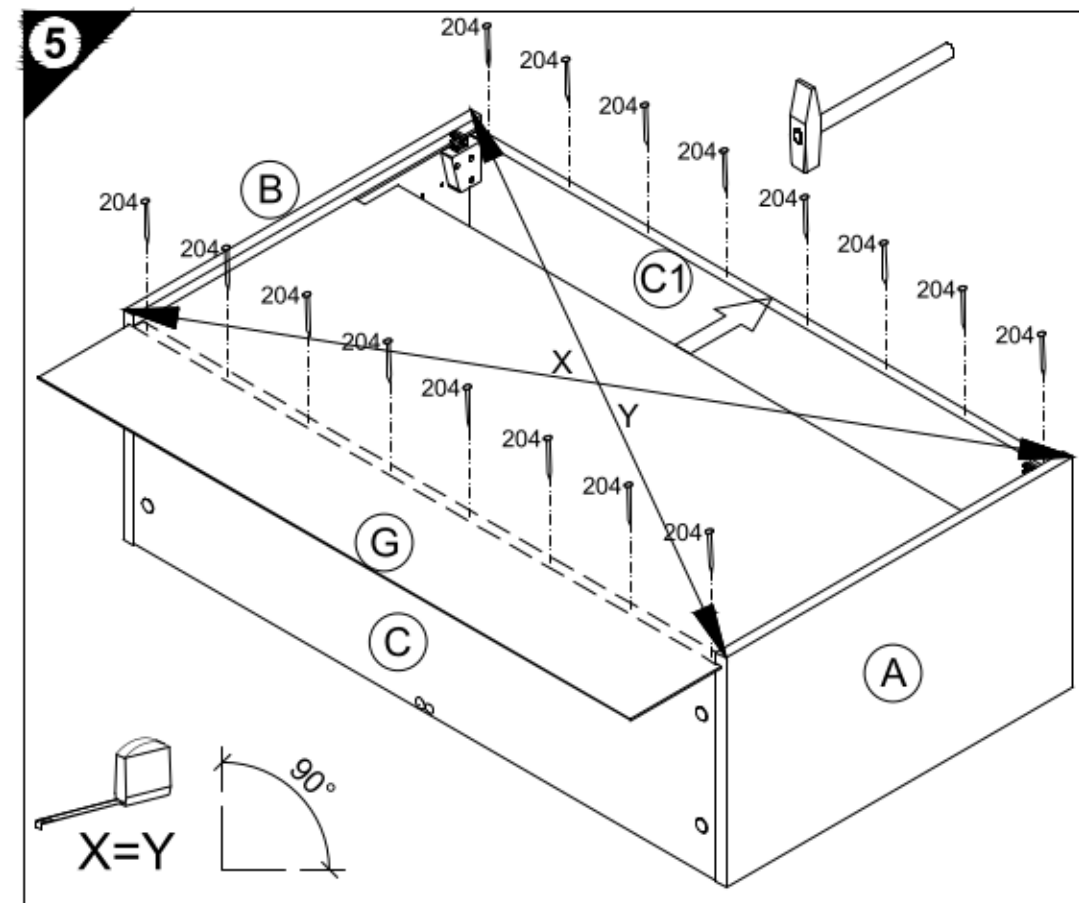
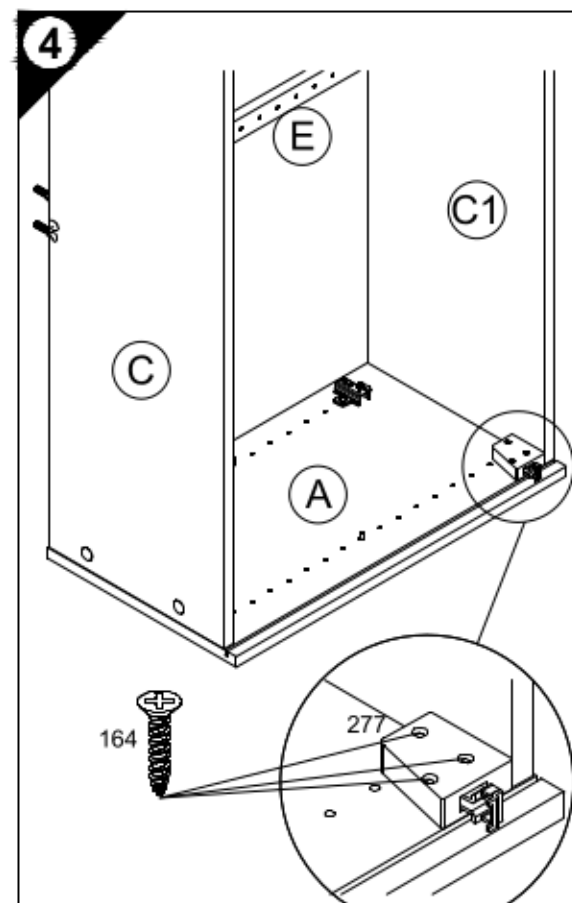
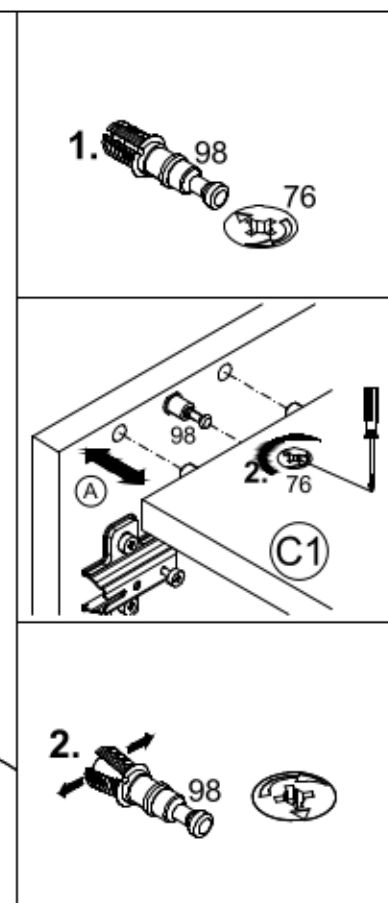
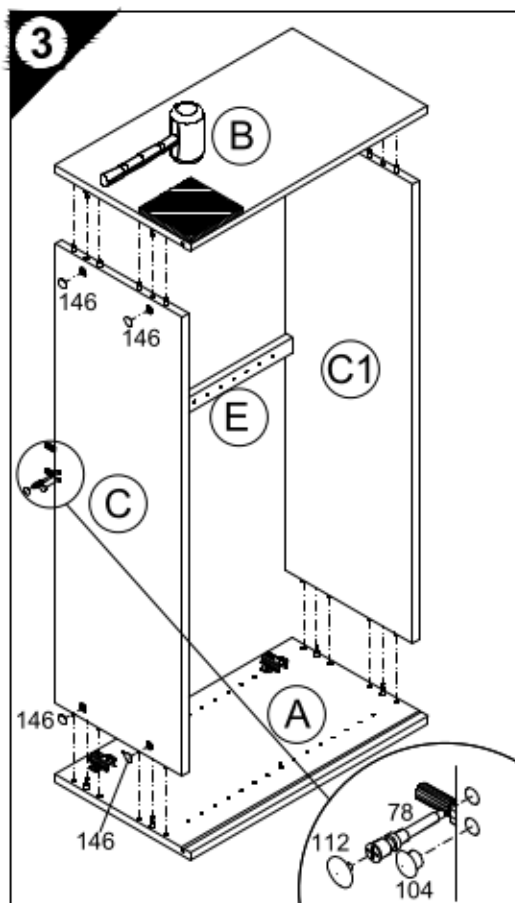
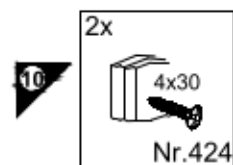
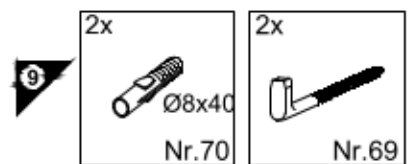
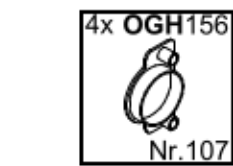
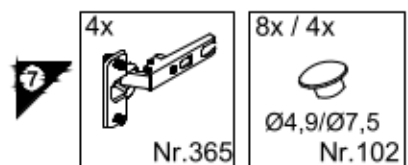
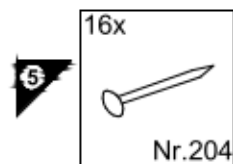
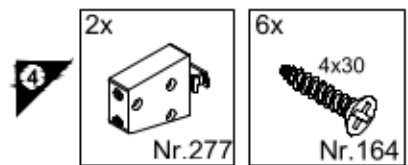
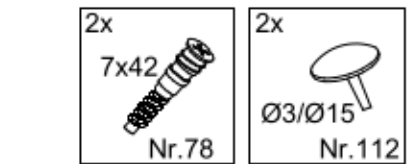
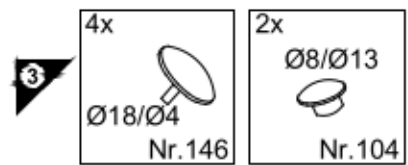

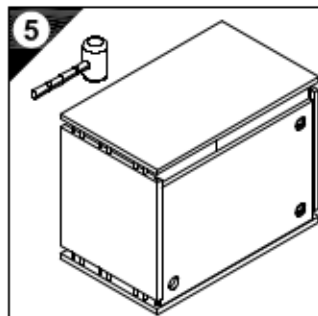
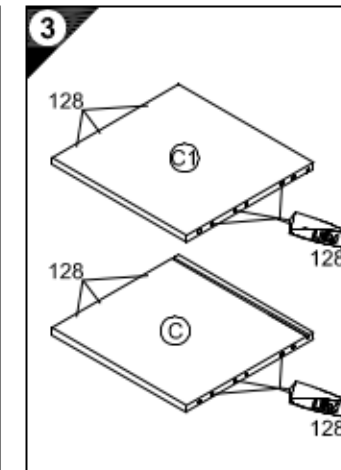
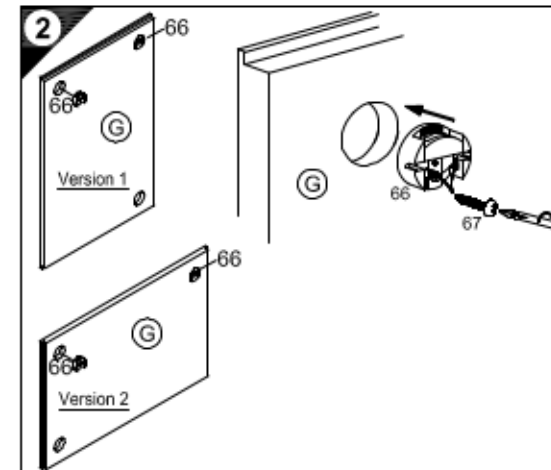
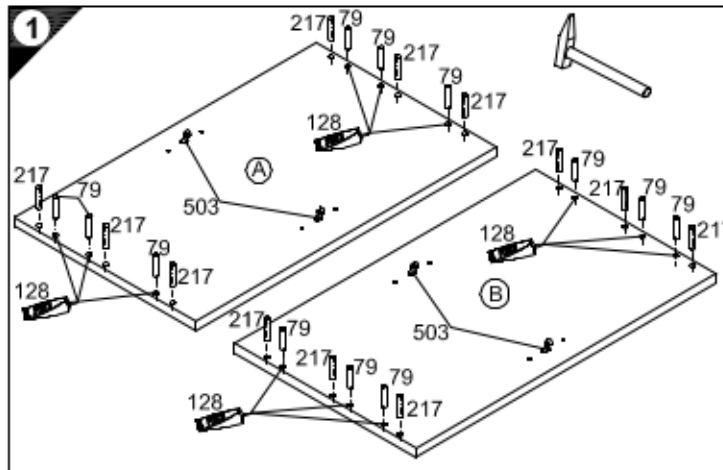
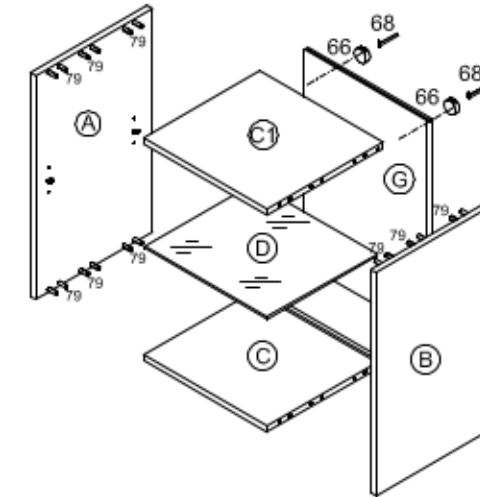
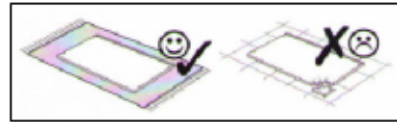
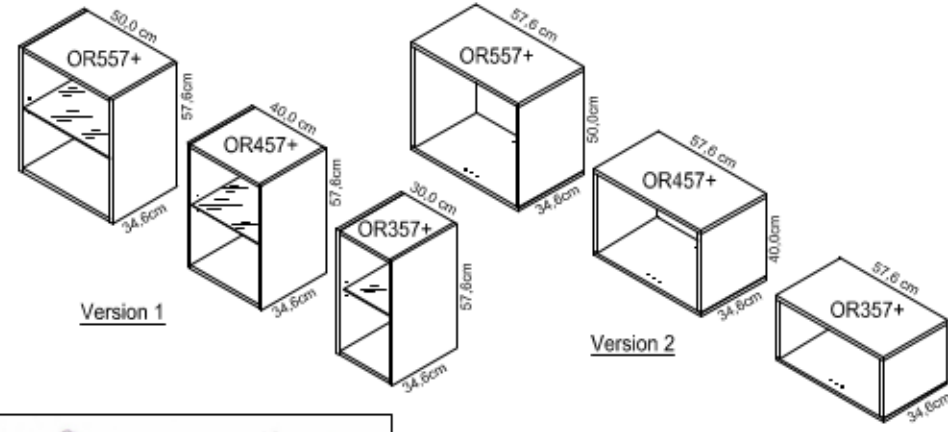
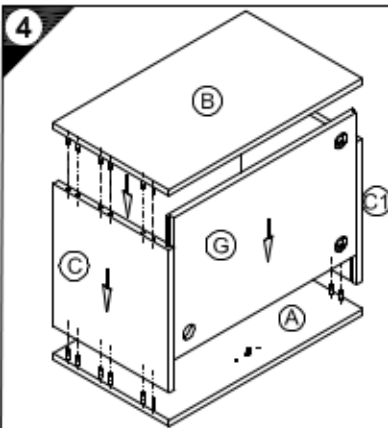
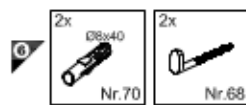
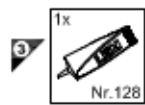
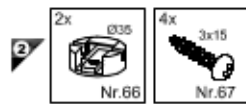
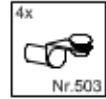
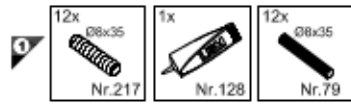
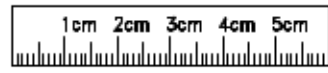

6 Untergrund und Befestigungsmittel auf Eignung prüfen!
 Check substructure and fixings for suitability!
 Contrôler si le support et les moyens de fixation sont bien adéquats !
 Ondergrond en bevestigingsmateriaal op functionaliteit controleren!
 ¡Comprobar el suelo y los medios de fijación en cuanto a su aptitud!
 Controllare l'idoneità del fondo e del materiale di fissaggio!
 Основание и крепежный материал проверить на пригодность!
 Podłoże oraz materiały do zamocowania sprawdzić na ich przydatność!
 Az alapfelületet és a rögzítő anyagokat megfelelőség szempontjából ellenőrizni kell!
 Preverite, če se ujemajo spodnja stran in pritrilna sredstva!
 Tarkista alustan ja kiinnittinten sopivuus.
 Kontrollera att underlaget och fästmedlen är lämpliga!

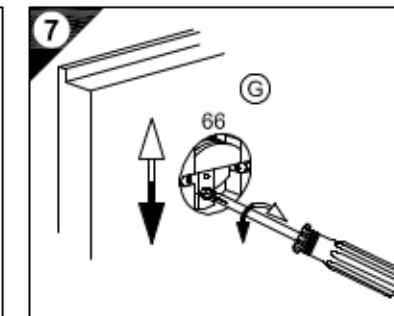

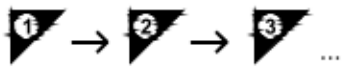
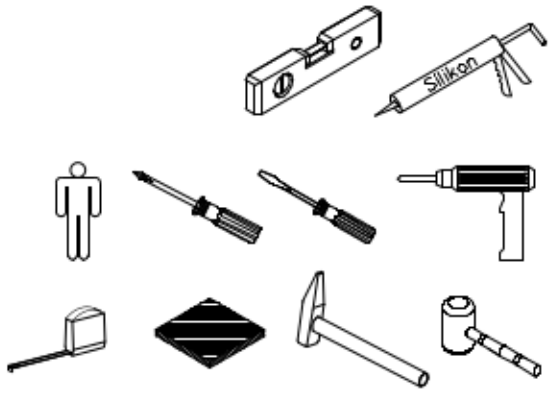

- | | | | |
|----------|--------------|--------------|--------------|
| 1 | 8x
Nr.98 | 2x
Nr.367 | 4x
Nr.502 |
| | 2x
Nr.89 | 4x
Nr.451 | 2x
Nr.158 |
| | 2x
Nr.535 | | |
| 2 | 8x
Nr.76 | 14x
Nr.80 | 2x
Nr.81 |

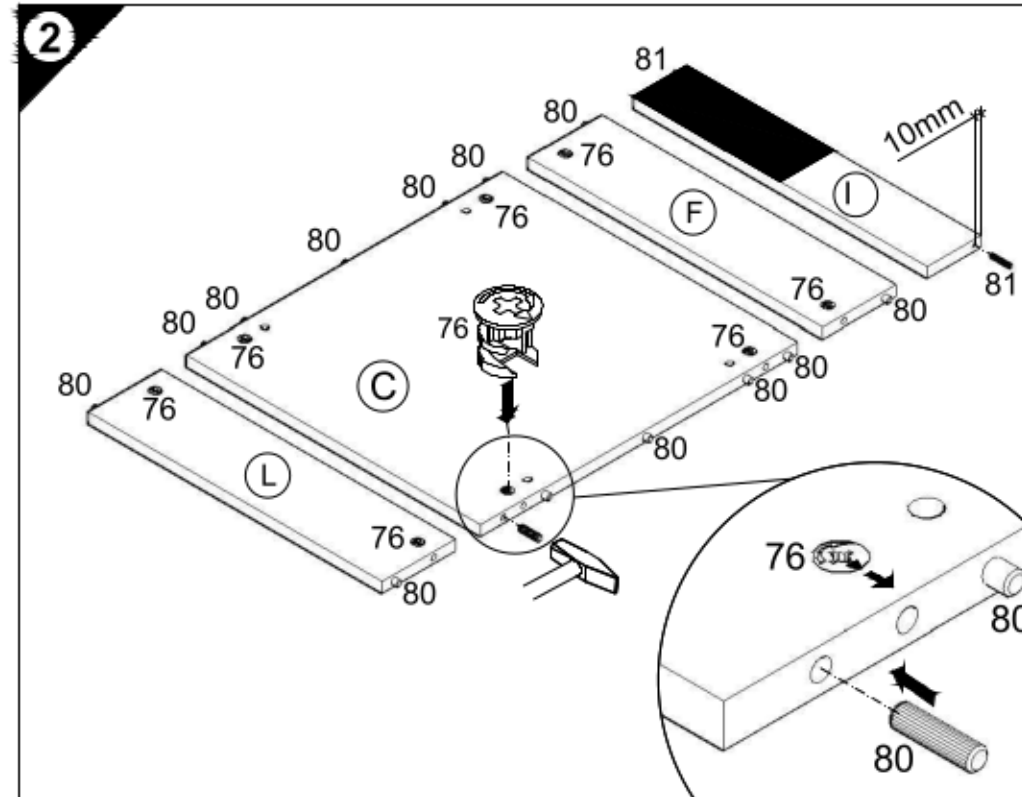
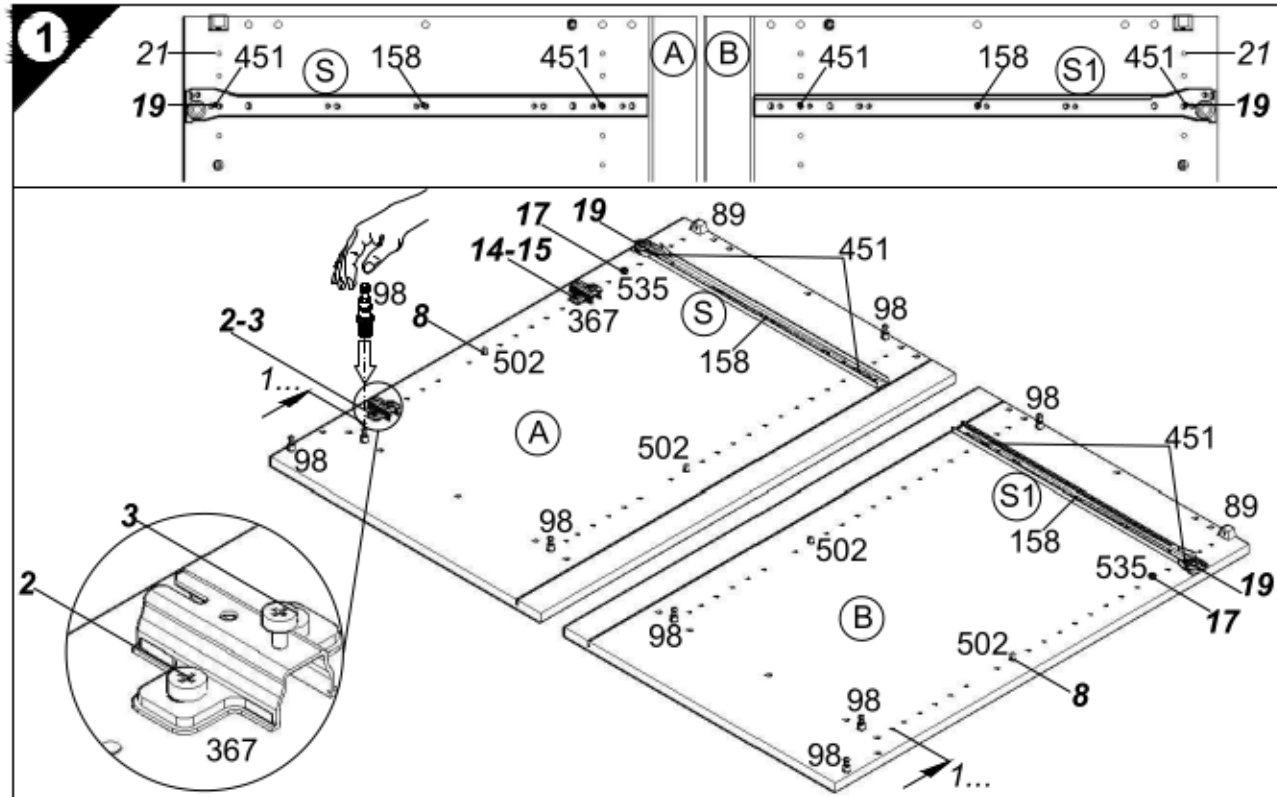
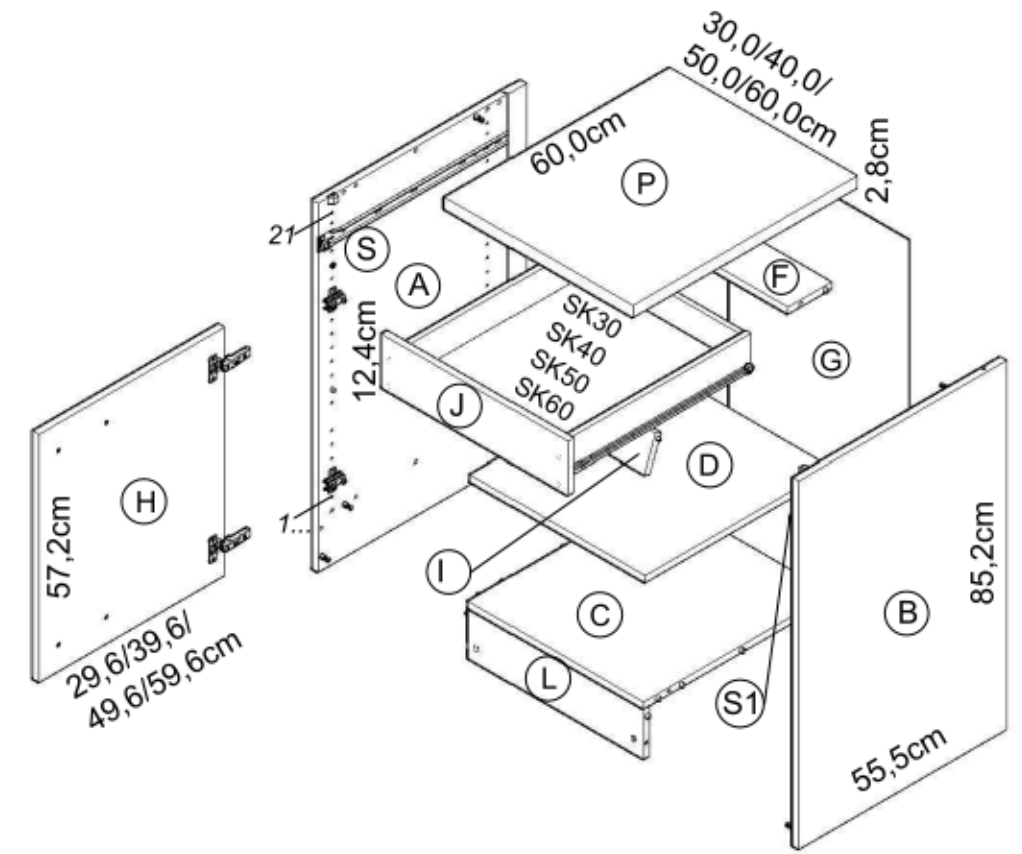
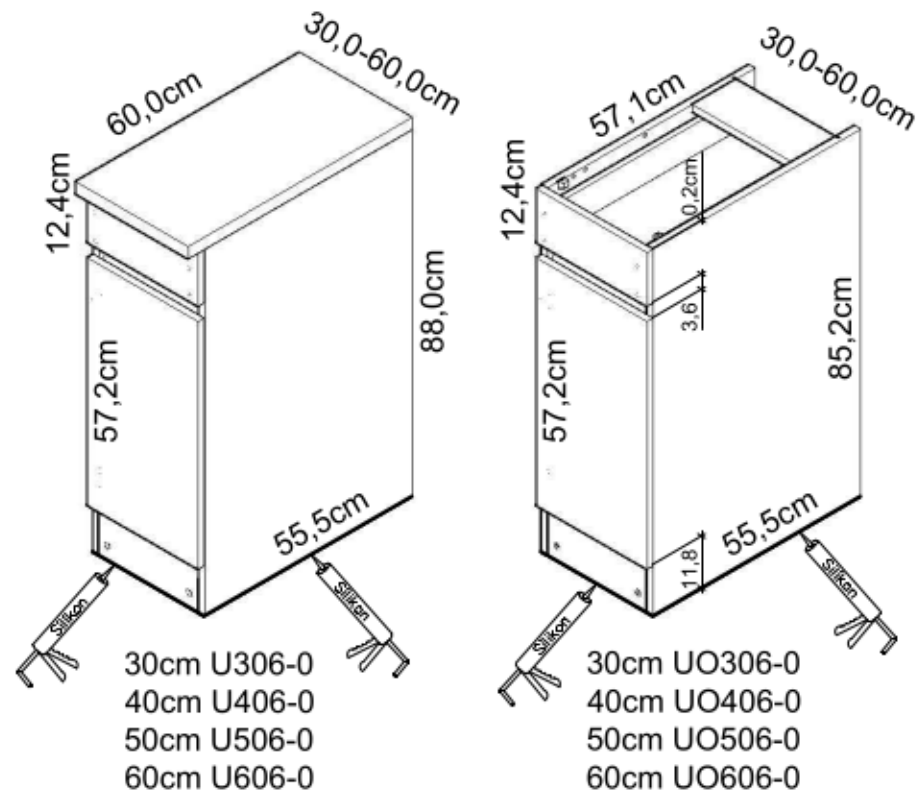

1 → 2 → 3 ...

- 5** 16x
Nr.204
- 6** 2x Nr.365 4x Nr.102
- 8** 2x 4x30
Nr.424
- 9** 4x 4x30
Nr.164

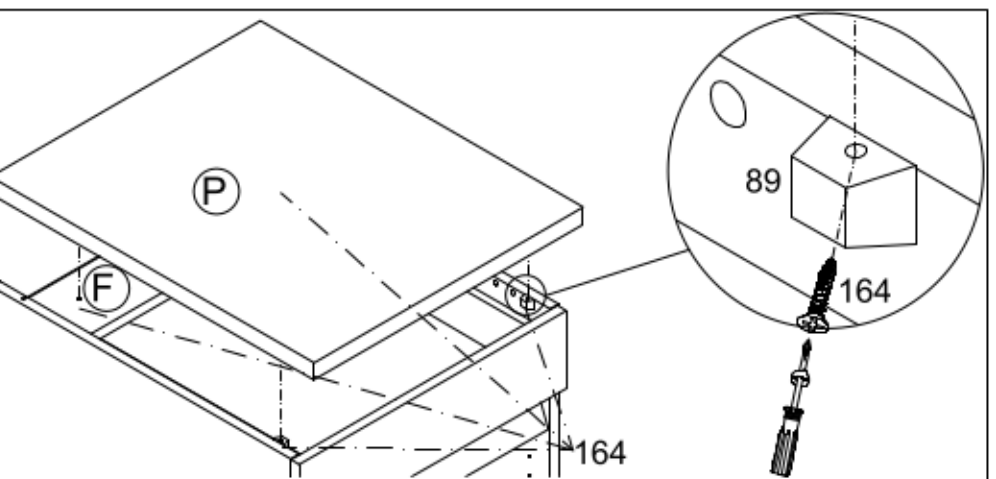
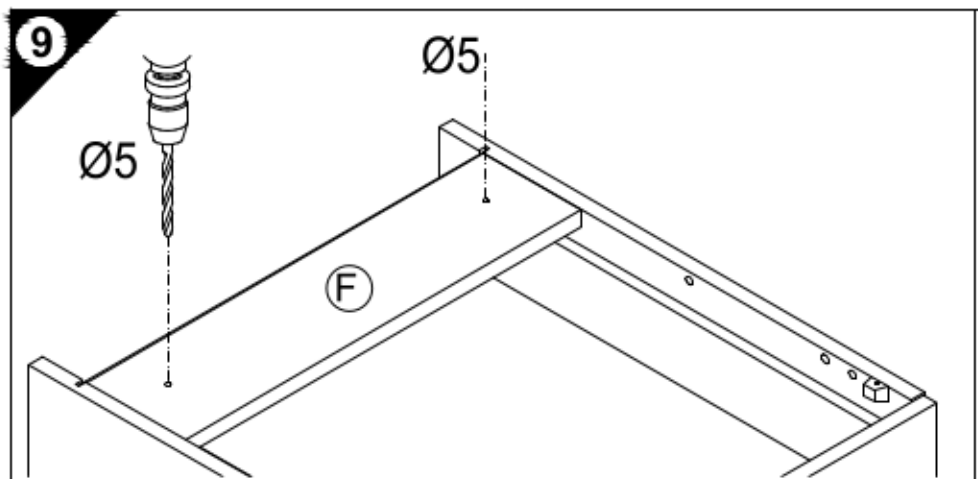
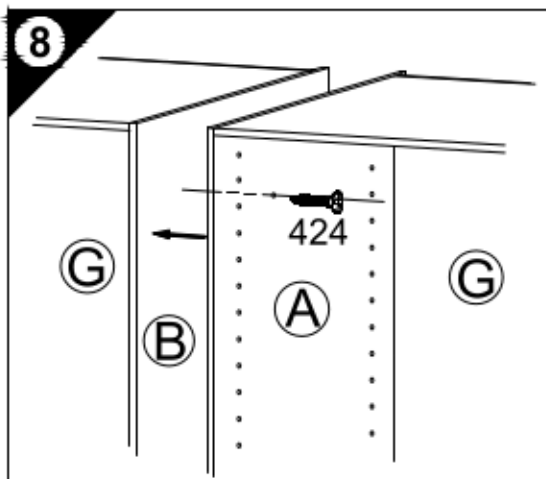
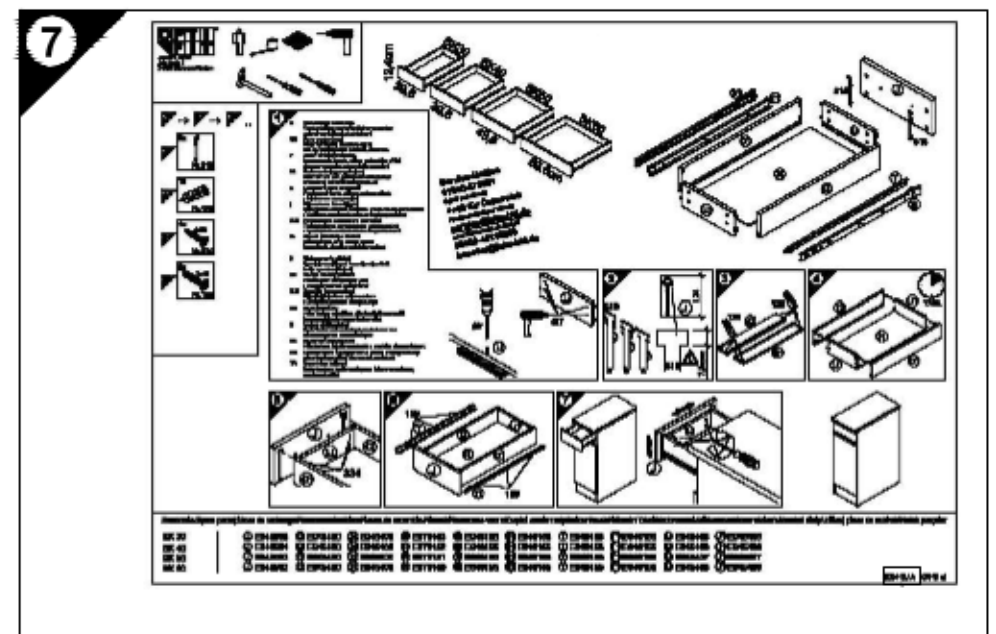
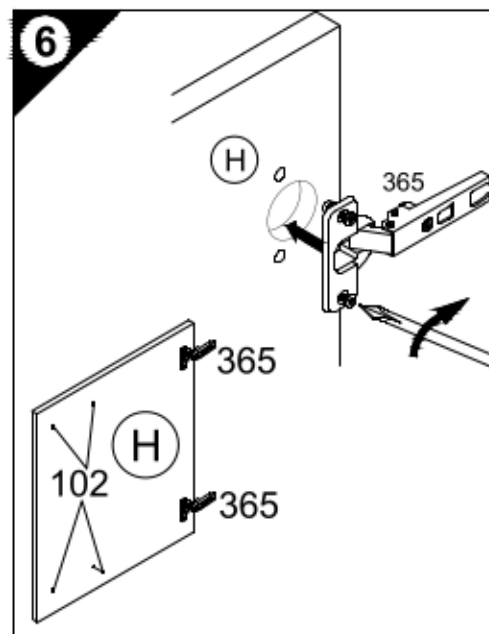
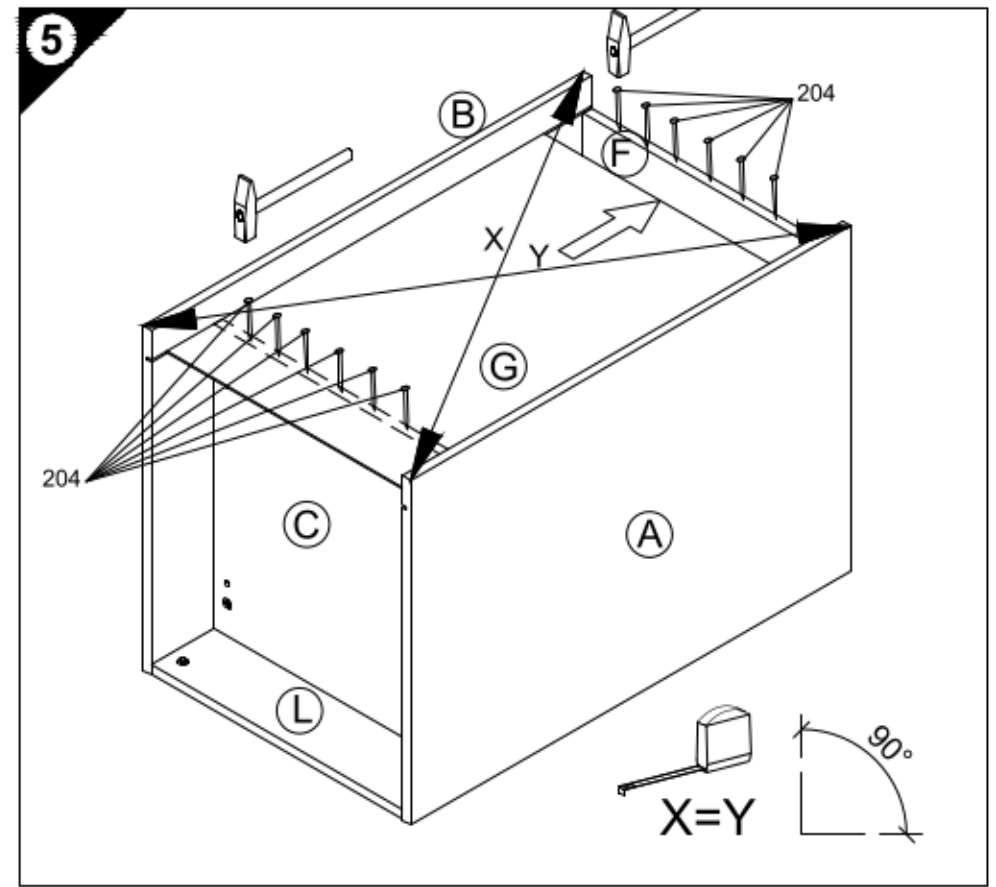
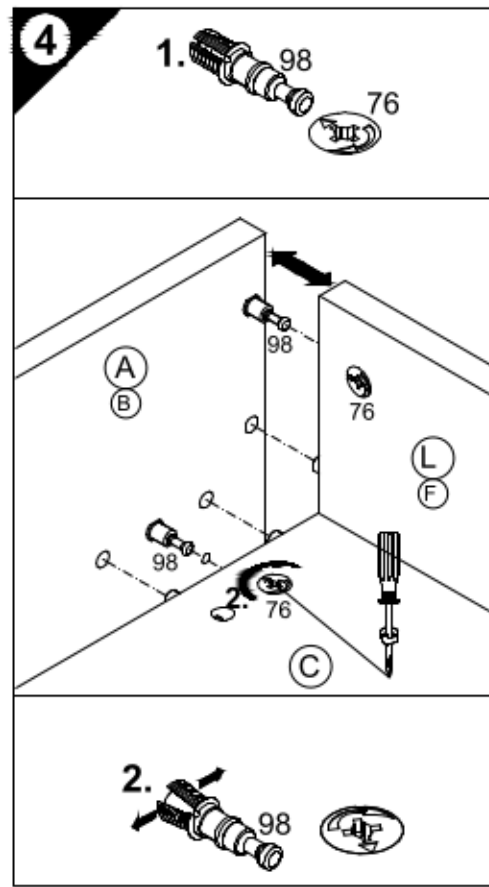
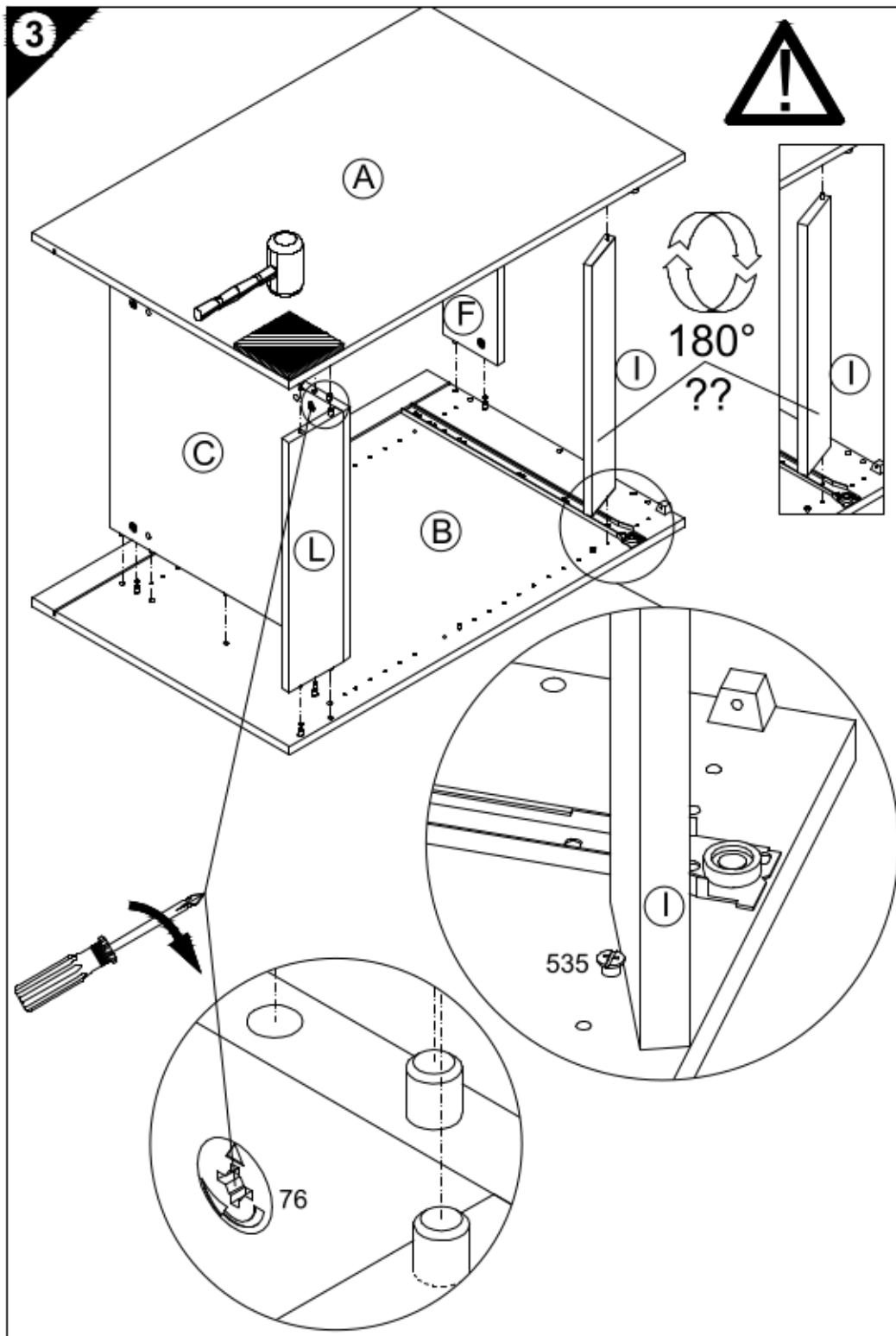

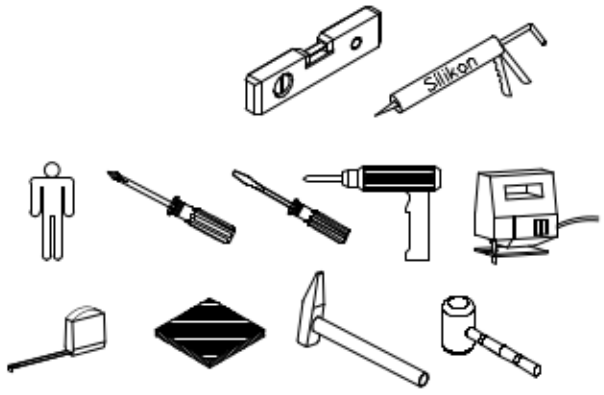

- 1**
- 2x Nr.98
- 4x 6,3x11,5 Nr.535
- 10x Nr.315
- 10x 3,5x15 Nr.181
- 2x Nr.523
- 4x 6,3x13 Nr.274
- 2**
- 2x Nr.76
- 2x Ø8x30 Nr.80
- 4x Nr.536

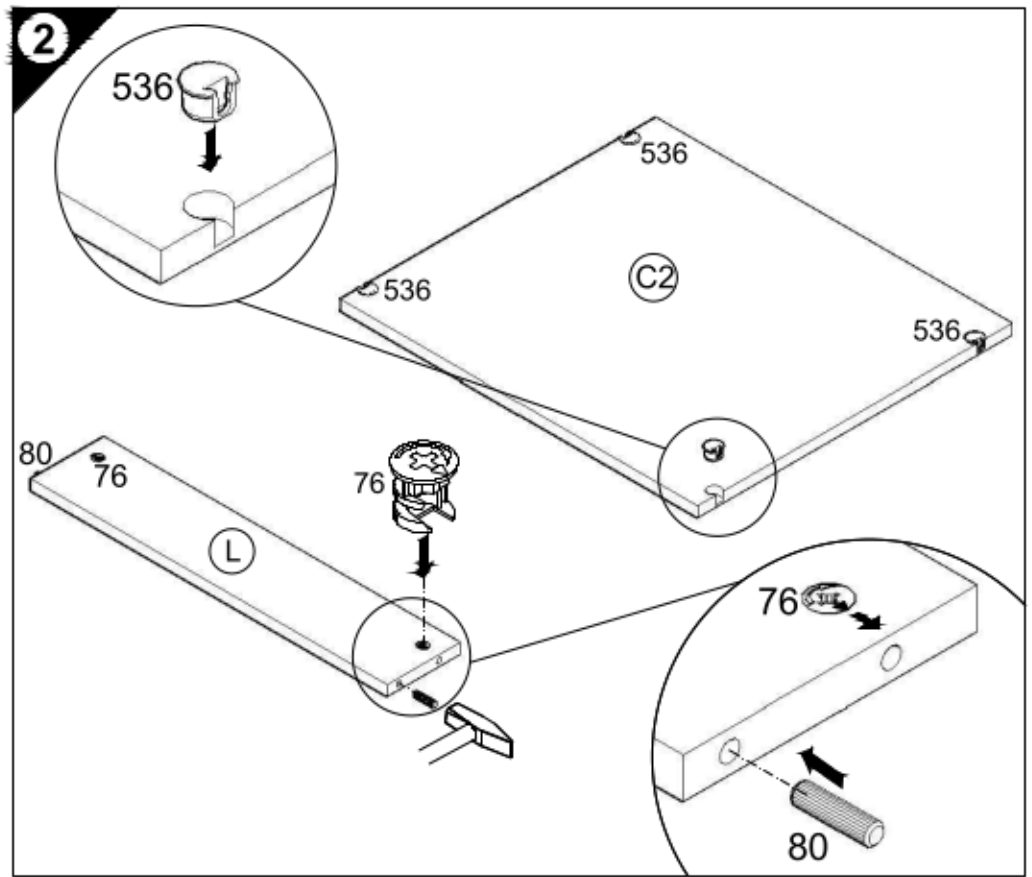
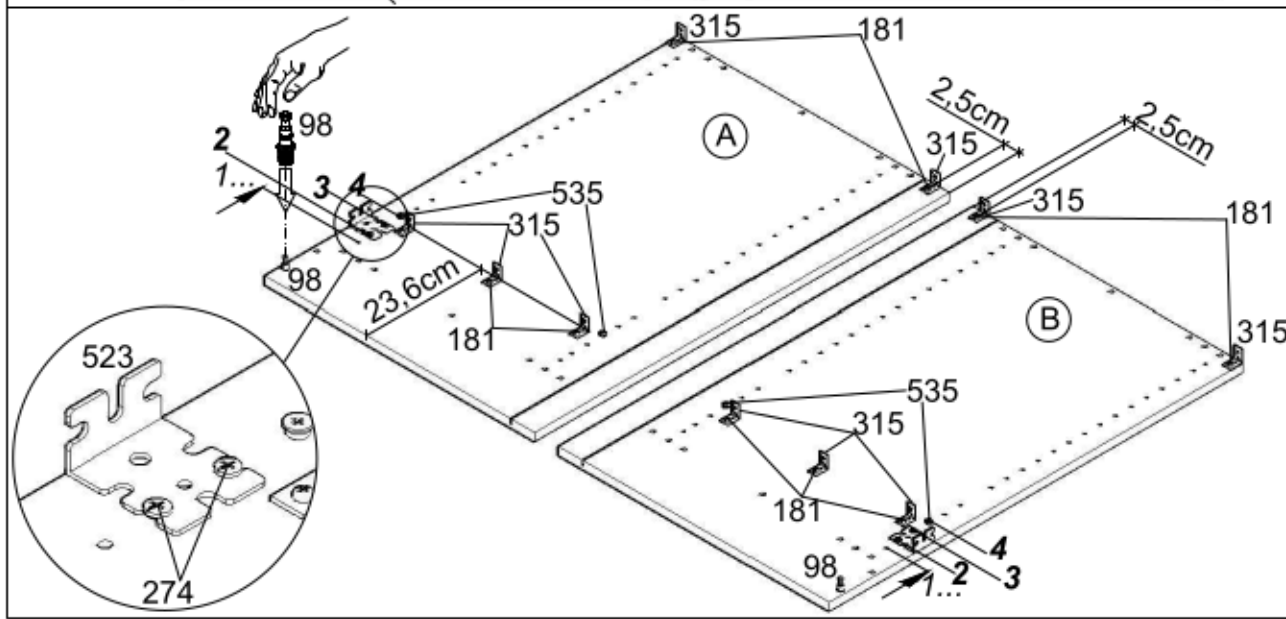
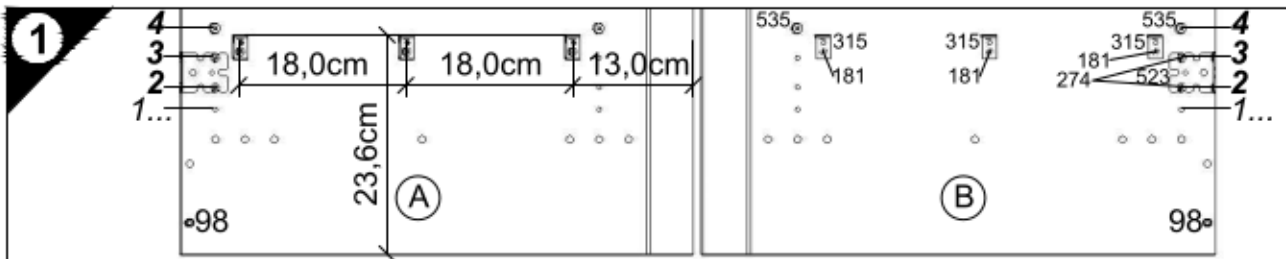
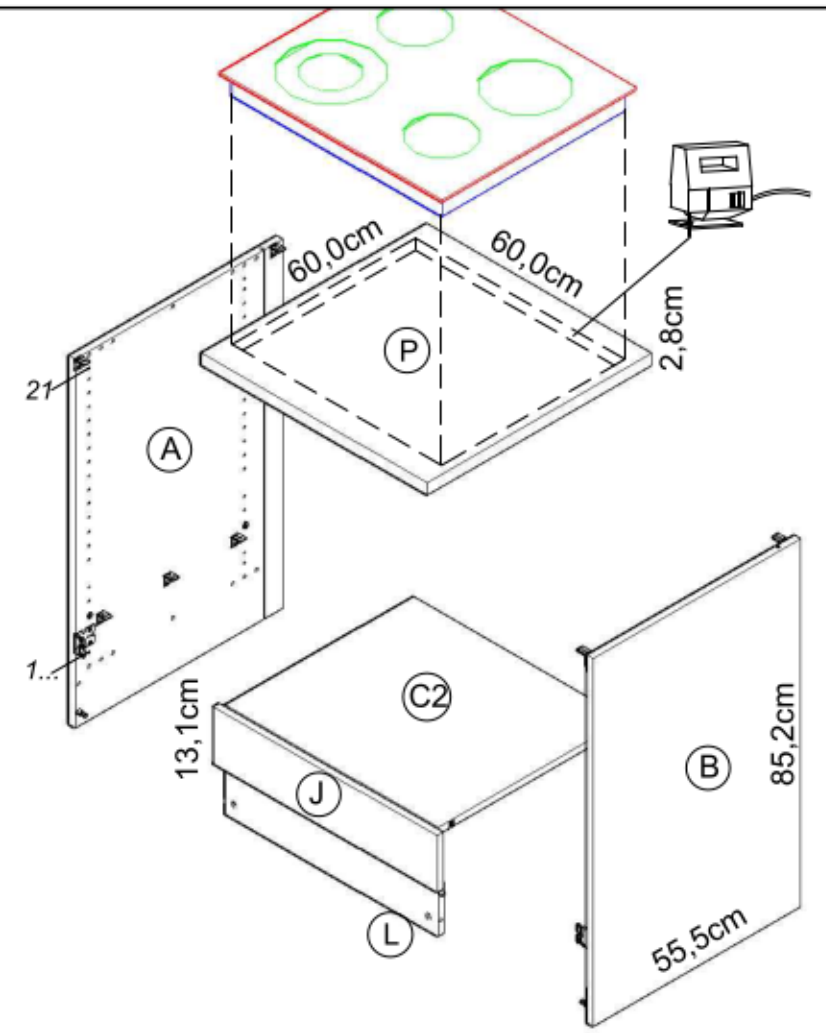
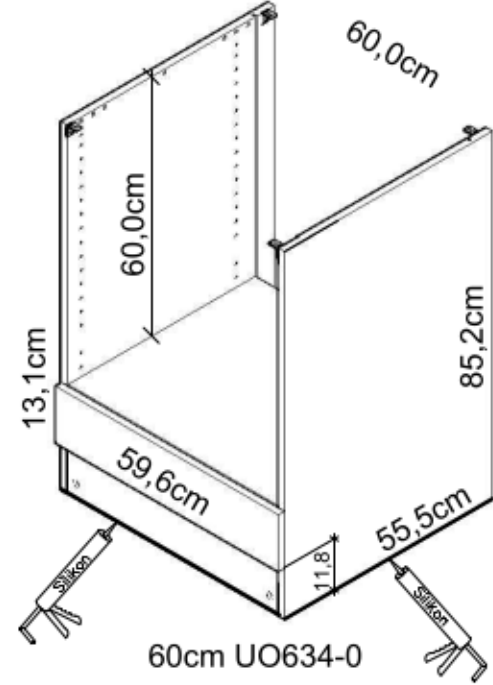
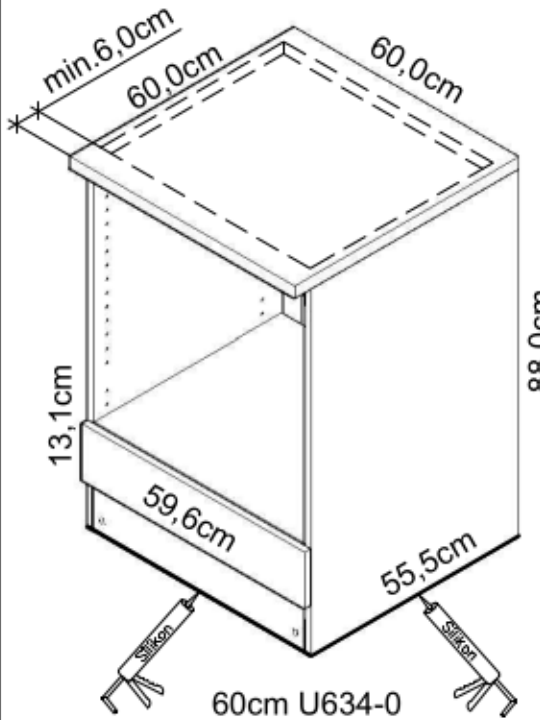

1 → 2 → 3 ...

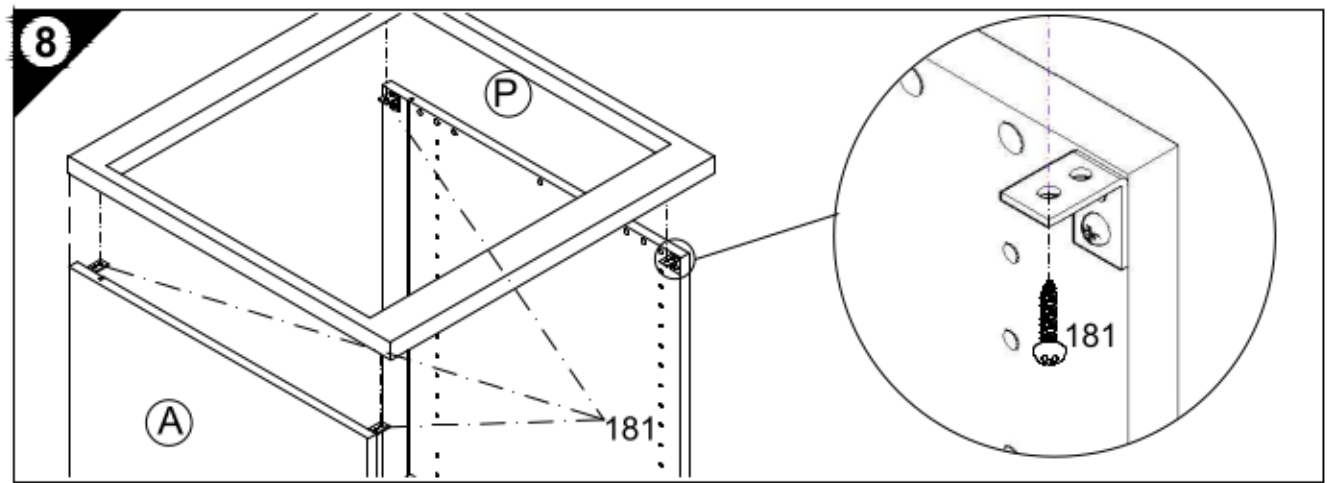
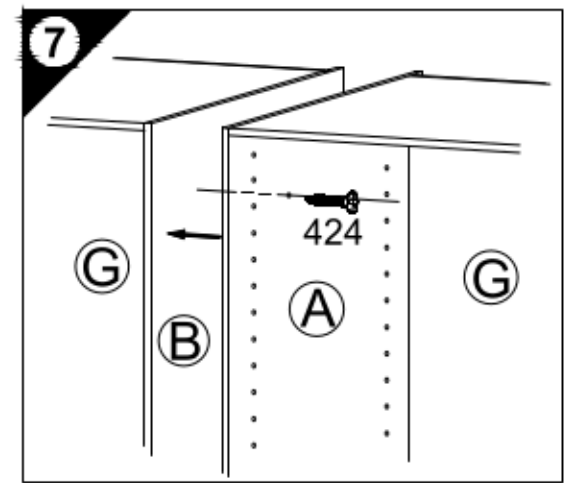
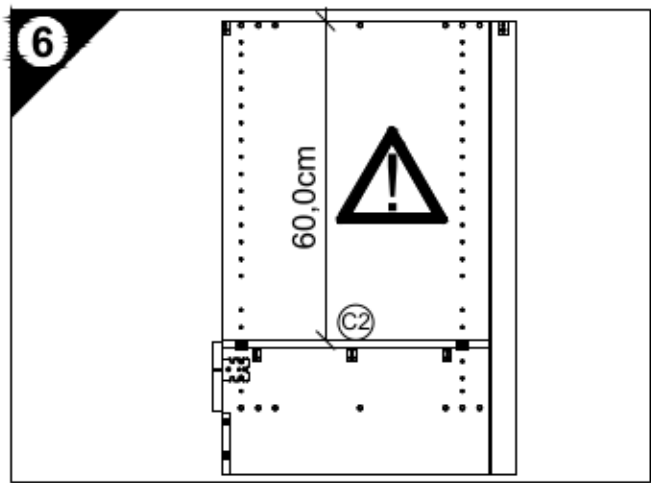
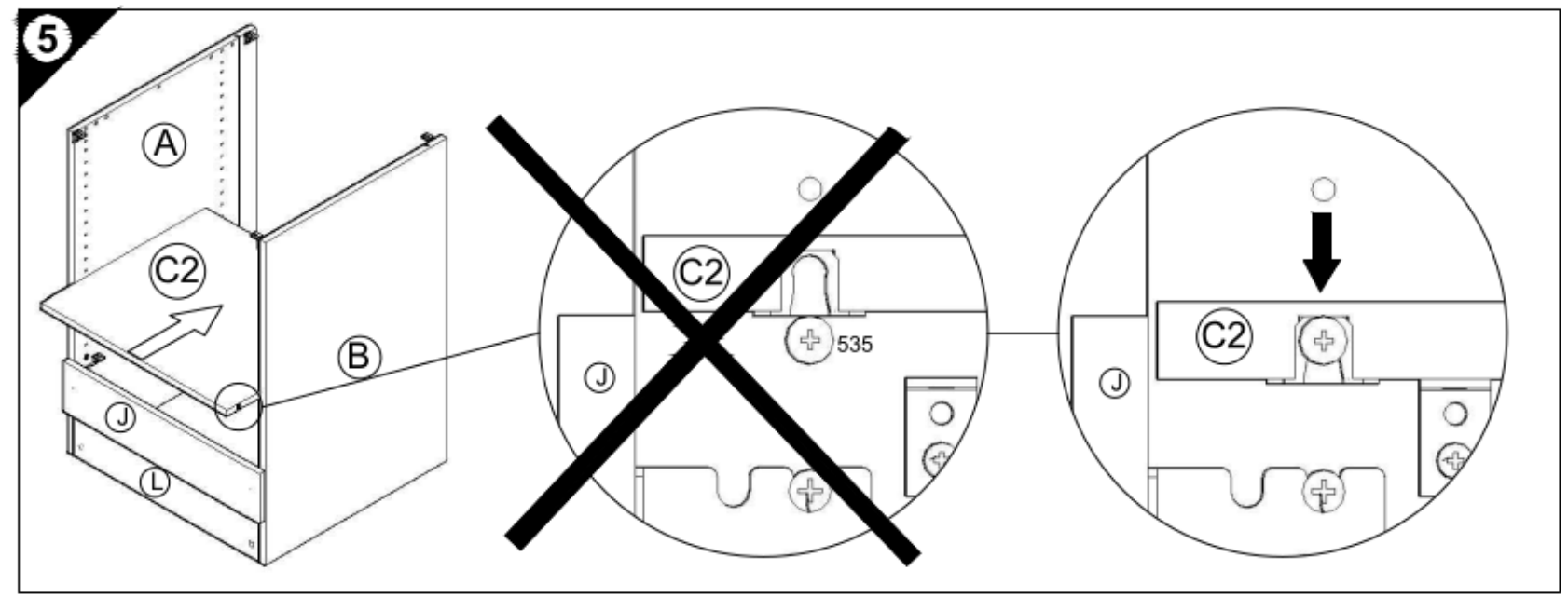
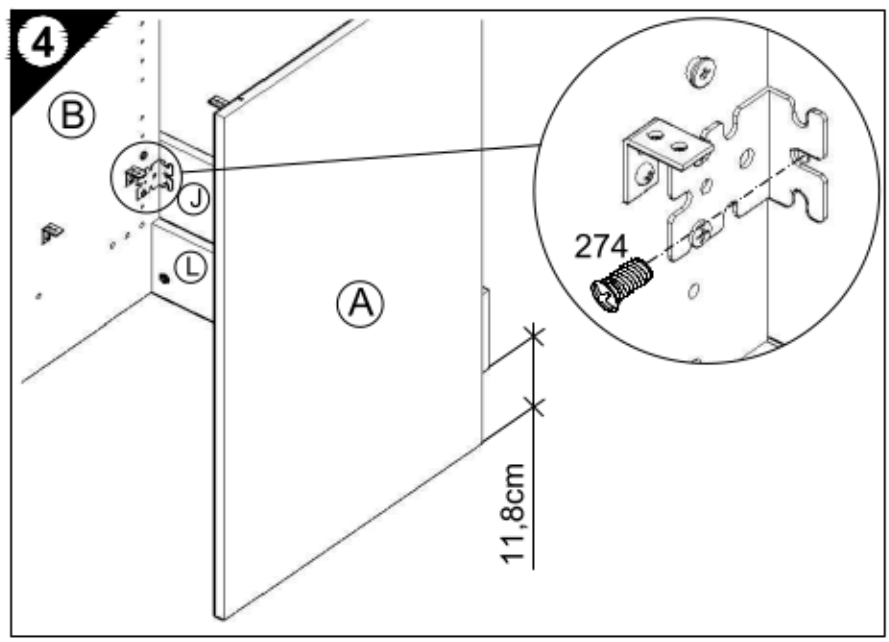
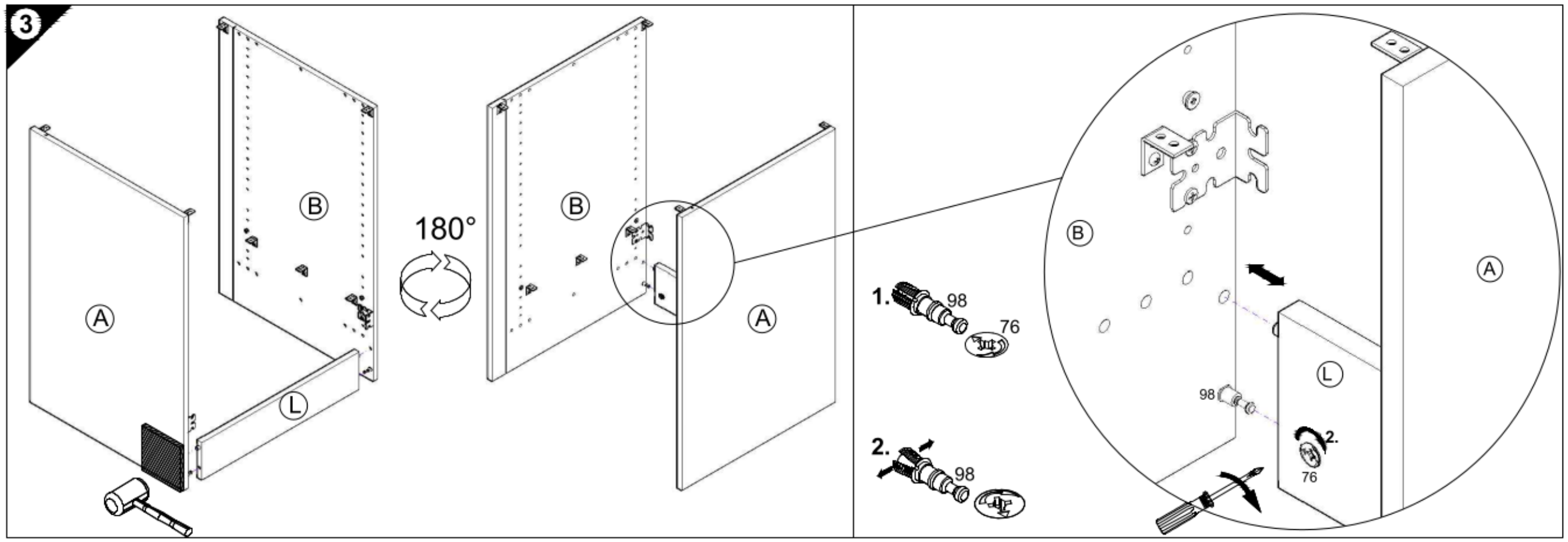
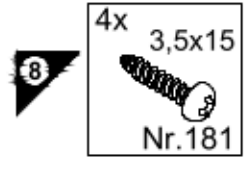
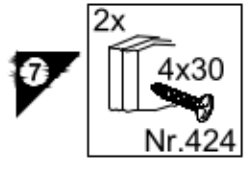
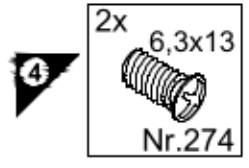

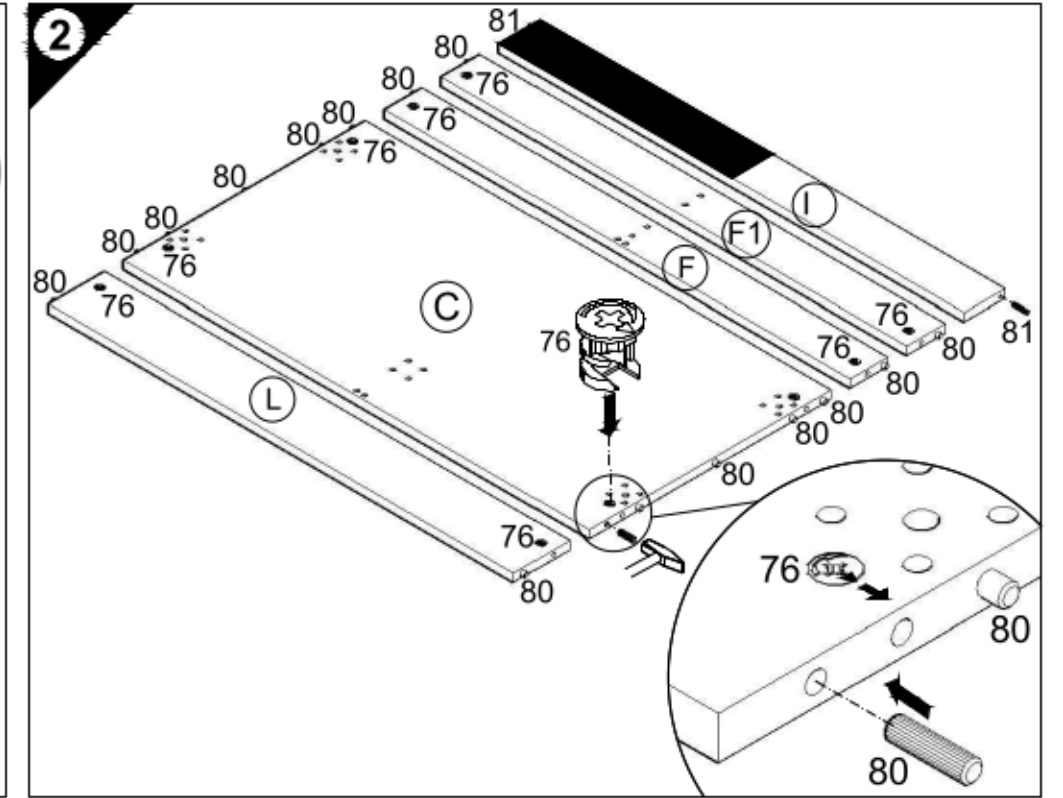
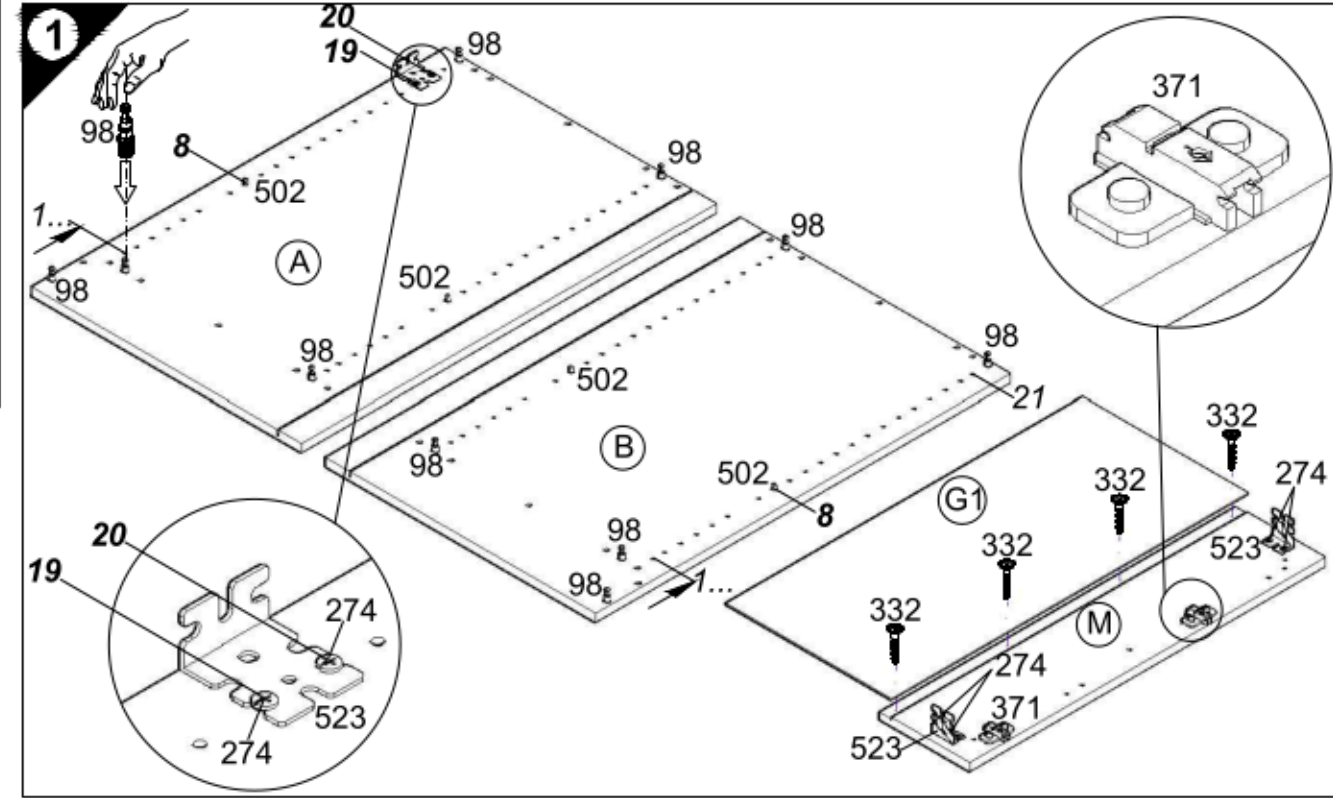
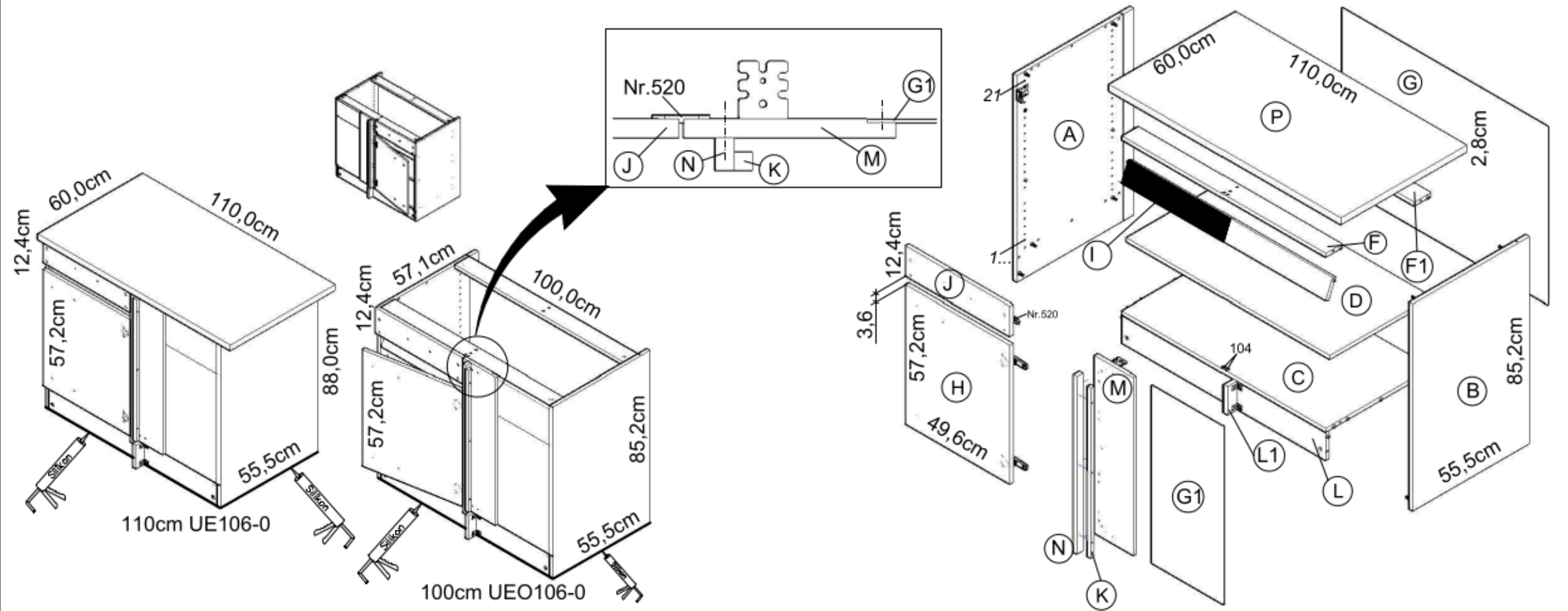
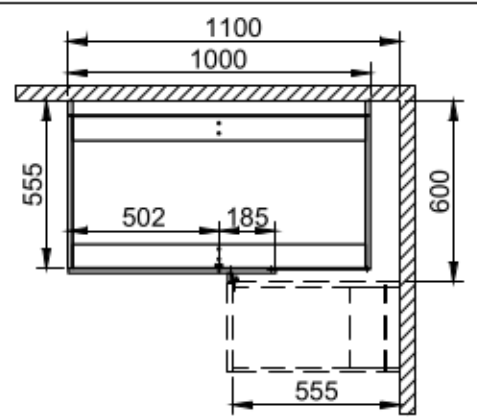
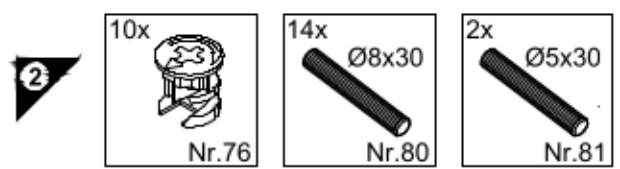
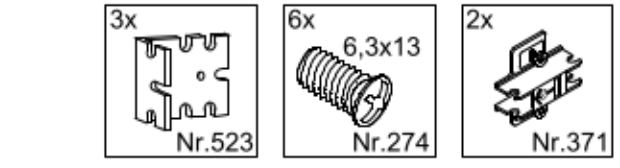
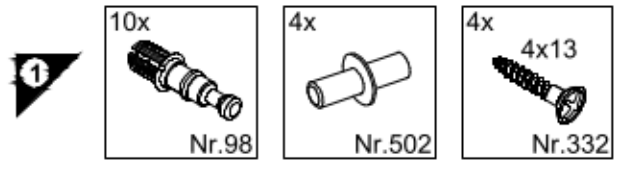
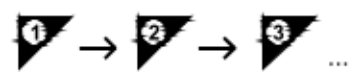
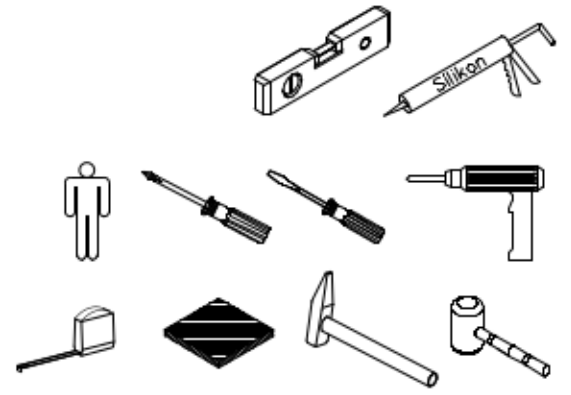

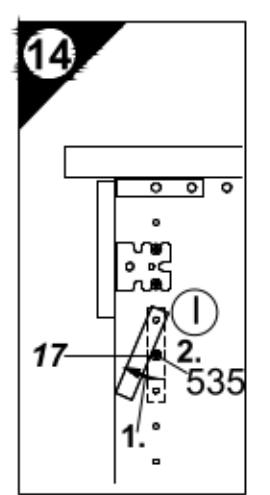
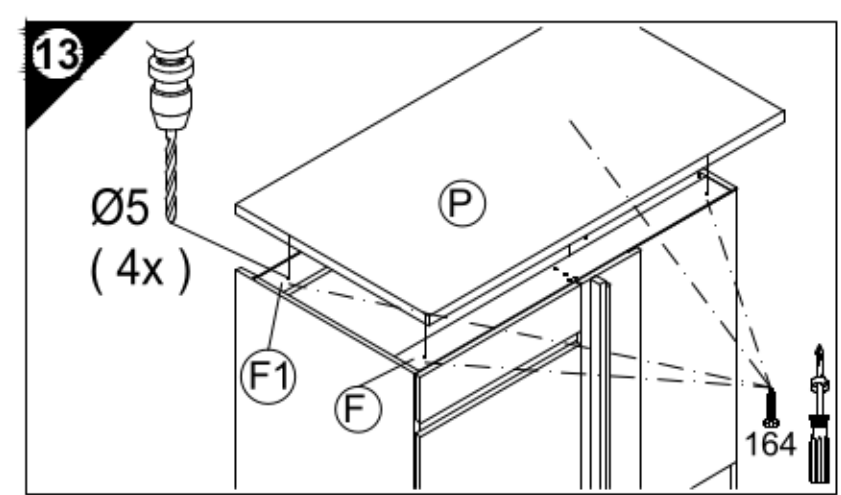
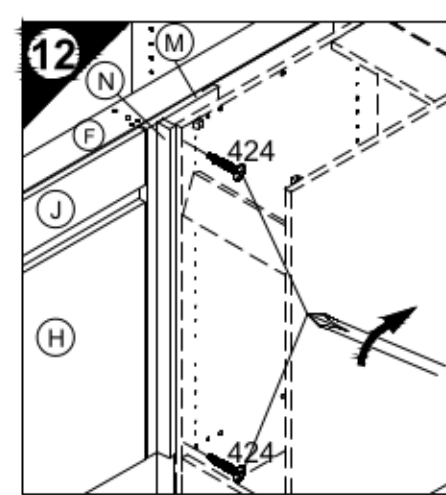
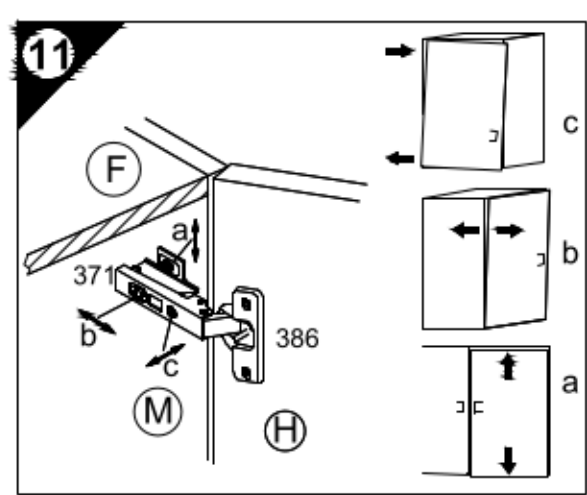
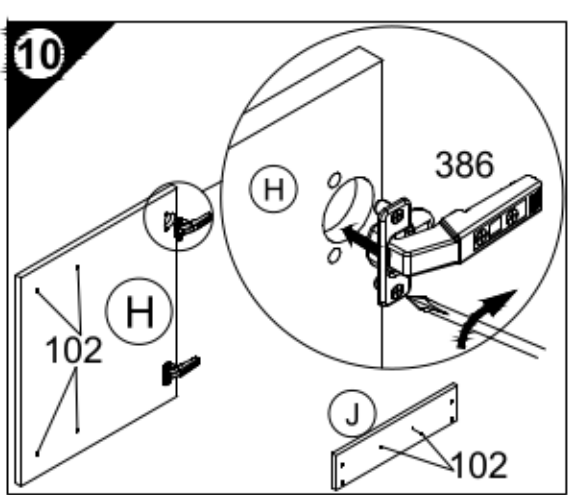
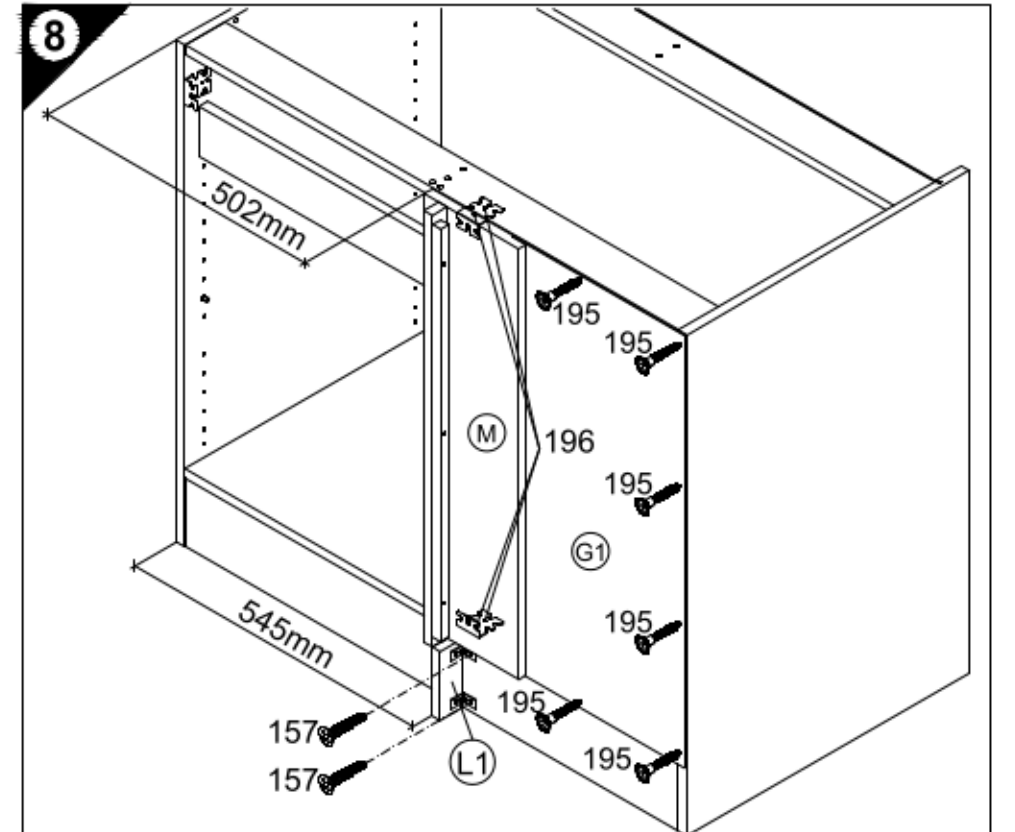
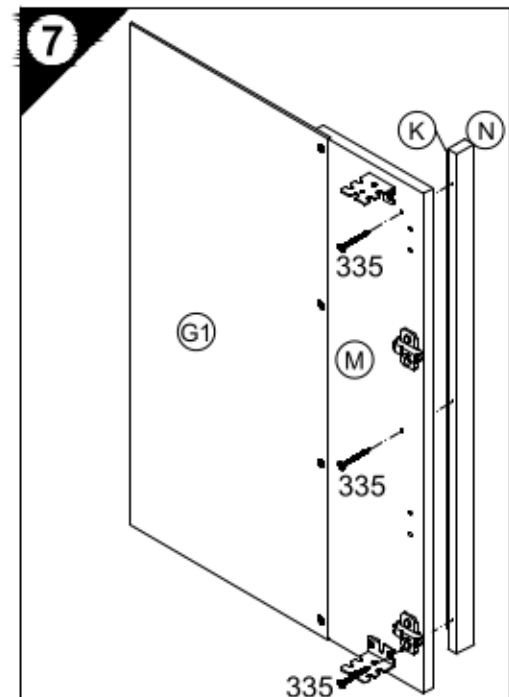
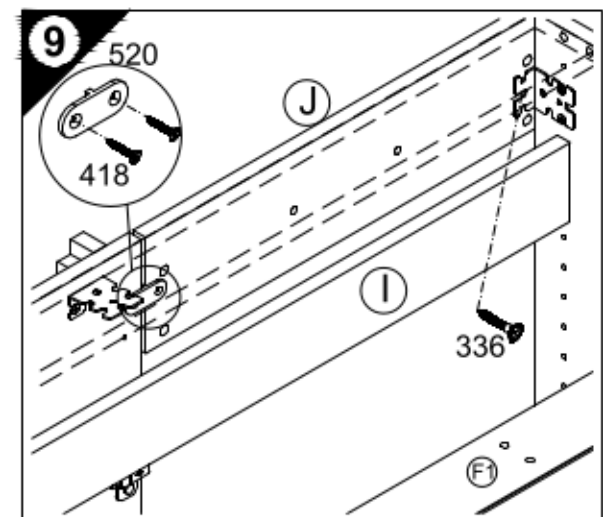
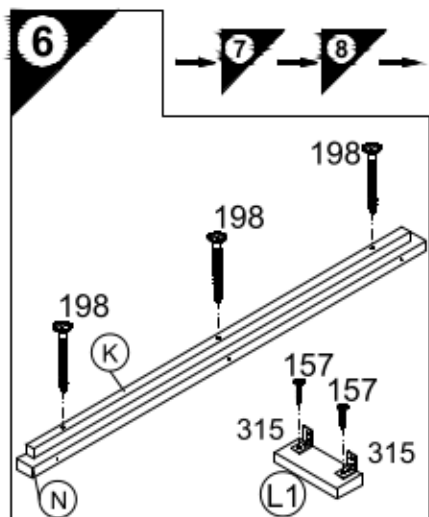
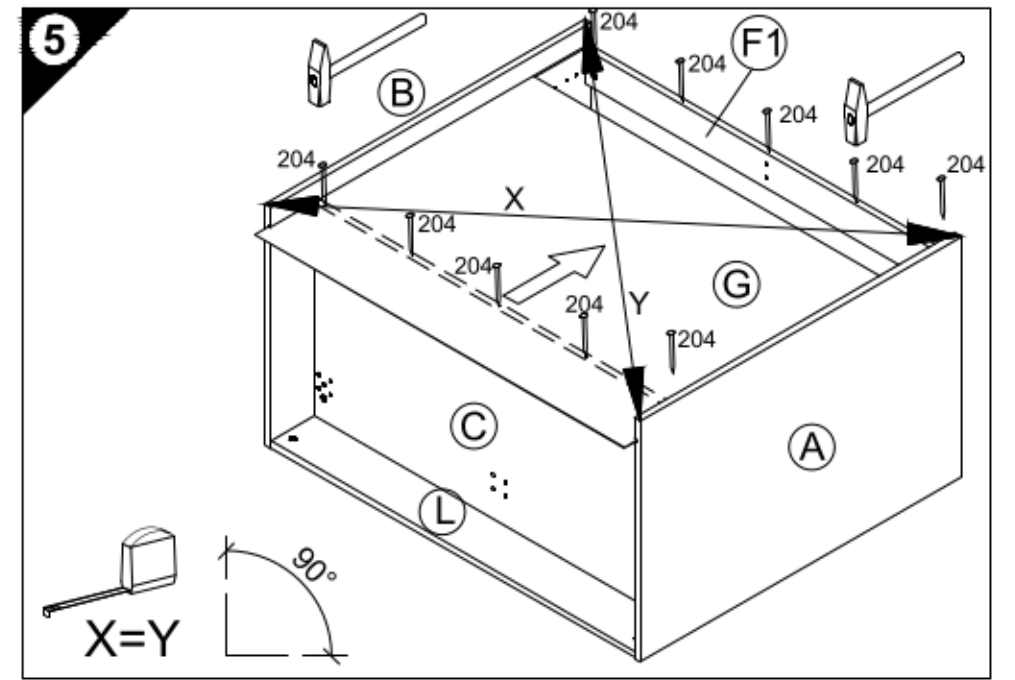
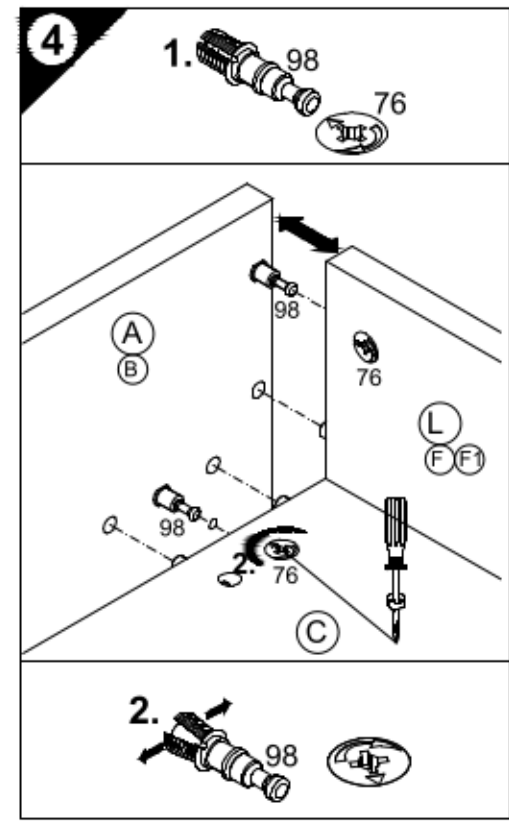
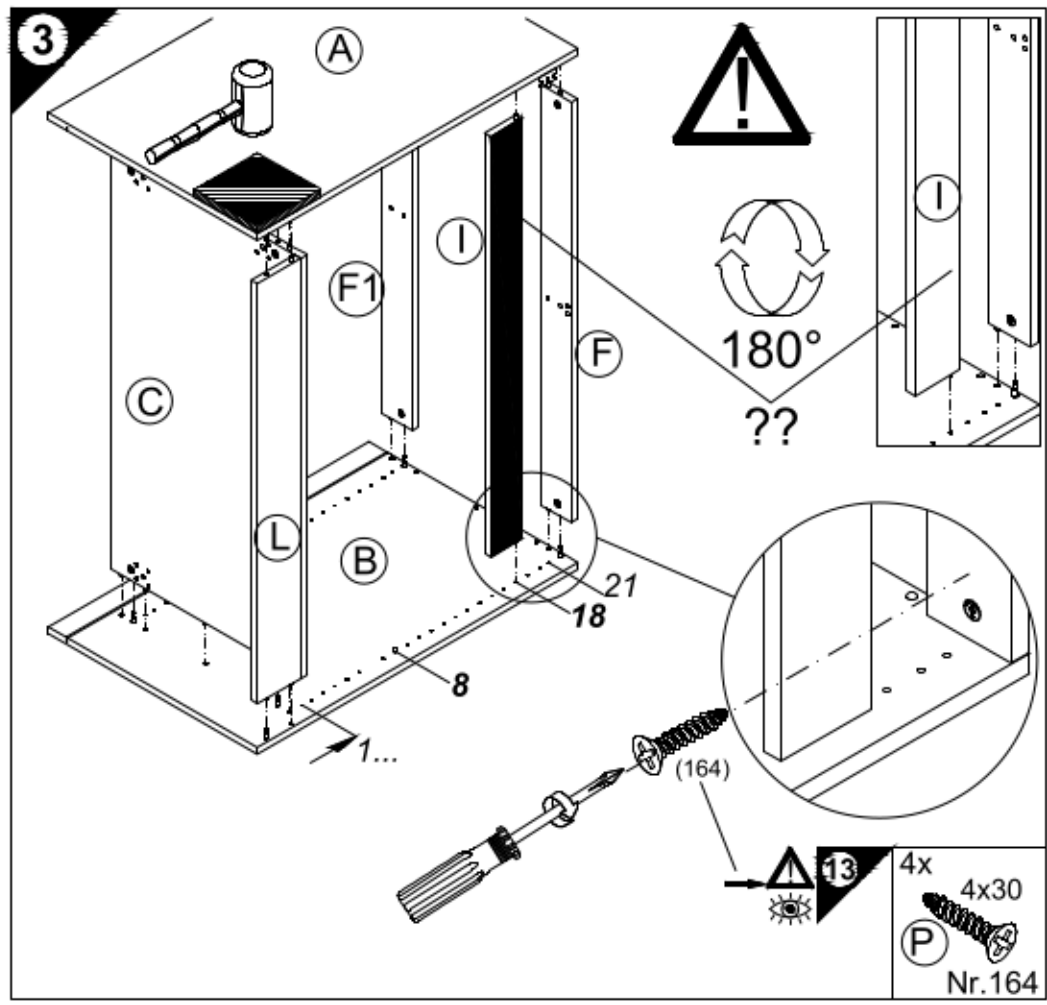
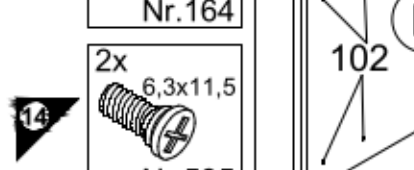
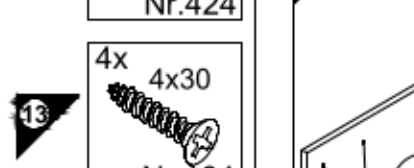
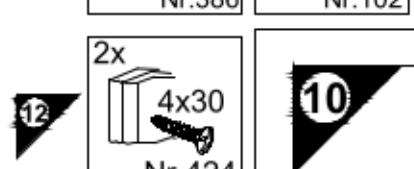
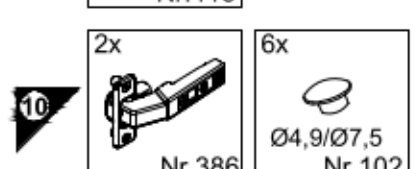
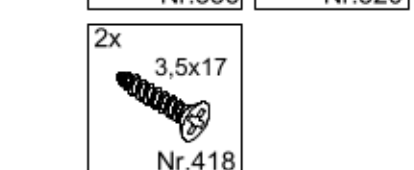
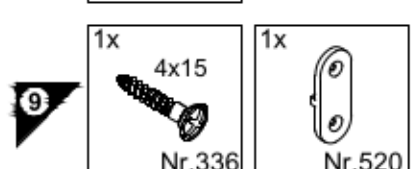
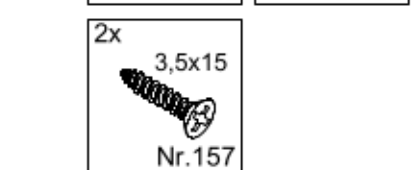
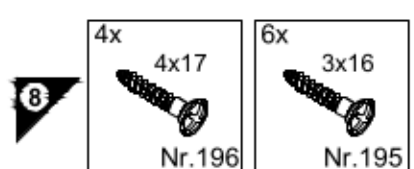
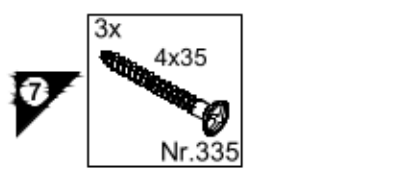
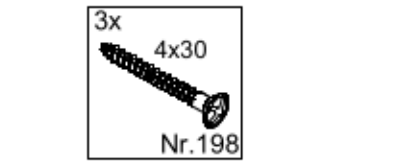
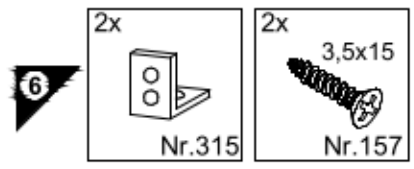
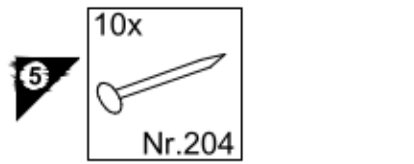

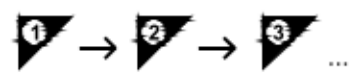
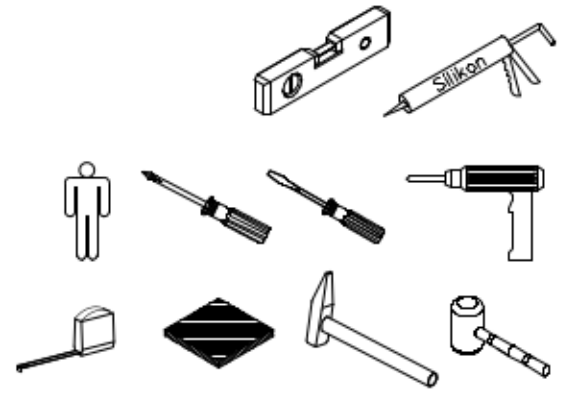

- | | | | |
|----------|------------------------|-----------------------|-------------------|
| 1 | 8x
Nr.98 | 4x 6,3x11,5
Nr.535 | 2x
Nr.89 |
| | 12x 6,3x12,5
Nr.451 | 6x 4x15
Nr.158 | |
| 2 | 8x
Nr.76 | 14x Ø8x30
Nr.80 | 4x Ø5x30
Nr.81 |

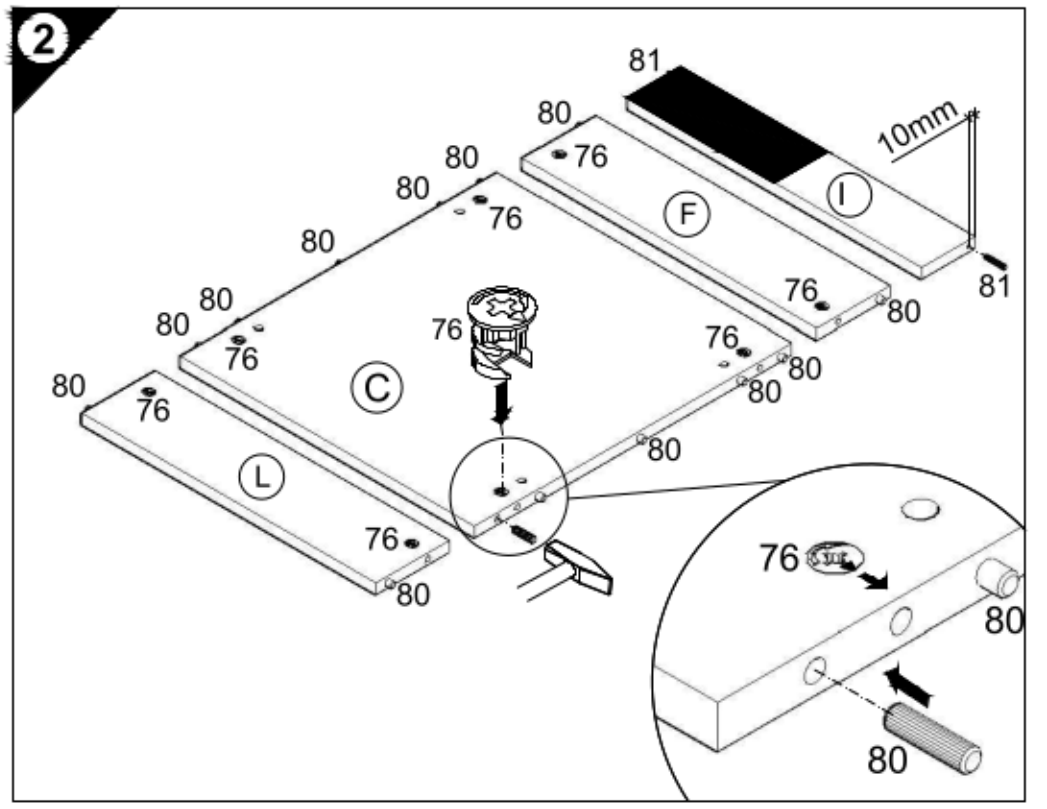
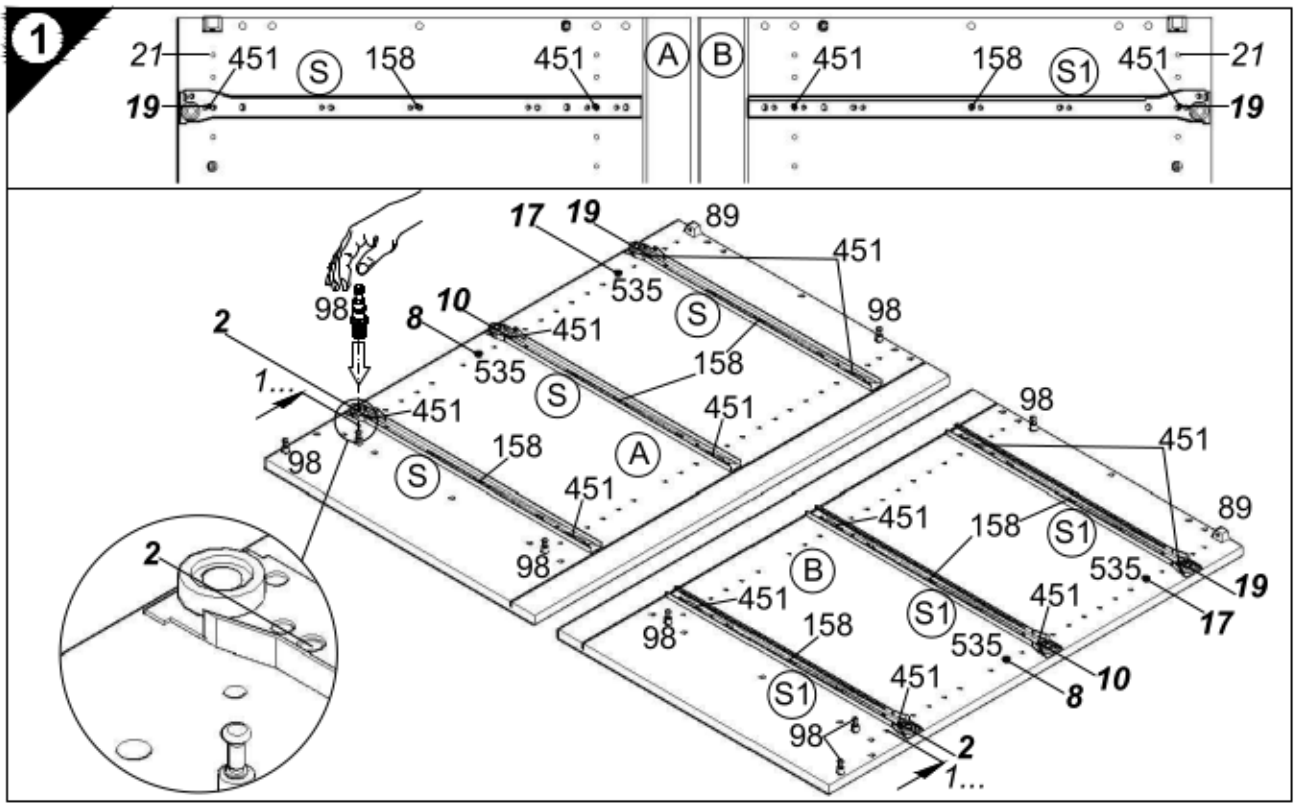
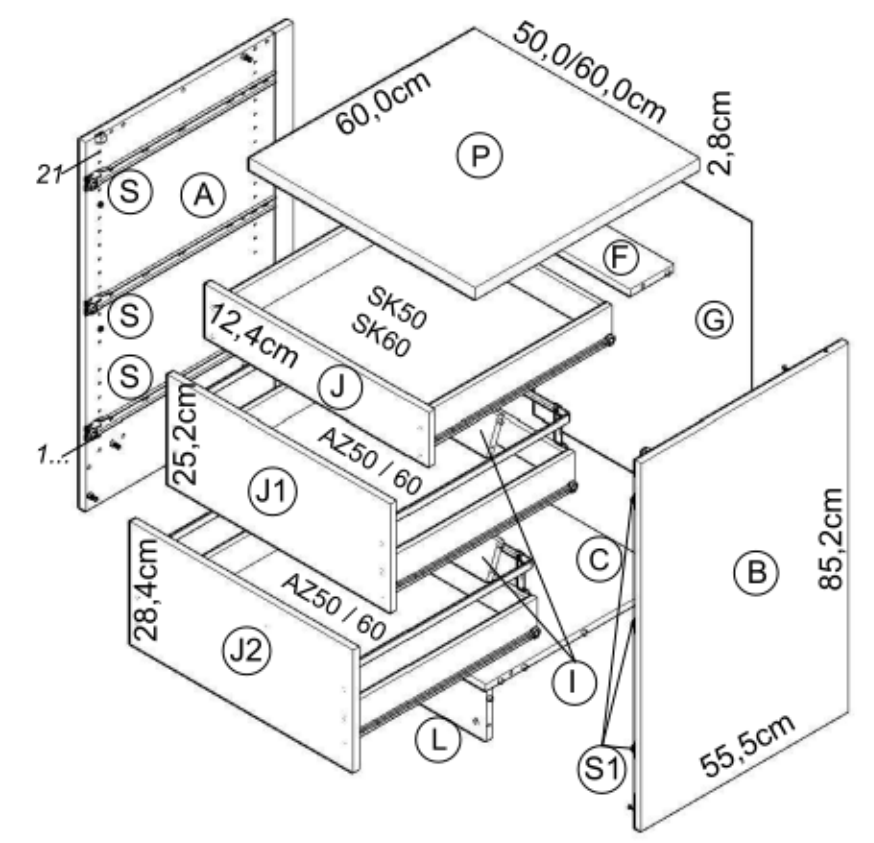
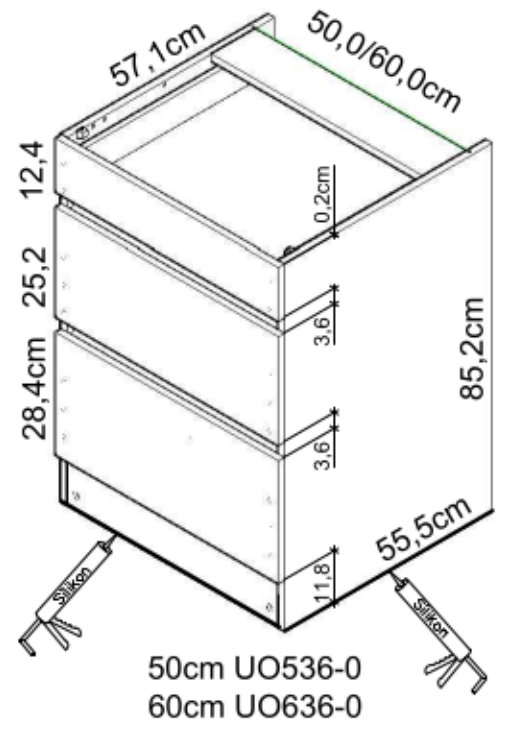
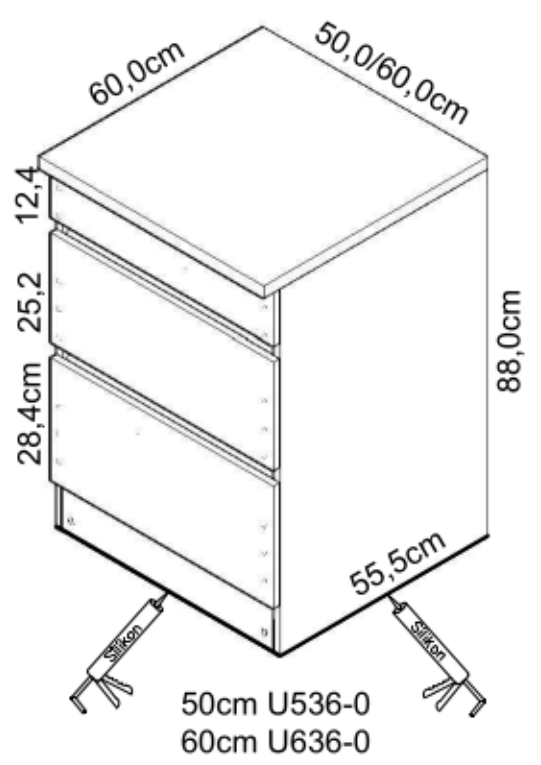

1 → 2 → 3 ...

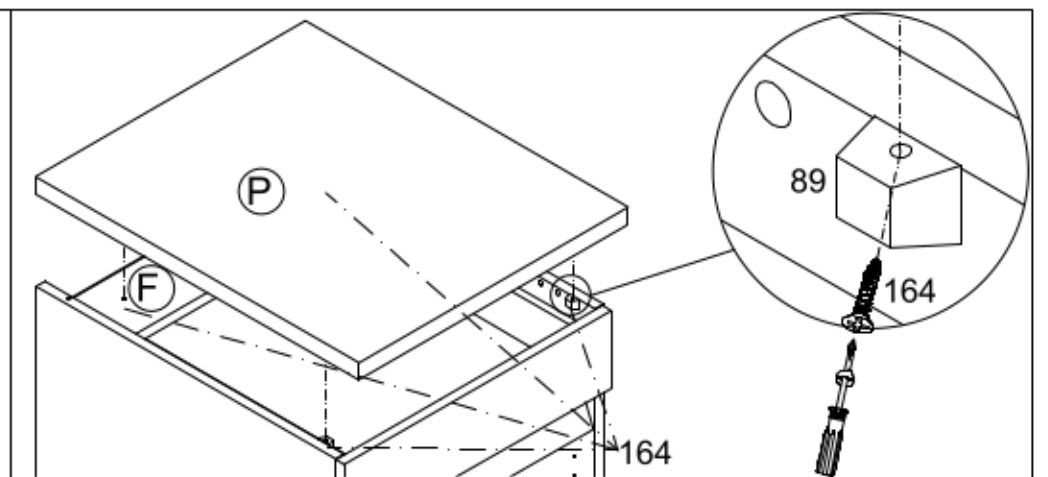
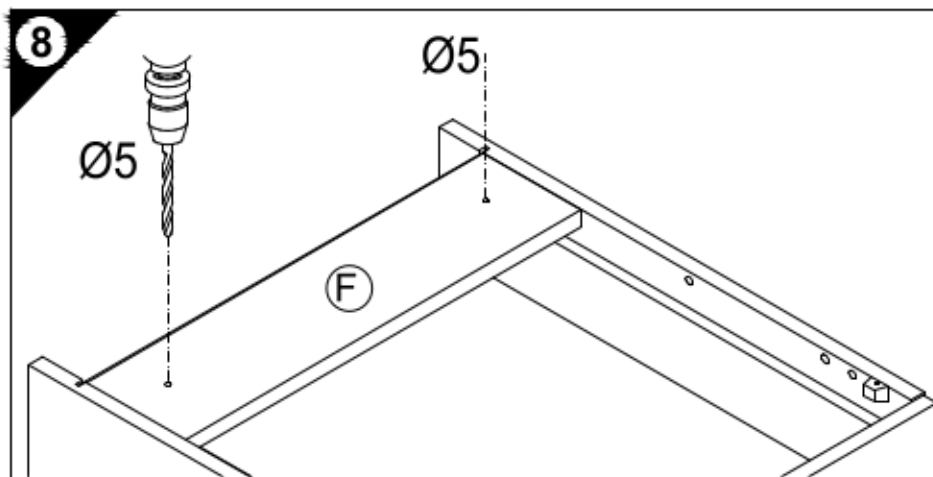
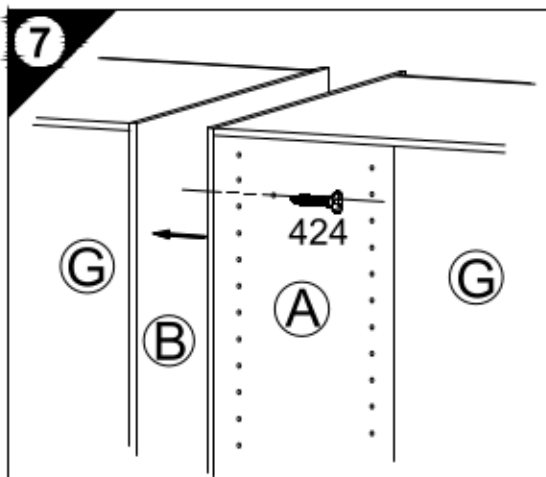
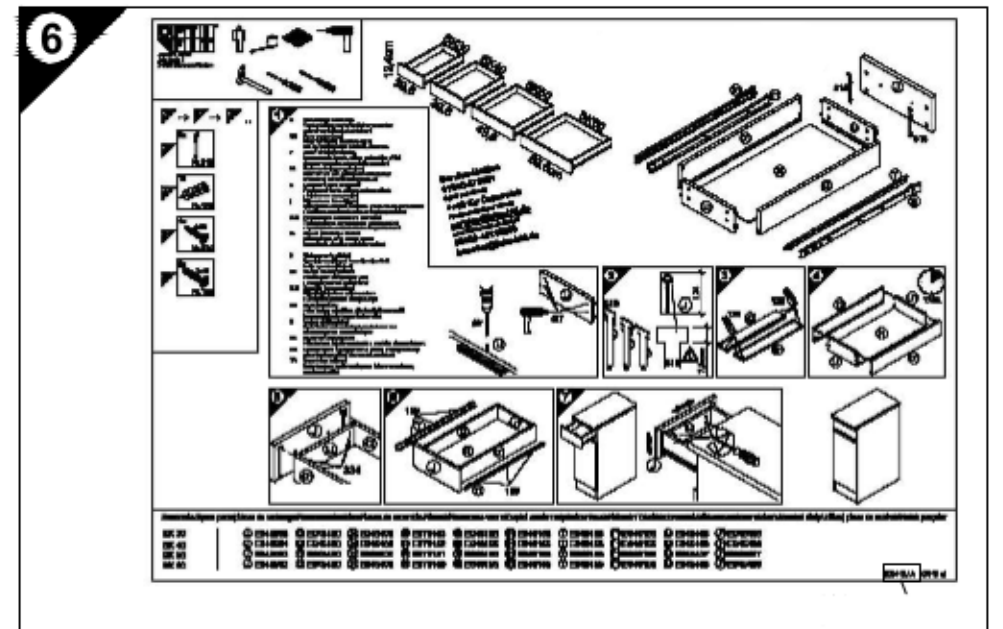
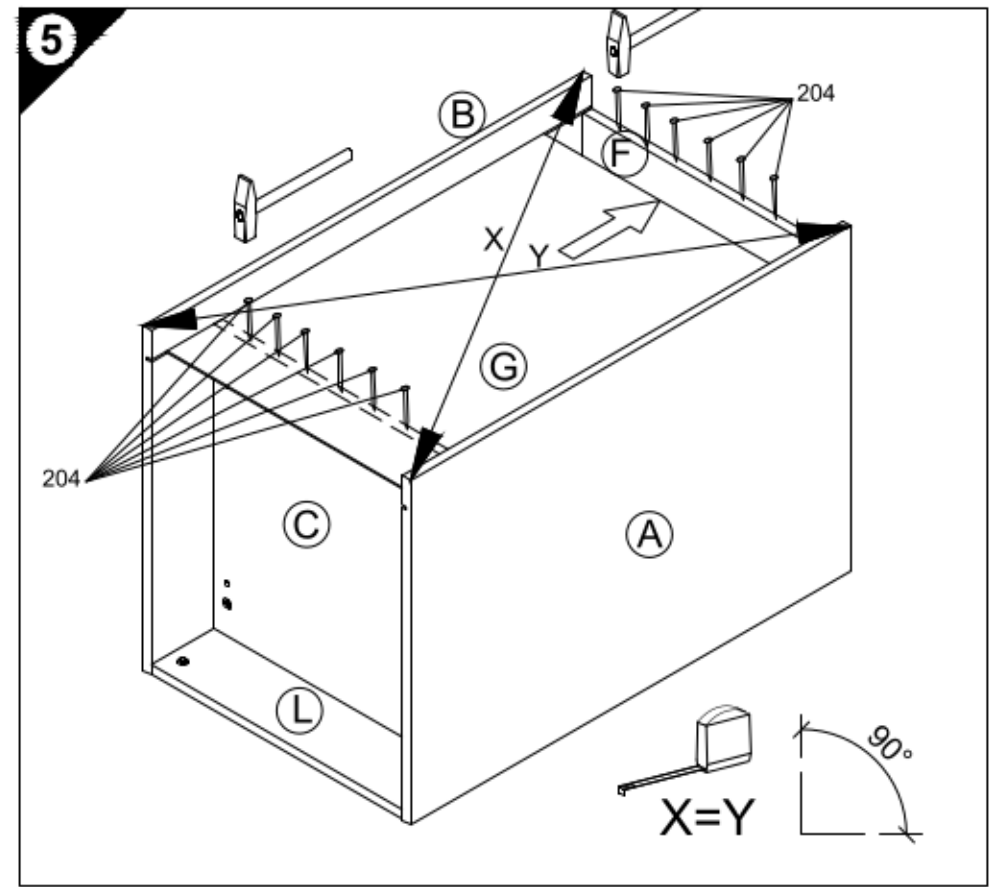
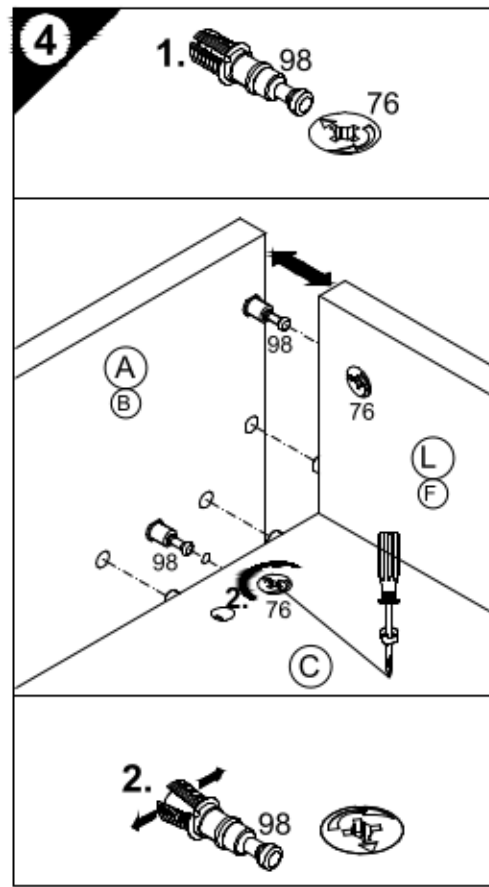
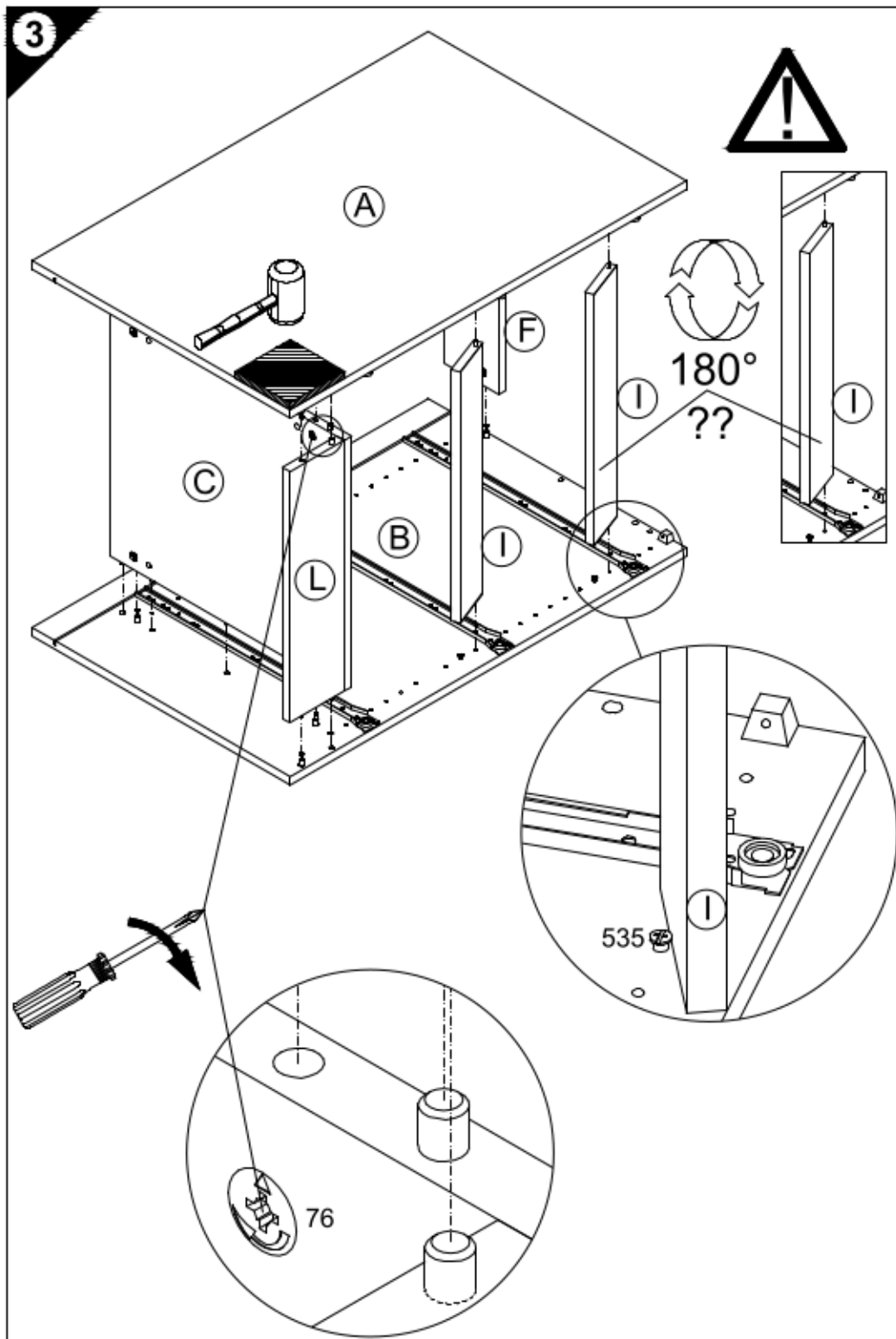
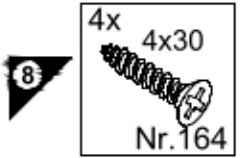
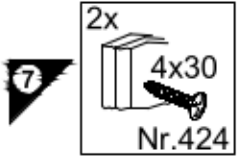
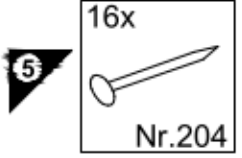

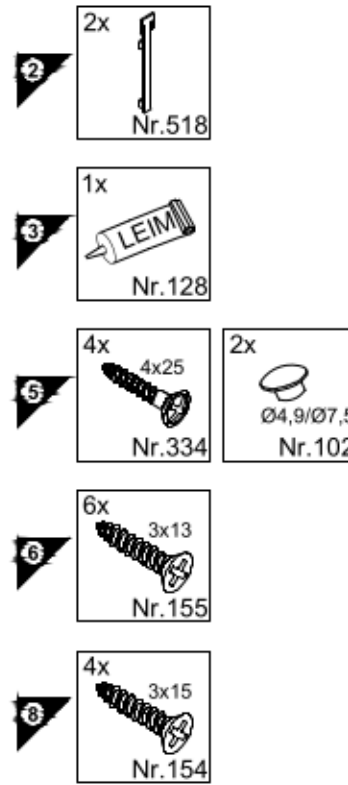
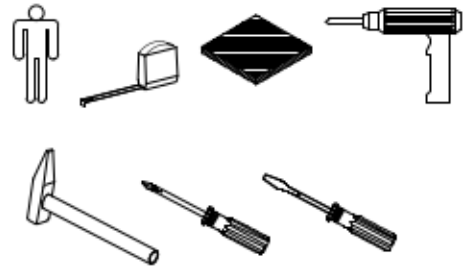

1

D Holzunterlage verwenden!
Front andrücken, scharfen Bohrer verwenden und mit wenig Druck durchbohren!

GB Use a wooden base!
Press front down, use sharp drill bit and, by applying slight pressure, drill a hole

F Utiliser un support en bois!
Appuyer sur la façade, utiliser un foret bien affûté et percer en appliquant une faible pression!

NL Houten onderlegger gebruiken!
Druk het front aan, gebruik een scherpe boor en oefen bij het boren weinig druk uit!

E Utilizar una base de madera!
Presionar el frente, utilizar una broca afilada y taladrar con poca presión!

I Utilizzare una base di legno!
Appoggiare la facciata, utilizzare una punta di trapano affilata e trapanare esercitando solo una leggera pressione!

RUS Использовать деревянную подложку!
Прижать фасад, использовать острое сверло и просверлить с незначительным давлением!

PL Używać podkładkę z drewna!
Docisnąć front, użyć ostrego wiertła i przewiercić, używając małej siły nacisku!

H Alkalmazzon fa alátét!
Nyomja le az előlapot, hasznájon éles fűrőt, és kis nyomással fúrja át!

CZ Použijte dřevěný podklad!
Přitlačte čelo, použijte ostrý vrták a provrtávejte pomocí malého tlaku!

SLO Uporabite leseno podlago!
Pritisnite ličnico ter z ostrim svedrom in z majhnim pritiskom izvrtajte luknjo!

FIN Käytä puualustaa!
Paina etulevy paikoilleen, käytä terävää poranterää ja poraa reikä vain kevyesti painamalla!

S Använd ett träunderlag!
Tryck fronten mot underlaget, använd vass borr och borra igenom med ett lätt tryck!

SK Použite drevený podklad!!
Přitlačte front, použijte ostrý vrták a prevrtávejte miernym tlakom!

RO suport de lemn! Împingeți frontul, utilizați un burghiu ascuțit și perforați exercitând doar o presiune redusă!

TR Ahşap taban kullanın!
Önden bastırın, keskin matkap ucu kullanın ve az basınç uygulayarak delin!

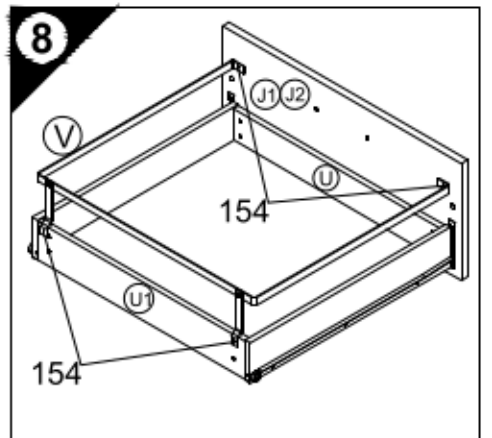
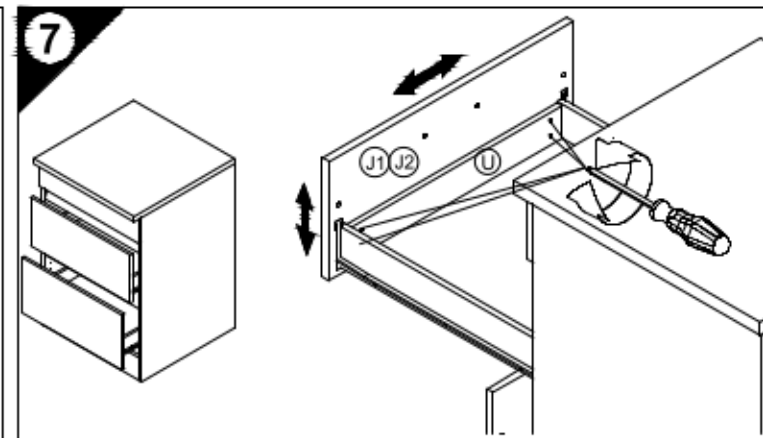
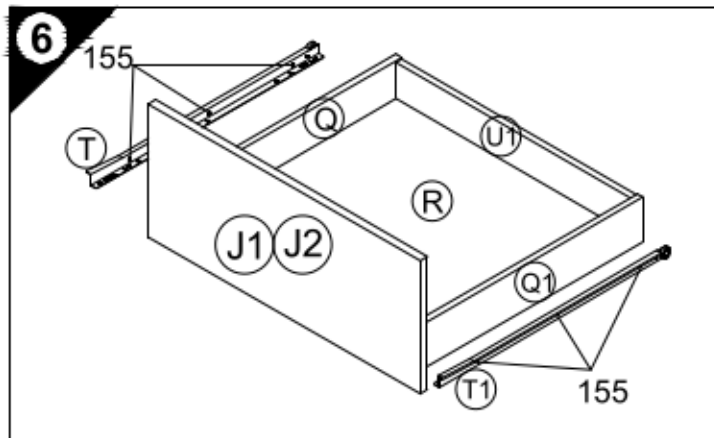
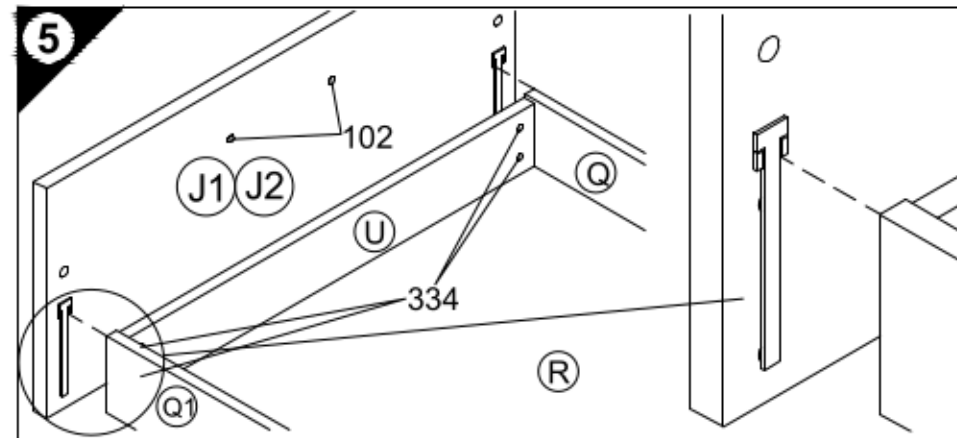
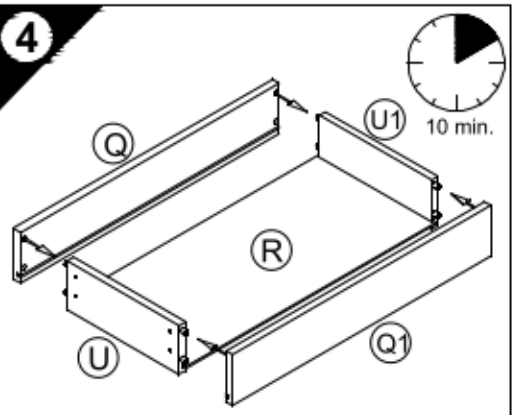
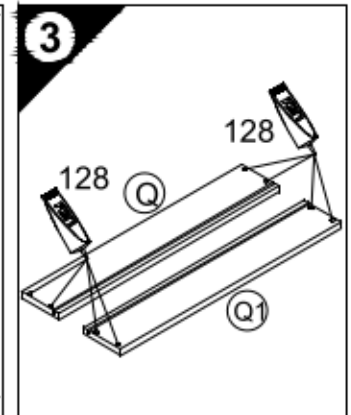
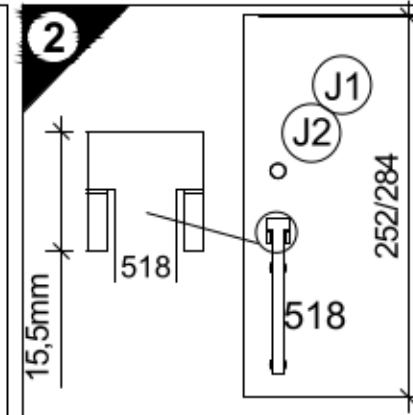
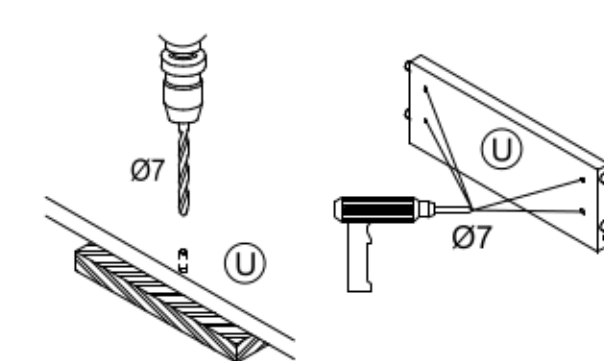
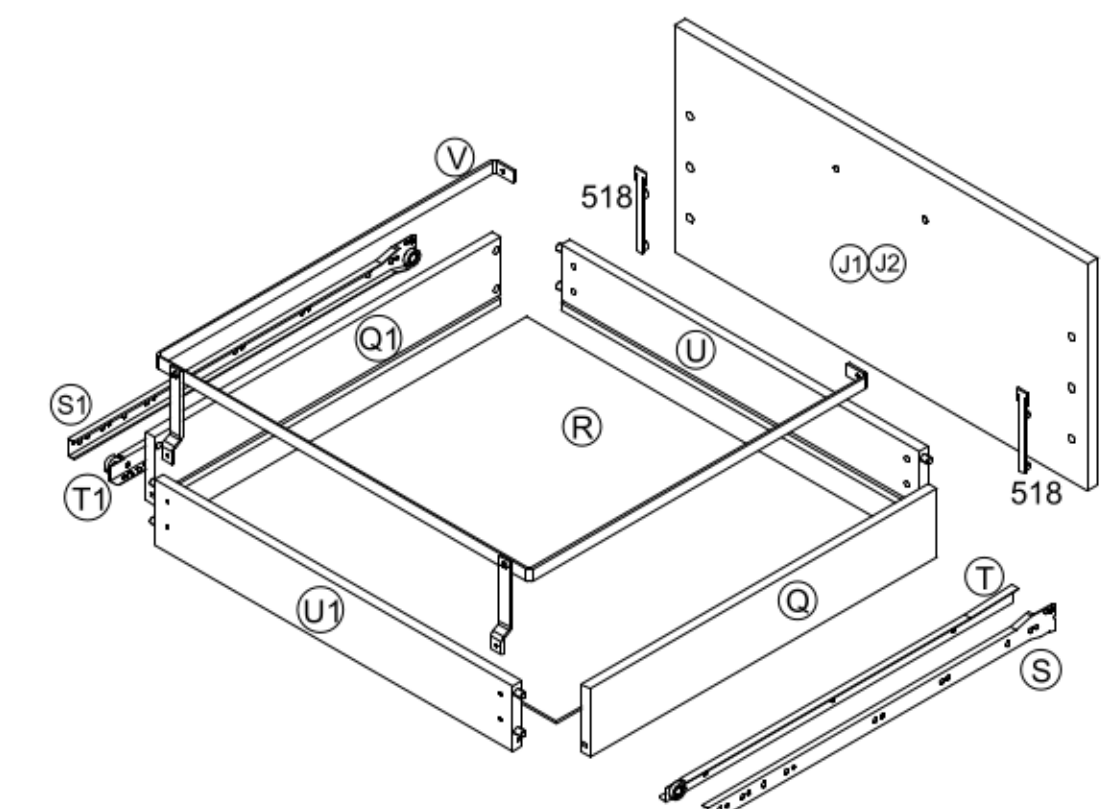
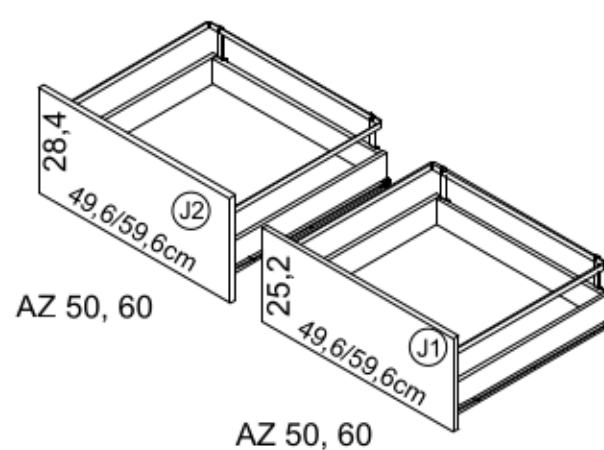
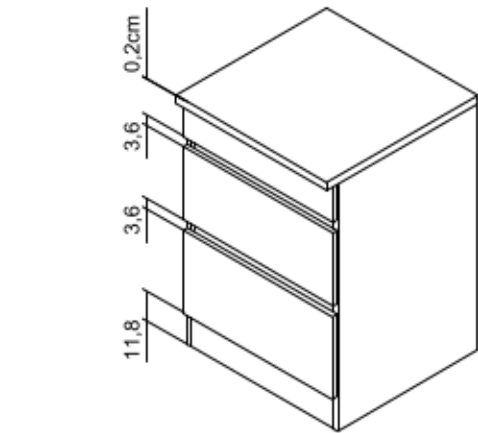

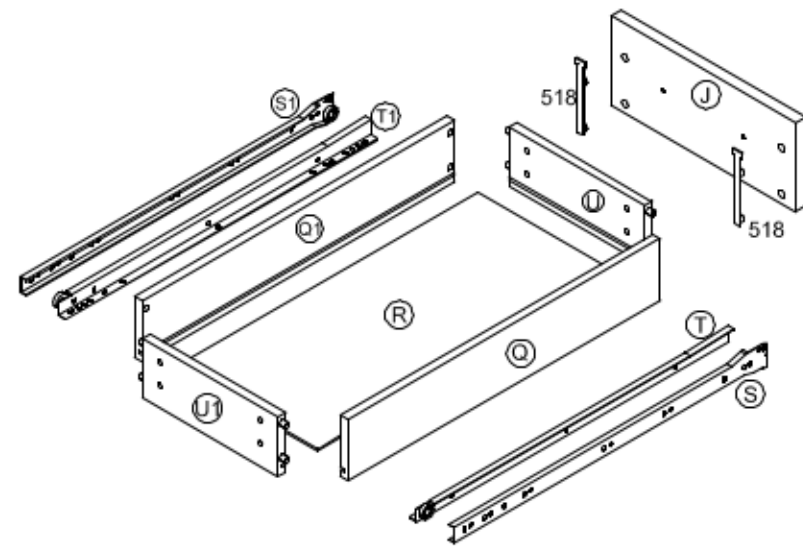
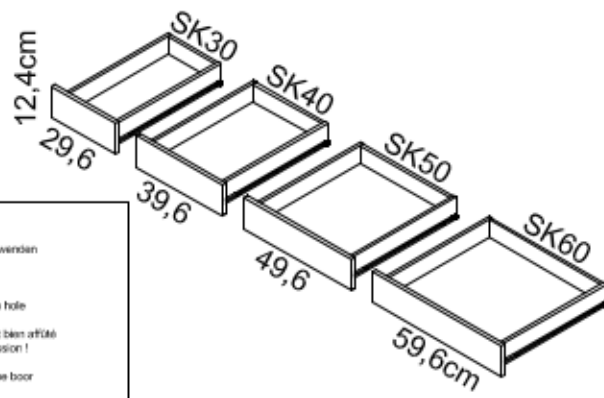
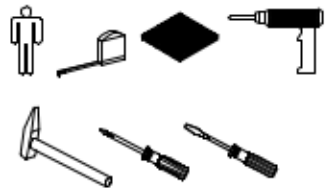

- 1 → 2 → 3 ...
- 2x Nr. 518
- 1x LEIM Nr. 128
- 4x 4x25 Nr. 334
- 6x 3x13 Nr. 155

1

D Holzunterlage verwenden!
Front andrücken, scharfen Bohrer verwenden und mit wenig Druck durchbohren!
GB Use a wooden base!
Press front down, use sharp drill bit and, by applying slight pressure, drill a hole.
F Utiliser un support en bois!
Appuyer sur la façade, utiliser un foret bien affilé et percer en appuyant une faible pression!
NL Houder onderliggen gebruiken!
Druk het front een, gebruik een scherpe boor en oefen bij het boren weinig druk uit!
E Utilizar una base de madera!
Presionar el frente, utilizar una broca afilada y taladrar con poca presión!
I Utilizzare una base di legno!
Appoggiare la facciata, utilizzare una punta di trapano affilata e trapanare esercitando solo una leggera pressione!
RUS Использовать деревянную подложку!
Прекать фасад, использовать острое сверло и проделать с незначительным давлением!
PL Używać podkładki z drewna!
Docisnąć front, użyć ostrych wiertła i prowadzić, używając małej siły nacisku!
H Alkalmazson fa alálat!
Nyomja le az előlapot, használjon éles fúró, és kis nyomással fúrja át!
CZ Použijte dřevěný podklad!
Přitlačte čelo, použijte ostrý vrták a provádějte pomocí malého tlaku!
SLO Uporabite leseno podlogo!
Prisnite ščeka ter z ostrim svedrom in z majhnim pritiskom izvrtajte lukrgo!
FIN Paine alustava puukalasin, käytä terävää poranterää ja poraa reikä vain kevyesti painamalla!
S Använd ett träunderlag!
Tryck fronten mot underlaget, använd vasst borr och borra igenom med ett litet tryck!
SK Použite drevený podklad!
Přitlačte front, použijte ostrý vrták a provádějte měkkým tlakem!
RO suport de lemn! Împingeți frontul, utilizați un burghiu ascuțit și perforați exercitând doar o presiune redusă!
TR Ahşap taban kullan!
Önden bastırın, keskin matkap ucu kullanın ve az basınç uygulayarak delin!

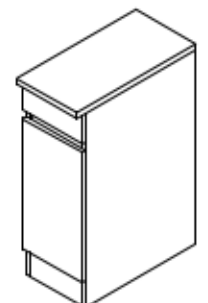
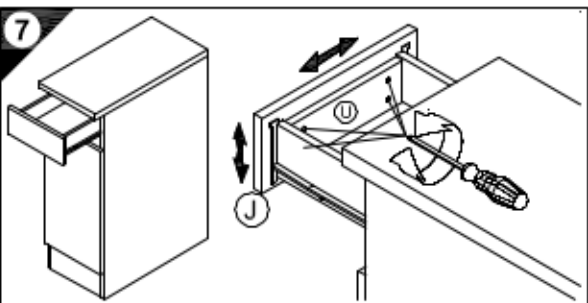
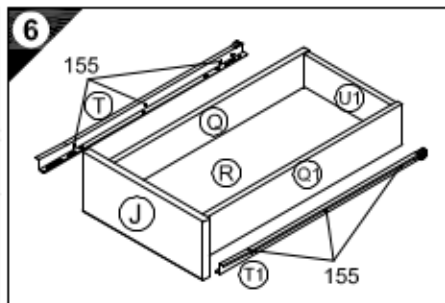
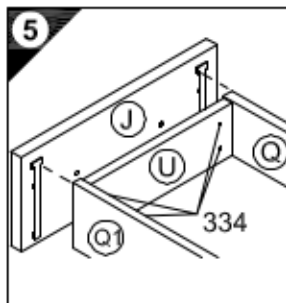
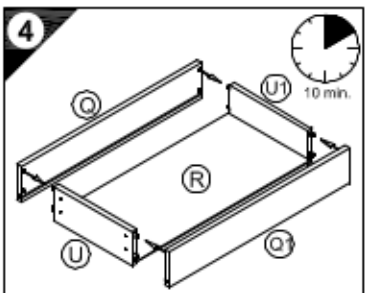
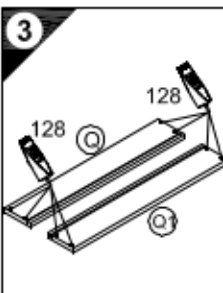
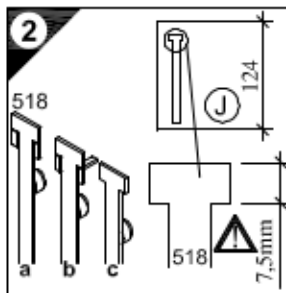
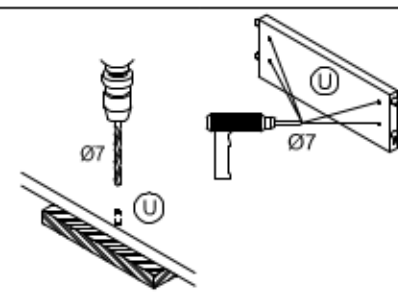

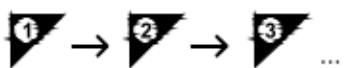
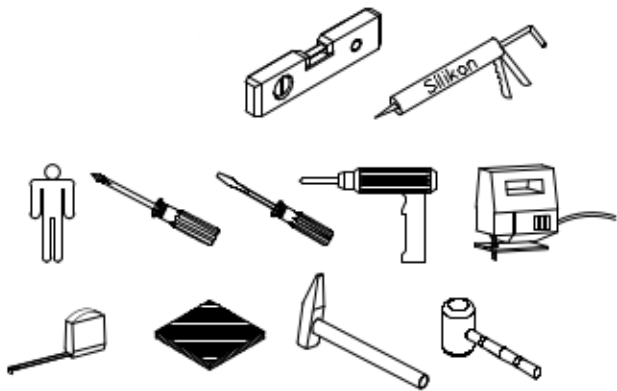

1

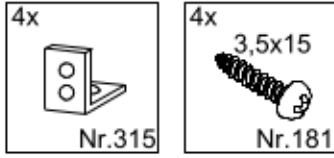
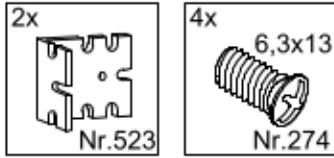
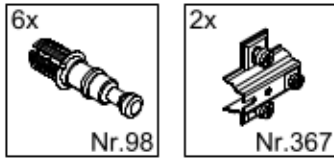

2

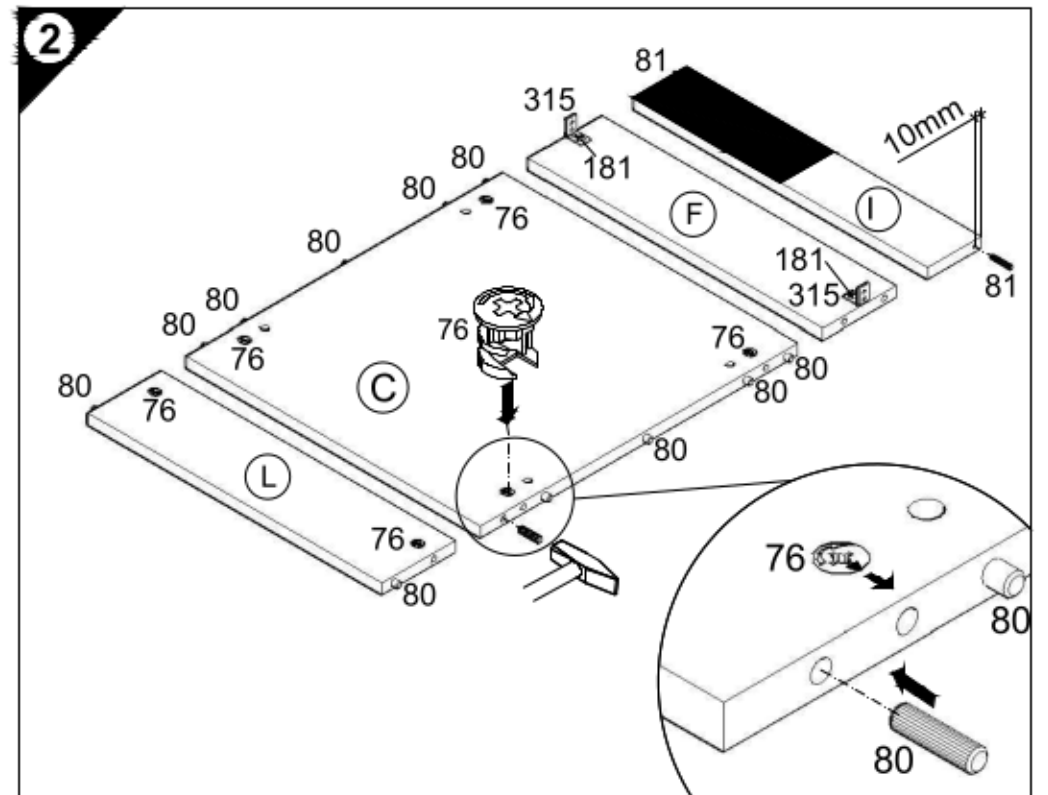
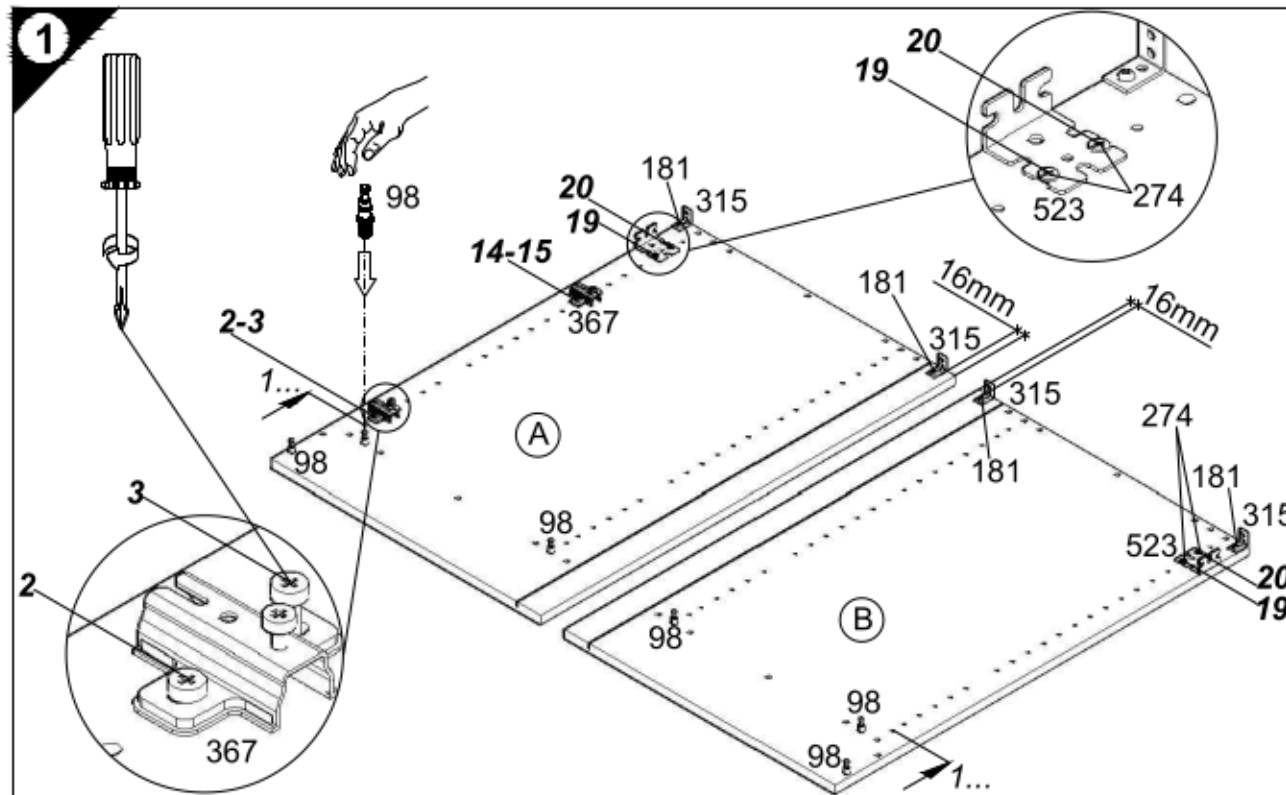
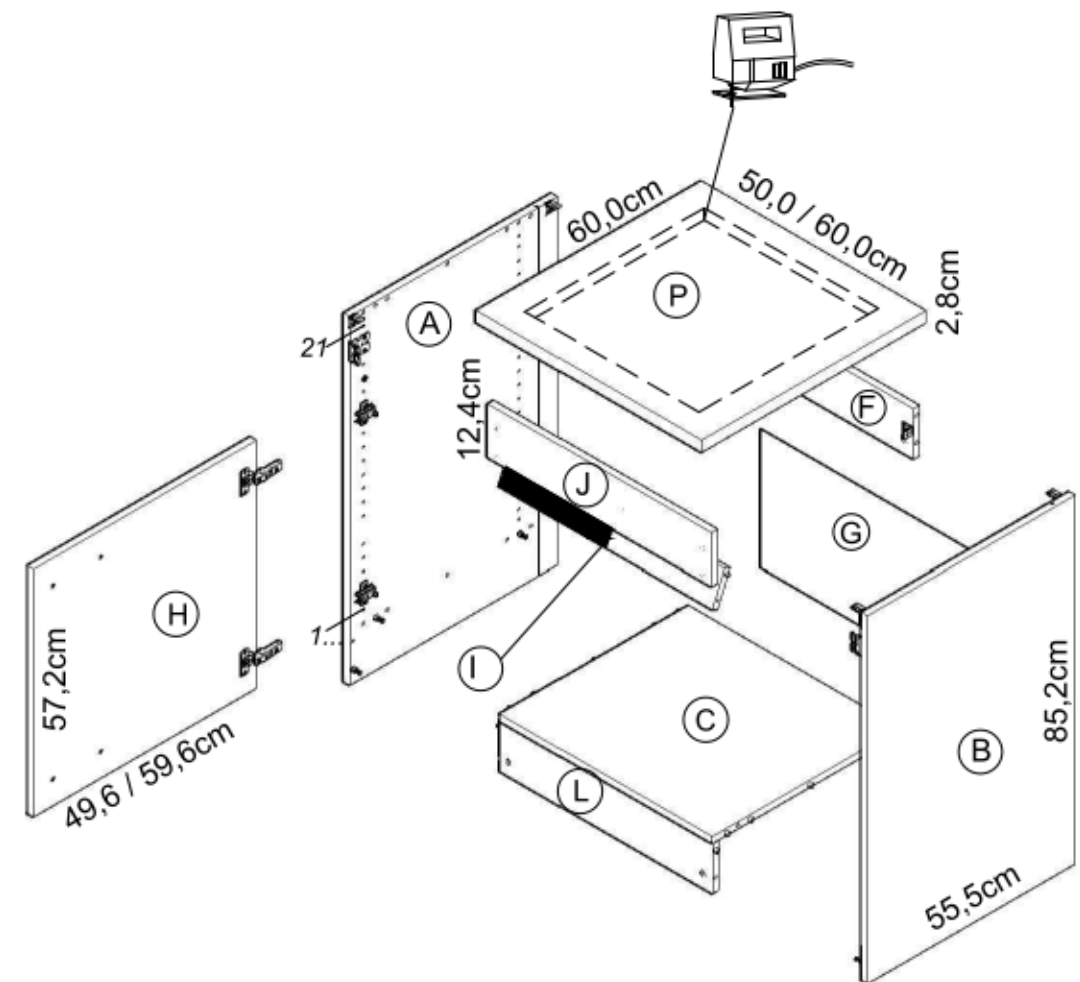
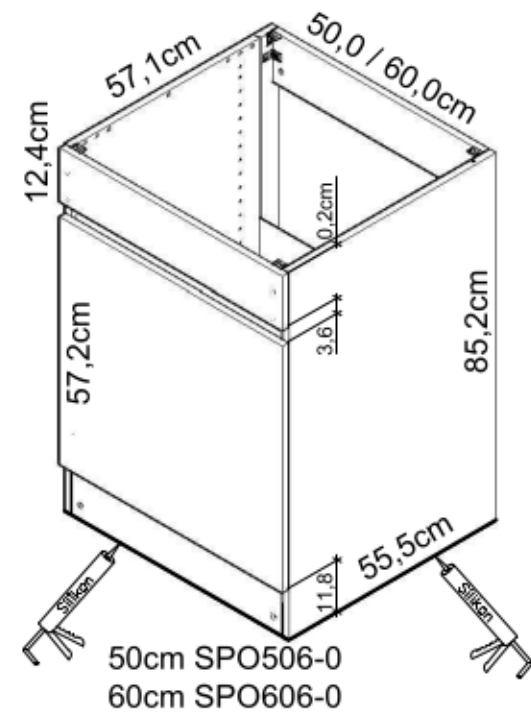
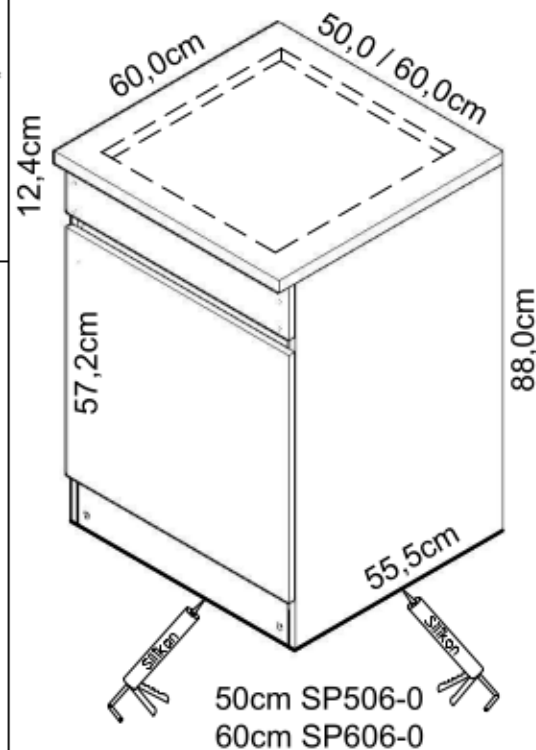
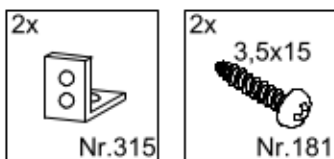
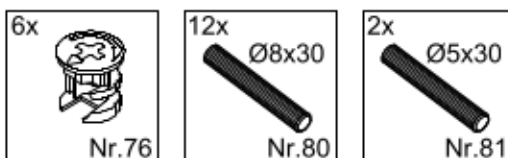

1 → 2 → 3 ...

- 5 16x
Nr.204
- 6 2x 4x15
Nr.336
- 7 2x 3,5x15
Nr.181
- 8 2x 4x30
Nr.424
- 9 4x 3,5x15
Nr.181
- 10 2x
Nr.365
- 6x
Ø4,9/Ø7,5
Nr.102
- 11 2x 6,3x11,5
Nr.535

