

UPUTSTVO ZA MONTIRANJE
ASSEMBLING INSTRUCTION
MONTAGEANLEITUNG
INSTRUCTIONS D'ASSEMBLAGE
INSTRUCCIONES DE MONTAJE

ISTRUZIONI PER L'INSTALLAZIONE
ИНСТРУКЦИЯ ПО МОНТАЖУ
MONTÁŽNÍ NÁVOD
ΟΔΗΓΙΕΣ ΣΥΝΑΡΜΟΛΟΓΗΣΗΣ
INSTRUCȚIUNI DE MONTAJ

ИНСТРУКЦИЯ ЗА МОНТАЖ
SZERELÉSI UTASÍTÁS
NAVODILA ZA MONTAŽO
UPUTE ZA MONTAŽU
UPUTSTVO ZA MONTIRANJE

УПАТСТВО ЗА МОНТИРАЊЕ
UDHËZIMET PËR MONTIM
INSTRUKCJA MONTAŻU
INSTRUÇÕES DE MONTAGEM
MONTAGE INSTRUCTIE

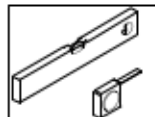
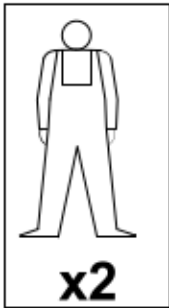

* **RS ME** Naznačeno vreme montaze važi za stručno obučena lica (profesionalne montažere)/**UK** The specified installation time applies to professionally trained persons (professional installers)/**DE AT CH** Die bezeichnete Zeit der Montage gilt für fachlich geschulte Personen (professionelle Monteure) / **FR CH** Le temps d'installation spécifique s'applique aux personnes formées professionnellement (installateurs professionnels) / **ES** El tiempo de instalación especificado se refiere a personas profesionalmente capacitadas (instaladores profesionales) / **IT CH** tempo di installazione indicato vale per le persone professionalmente preparate (installatori professionali) / **RUS** Приведённое время монтажа действительно для специально обученных лиц (профессиональных монтажников) / **CZ** Uvedená doba montáže se vztahuje na odborně způsobilé osoby (profesionální montér) / **EL** Ο αναφερόμενος χρόνος εγκατάστασης ισχύει για εκπαιδευμένα άτομα (επαγγελματίες εγκαταστάτες) / **RO** Timpul de instalare specificat se aplică persoanelor instruite profesional (instalatori profesioniști) / **BG** Посоченото време за монтаж се отнася за професионално обучени лица (професионални монтажници) / **HU** Az összeszerelés megjelölt ideje a szakképzett személyekre vonatkozik (hivatásos összeszerelők) / **SL** Navedeni čas namestitve (montaže) velja za strokovno usposobljene osebe (strokovne monterje) / **HR** Navedeno vrijeme montaže odnosi se na stručno osposobljene osobe (profesionalne montažere) / **BIH** Naznačeno vrijeme montaže važi za stručno obučena lica (profesionalne montažere) / **MK** Naznačeno vreme za montažu važi za stručno obučena lica (profesionalni montažeri) / **AL** Koha e specifikuar e instalimit zbatohet në rast të personave me trajnim profesional (instalues profesionistë) / **PL** Znacznony czas montażu dotyczy przeszkolonych zawodowo osób (profesjonalnych monterów) / **PT** O tempo de montagem indicado aplica-se a pessoas profissionalmente treinadas (instaladores profissionais) / **NL BE** De aangegeven installatietijd is geldig voor professioneel opgeleide personen (professionele installateurs).

RS ME PRE POČETKA MONTIRANJA OBAVEZNO PROČITAJTE UPUTSTVO ZA MONTAŽU / **UK** BEFORE STARTING, REFER TO THE ASSEMBLING ADVICE IN ANNEX / **DE AT CH** VOR DER MONTAGE BITTE BEILIEGENDE ANWEISUNGEN LESEN / **FR CH** AVANT LE DÉBUT DE L'ASSEMBLAGE, S'IL VOUS PLAÎT, LISEZ L'INSTRUCTION D'ASSEMBLAGE / **ES** ANTES DE EMPEZAR EL MONTAJE, LEER CUIDADOSAMENTE LAS INSTRUCCIONES DEL ANEXO / **IT CH** PRIMA DI INIZIARE L'INSTALLAZIONE SI RACCOMANDA DI LEGGERE LE ISTRUZIONI DI INSTALLAZIONE / **RUS** ДО НАЧАЛА МОНТАЖА ОЗНАКОМЬТЕСЬ С ИНСТРУКЦИЕЙ / **CZ** SEZNAMTE SE S NÁVODEM PŘED MONTÁŽÍ NÁBYTKU / **EL** ΠΡΙΝ ΞΕΚΙΝΗΣΕΤΕ ΤΗ ΣΥΝΑΡΜΟΛΟΓΗΣΗ, ΟΠΟΣΔΗΠΟΤΕ ΔΙΑΒΑΣΤΕ ΤΙΣ ΟΔΗΓΙΕΣ ΣΥΝΑΡΜΟΛΟΓΗΣΗΣ / **RO** ÎNAINTE DE ÎNCERPEREA MONTAJULUI ESTE OBLIGATORIE CITIREA INSTRUCȚIUNILOR / **BG** ПРЕДИ МОНТИРАЊЕ НЕ ЗАБРАВЯЙТЕ ДА СЪ ЧЕТЕ ИНСТРУКЦИИ ЗА МОНТАЖ / **HU** SZERELÉS ELŐTT OKVETLENÜL OLVASSA EL A HASZNÁLATI UTASÍTÁST / **SL** PRED ZAČETKOM MONTAŽE OBEZNO PREBERITE NAVODILA / **HR** PRIJE MONTAŽE UPOZNATI SE SA UPUTSTVOM / **BIH** PRE POČETKA MONTIRANJA OBAVEZNO PROČITAJTE UPUTSTVO ZA MONTAŽU / **MK** ПРЕД ПОЧЕТОК НА МОНТИРАЊЕ ЗАДОЛЖИТЕЛНО ДА СЕ ПРОЧИТА УПАТСТВОТО ЗА МОНТИРАЊЕ / **AL** PARA FILLIMIT TË MONTIMIT LEXONI PATJETËR UDHËZIMIN PËR MONTIM / **PL** PRZED ROZPOCZĘCIEM MONTAŻU PROSZĘ ZAPOZNAĆ SIĘ Z INSTRUKCJĄ / **PT** ANTES DE INICIAR A MONTAGEM, CERTIFIQUE-SE DE LER AS INSTRUÇÕES DE MONTAGEM / **NL BE** LEES DE MONTAGE INSTRUCTIE VOORDAT U MET DE INSTALLATIE BEGINT

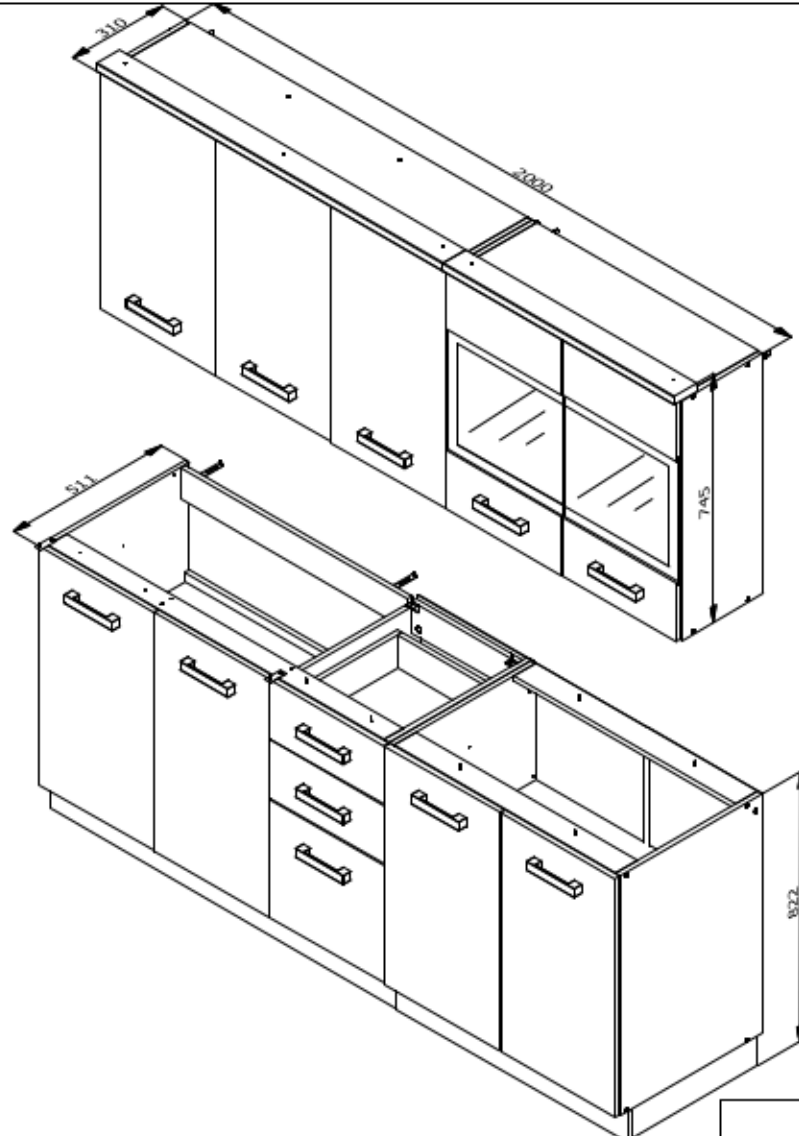
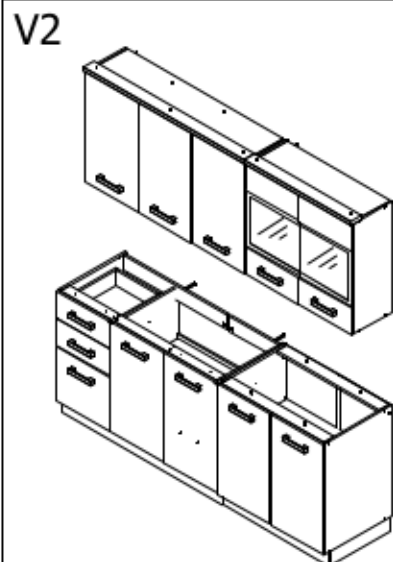
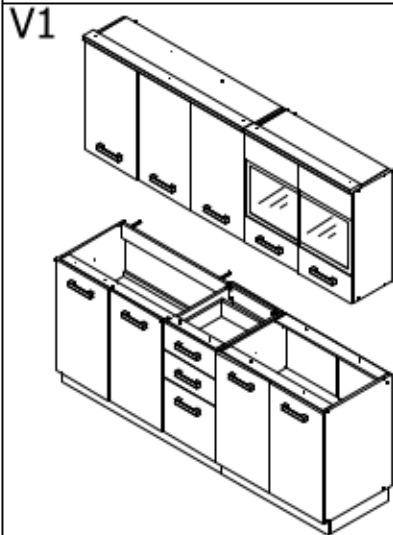

RS ME 1. Montažu obavljati na čistoj i mekoj podlozi (karton, tkanina...) 2. Da bi izbjegli oštećenja elemenata pridržavati se datih instrukcija. 3. Prilikom prijave reklamacije koristiti date oznake elemenata.	FR CH 1. Effectuer l'assemblage sur une surface propre et douce (carton, tissu...) 2. Afin d'éviter l'endommagement des éléments, respectez les instructions données. 3. Lors de l'application de réclamation, utiliser les désignations données des éléments.
DE AT CH 1. Die Montage soll auf sauberer, weicher Fläche durchgeführt werden (Karton, Stoff) 2. Um die Beschädigung der Elemente zu vermeiden, befolgen Sie bitte die angegebenen Instruktionen 3. Bei Reklamationsmeldungen benutzen Sie bitte die angegebenen Kennzeichen der Elemente	UK 1. Assembly of the product should be done on a clean and soft surface (cardboard, fabric) 2. To prevent damage of the product, it is necessary to adhere to the assembly instructions 3. While reporting defective products, please quote codes in manual
ES 1. Realizar el montaje sobre una superficie limpia y suave (cartón, paño) 2. Para evitar daños del producto, atenerse a las instrucciones de montaje 3. Para reportar productos defectuosos, refiérase por favor a los códigos del manual	IT CH 1. Eseguire l'installazione su una base morbida (cartone, tessuto). 2. Seguire le istruzioni per evitare di causare danni agli elementi. 3. In caso della presentazione di reclamo si utilizzano relative indicazioni degli elementi.
RO 1. Montarea se efectueaza pe o suprafata moale și curată (carton, material...) 2. Respectați instrucțiunile pentru a evita deteriorarea pieselor 3. La transmiterea reclamațiilor a se folosi inscripțiile date ale pieselor	CZ SK 1. Montáž provádět na čistém a měkkém podkladu (lepenka, látka) 2. Dodržujte přiložené instrukce, abyste předešli poškození součástí 3. Při reklamaci používejte přiložené označení element
EL 1. Η συναρμολόγηση του προϊόντος πρέπει να γίνει σε καθαρή και μαλακή επιφάνεια (χαρτόνι, ύφασμα). 2. Για να μην φθαρούν τα στοιχεία, συμμορφωθείτε με τις οδηγίες που παρέχονται. 3. Κατά τη δήλωση ελαττωματικού προϊόντος, αναφέρετε τους κώδικες των στοιχείων όπως αναφέρονται στο εγχειρίδιο.	RUS BLR 1. Монтаж изделия выполнять на чистой и мягкой поверхности (картон, ткань) 2. Для предотвращения порчи изделий необходимо придерживаться правил монтажа 3. В случае предъявления претензии использовать данные обозначения элементов.
BG 1. Монтажът трябва да бъде извършен върху чиста и мека основа /karton, тъкан/ 2. За да избегнете оцетяване на елементи, спазвайте дадените инструкции 3. При наличие на reclamaция, използвайте дадените кодове на елементи	HU 1. A szerelés tisztaság és puha felületen (karton, anyag) kell végrehajtani. 2. Károsodásnak elkerülése érdekében, tartsa be a megadott utasításokat. 3. Reklamáció esetén hivatkozzon a bútör alkatrészein megadott jelekre.
SL 1. Montažo opravimo na čisti in mehki podlogi (karton, tkanina) 2. Da bi se izognili poškodbam elementov, upoštevajte navodila. 3. Pri reklamaciji uporabimo oznake elementov	BIH HR 1. Montažu obavljati na čistoj i mekoj podlozi (karton, tkanina) 2. Da bi izbjegli oštećenja elemenata pridržavati se datih instrukcija 3. Prilikom prijave reklamacije koristiti date oznake elemenata
MK 1. Монтажа да се врши на чиста и мека подлога (karton, ткаенина) 2. За да се избегне оштетување на елементите придржувајте се на дадените инструкции 3. За пријава на рекламиции користете ги дадените ознаки на елементите	AL 1. Montimi të bëhet në sipërfaqe të pastër dhe të butë (karton, pëlthurë) 2. Që t'u shmangeni dëmtimit të elementeve, përmbahuni instrukcioneve të dhëna 3. Me rastin e reklamimit përdorni shenjat e dhëna të elementit
PL 1. Montować należy na czystej i miękkiej powierzchni (karton, tkanina) 2. Aby uniknąć uszkodzenia elementów należy postępować ściśle według instrukcji. 3. Przy zgłaszaniu reklamacji należy posługiwać się załączonymi oznaczeniami elementów.	HR 1. Pažljivo pročitajte upute za montažu 2. Pripremite sve dijelove namještaja 3. Prikupite i provjerite okove za montažu 4. Pripremite potreban alat 5. Pripremite prostor za montažu 6. Počnite montirati 7. Sačuvajte ove ove upute 8. Proizvod je namjenjen isključivo za kućnu uporabu
PT 1. A montagem deve ser feita em uma superfície limpa e macia (papelão, tecido...) 2. Para evitar danos nos elementos, siga as instruções fornecidas. 3. Durante a apresentação de reclamação usar os rótulos dos elementos fornecidos.	
NL BE 1. De installatie moet worden uitgevoerd op een schoon en zacht oppervlak (karton, stof...) 2. Volg de gegeven instructies om schade aan de elementen te voorkomen. 3. Gebruik bij het melden van een klacht de gegeven elementlabels.	

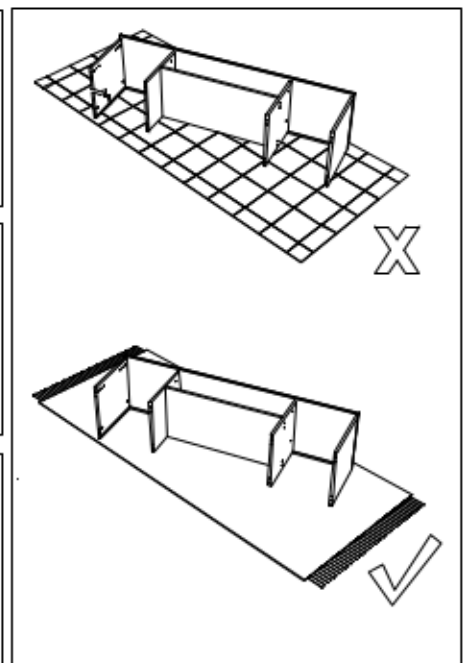
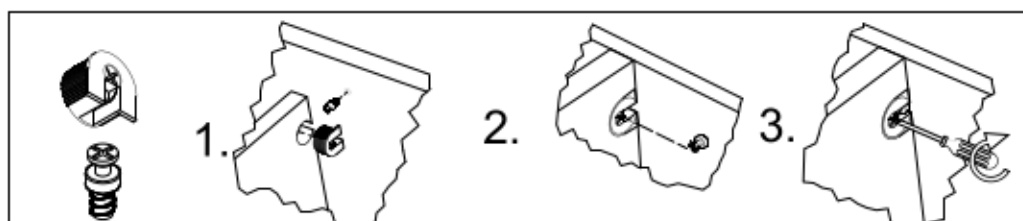
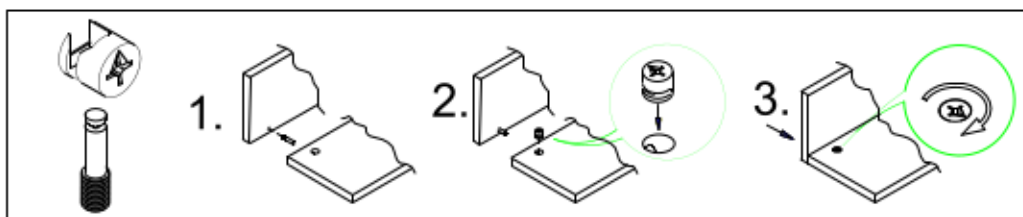
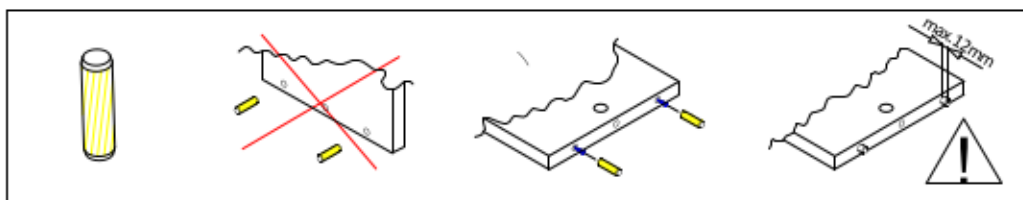

A	Ø8x30	B		C		D		E	Ø7x50	F	1.6 x 25	G		H		I	L=680mm	J	4x16
x51		x4		x24		x18		x43		x106		x2		x2		x1		x72	
K	Ø10x60	L	6x60	M		N		O	4x35	P		Q	4x30	R		S		T	
x4		x4		x1		x18		x5		x4		x26		x12		x2		x18	
U	4x30	V		W		X	3x25	Y	Ø7	Z	Ø8	Aa	Ø8x50	Ab		Ac		Ad	Ø6.3x13
x8		x4		x5		x11		x(5+4)		x6		x1		x4		x2		x8	
Ae		Af		Ag		Ah		Ai	3.5x16	Aj		Ak		Al		Am			
x9		x6		x10		x4		x12		x6		x4		x2					

1

A x 2	Aa x 1	Ag x 2
Ø8x30	Ø8x50	

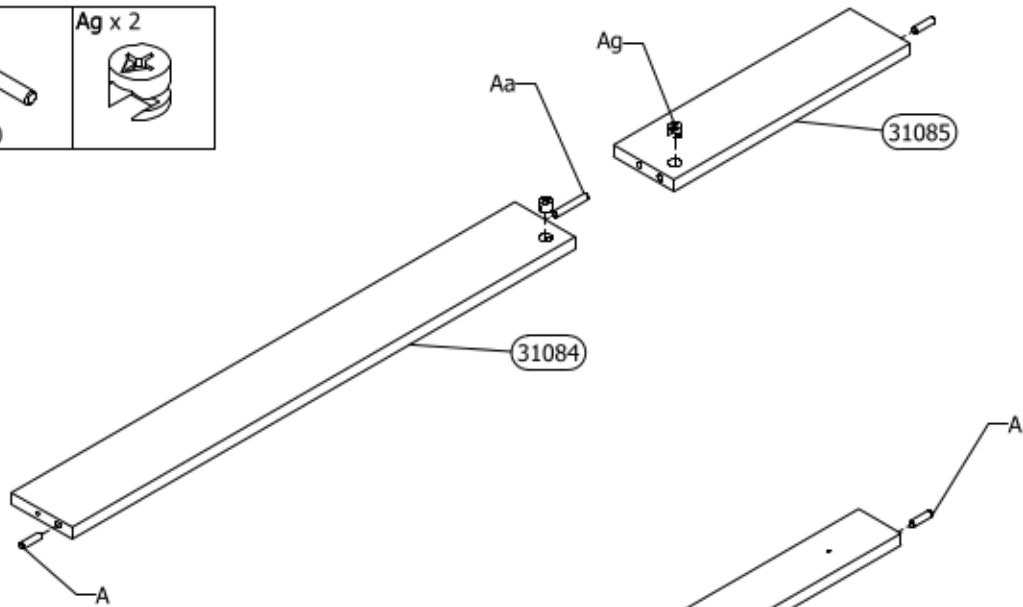

2

A x 2
Ø8x30

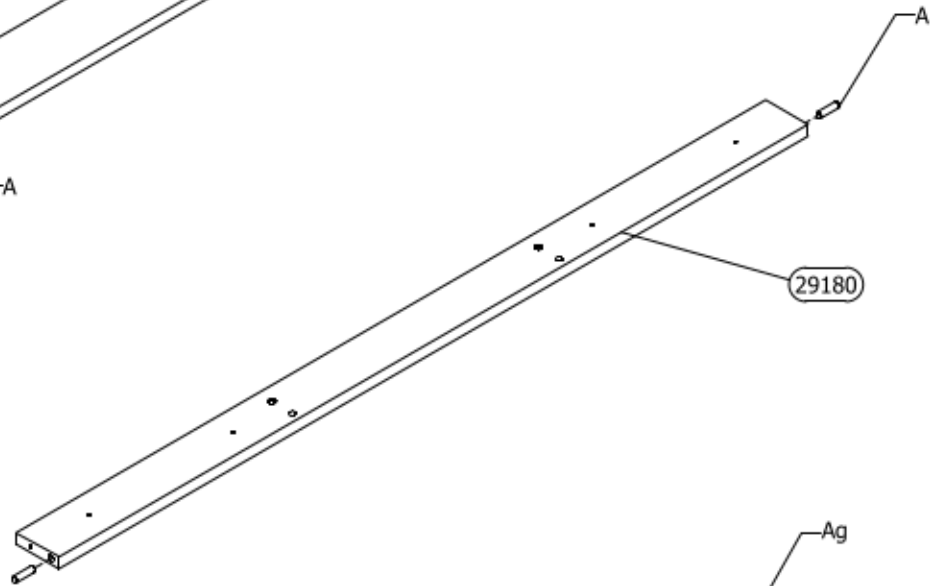

3

Ag x 4

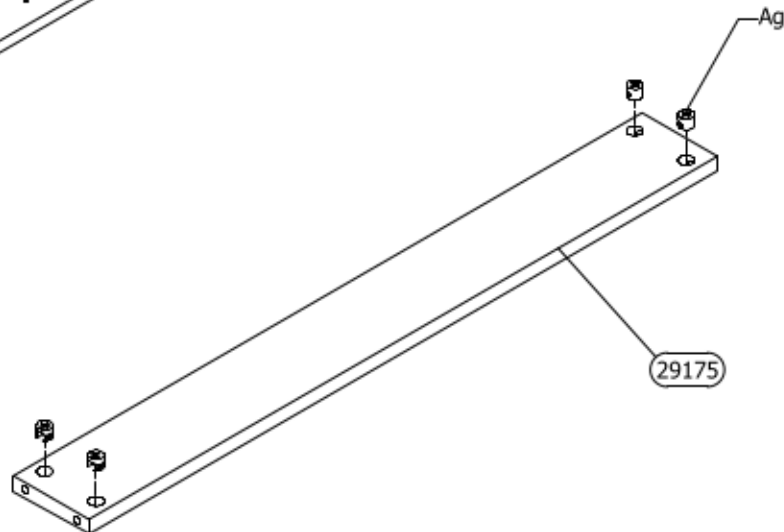

4

Ac x 2



Ad x 4



D x 2

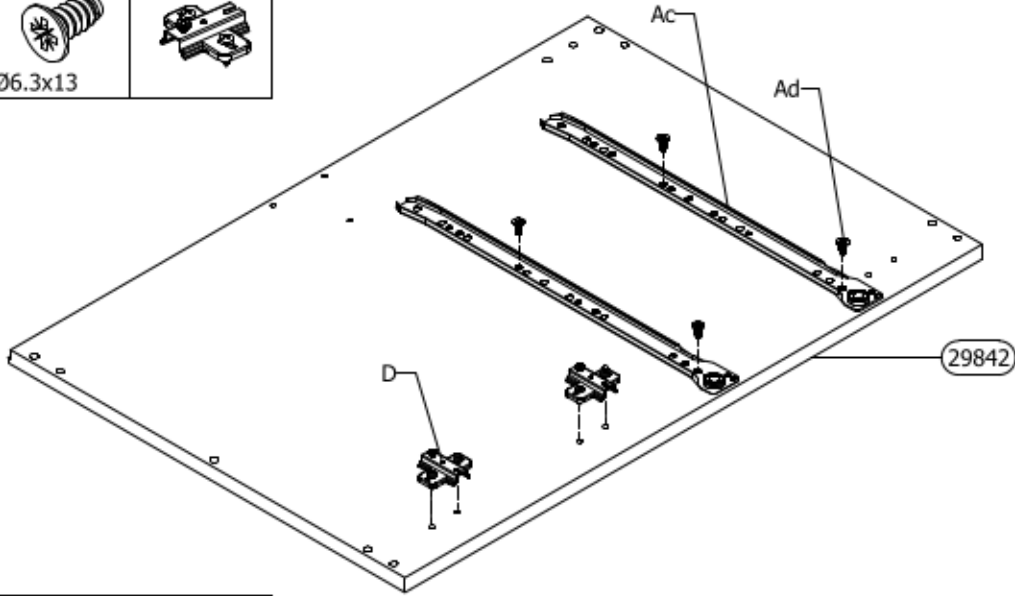

5

A x 3



Ac x 2



Ad x 4

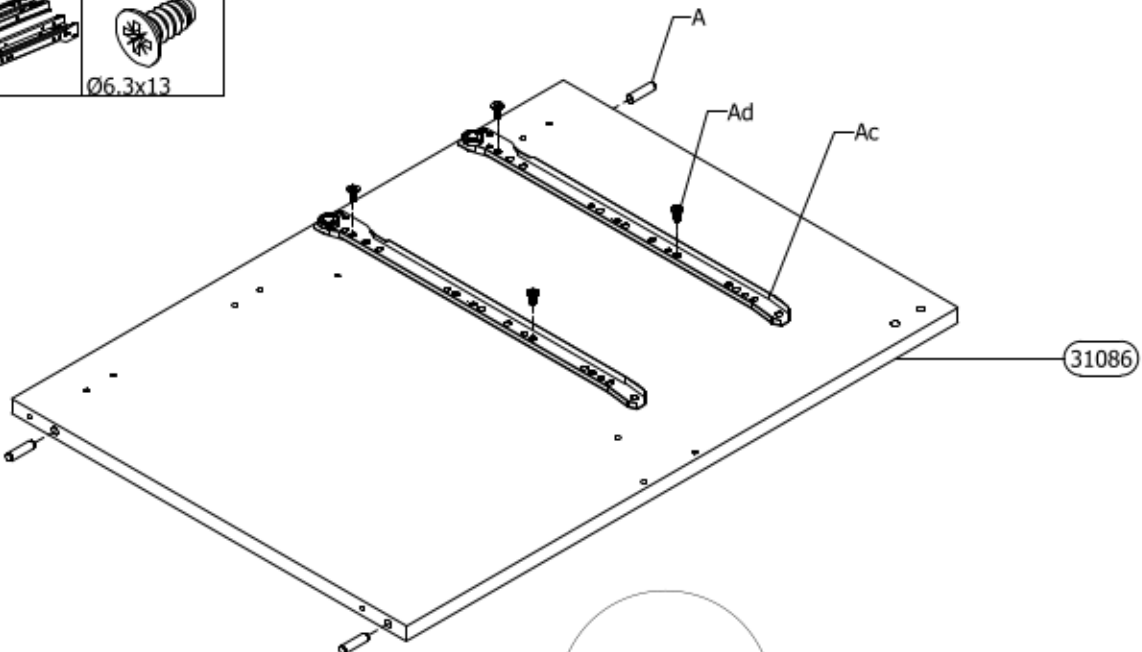

6

C x 2



Ab x 2



Al x 2

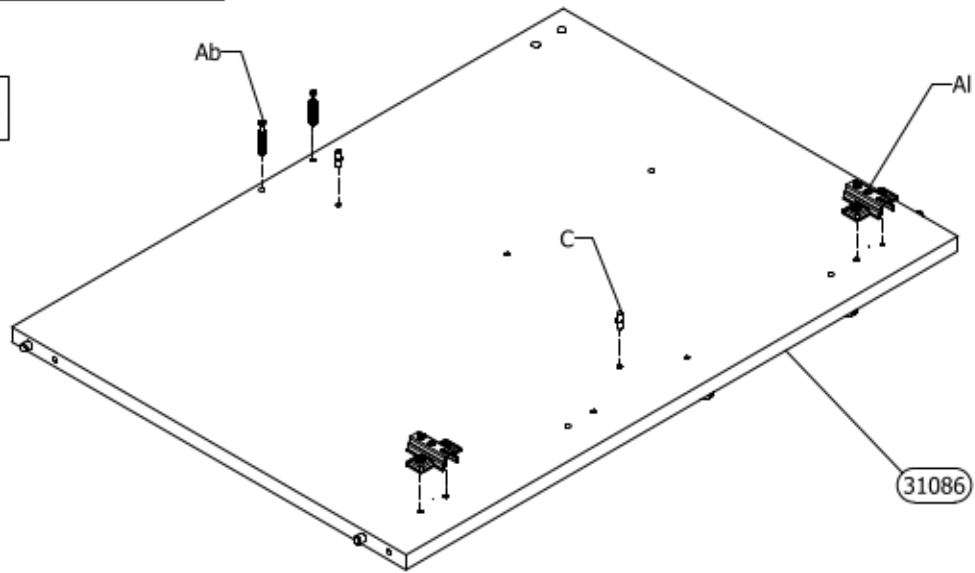
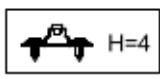

7 A x 6
Ø8x30

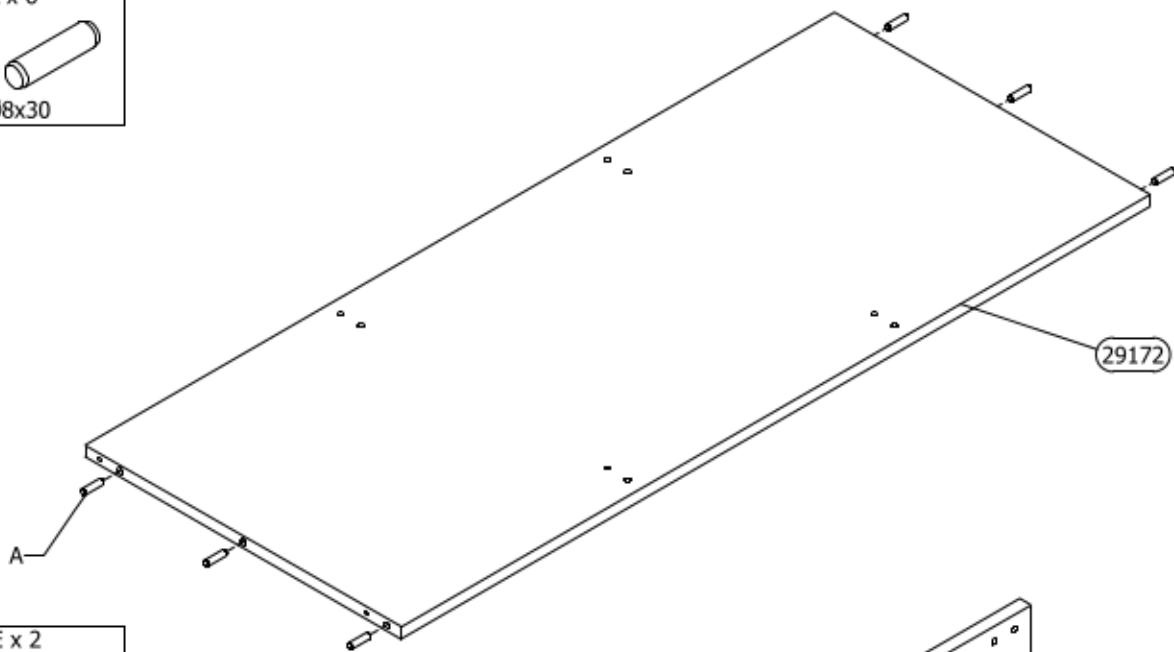

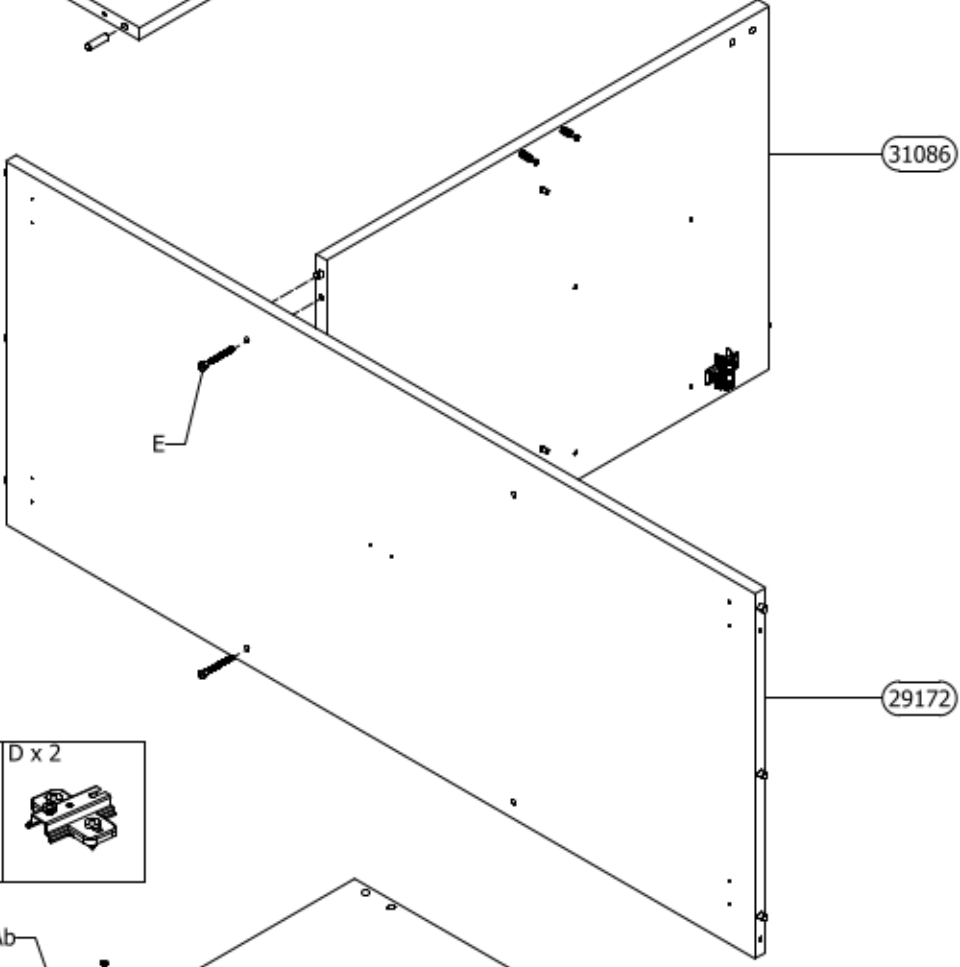

8 E x 2
Ø7x50



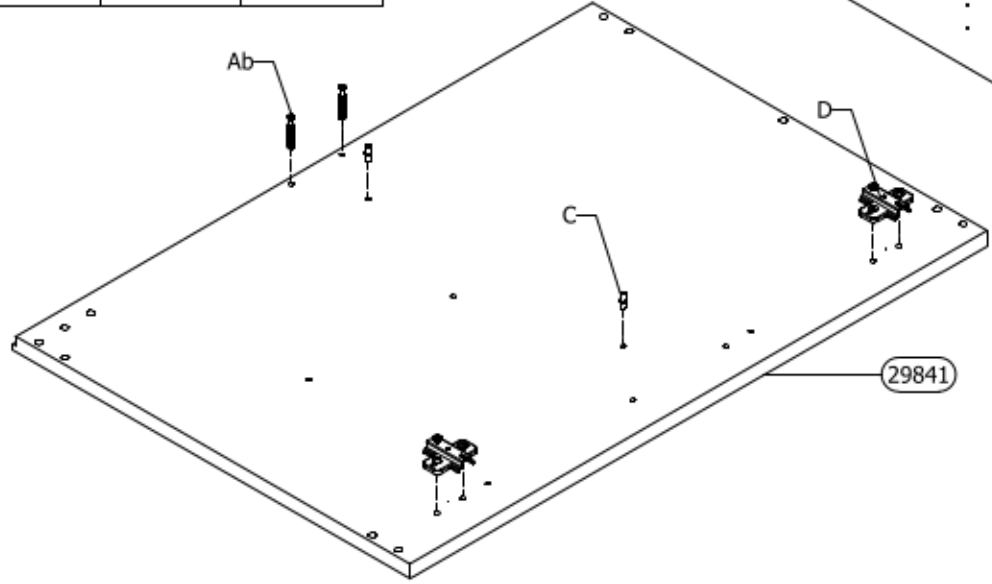



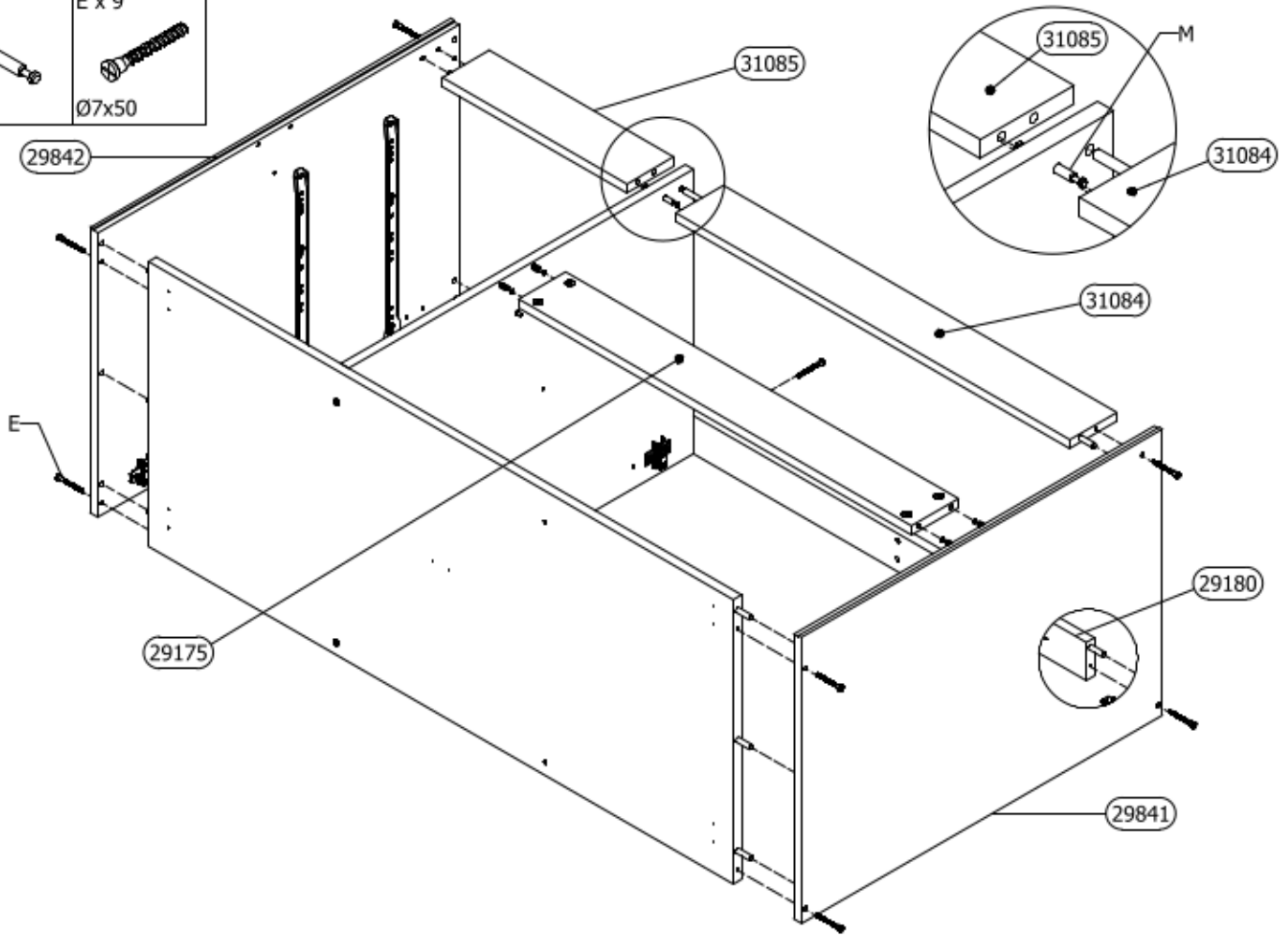

9 C x 2 Ab x 2 D x 2





- 10
- | | |
|--|--|
| M x 1 | E x 9 |
|  |  |
| | Ø7x50 |

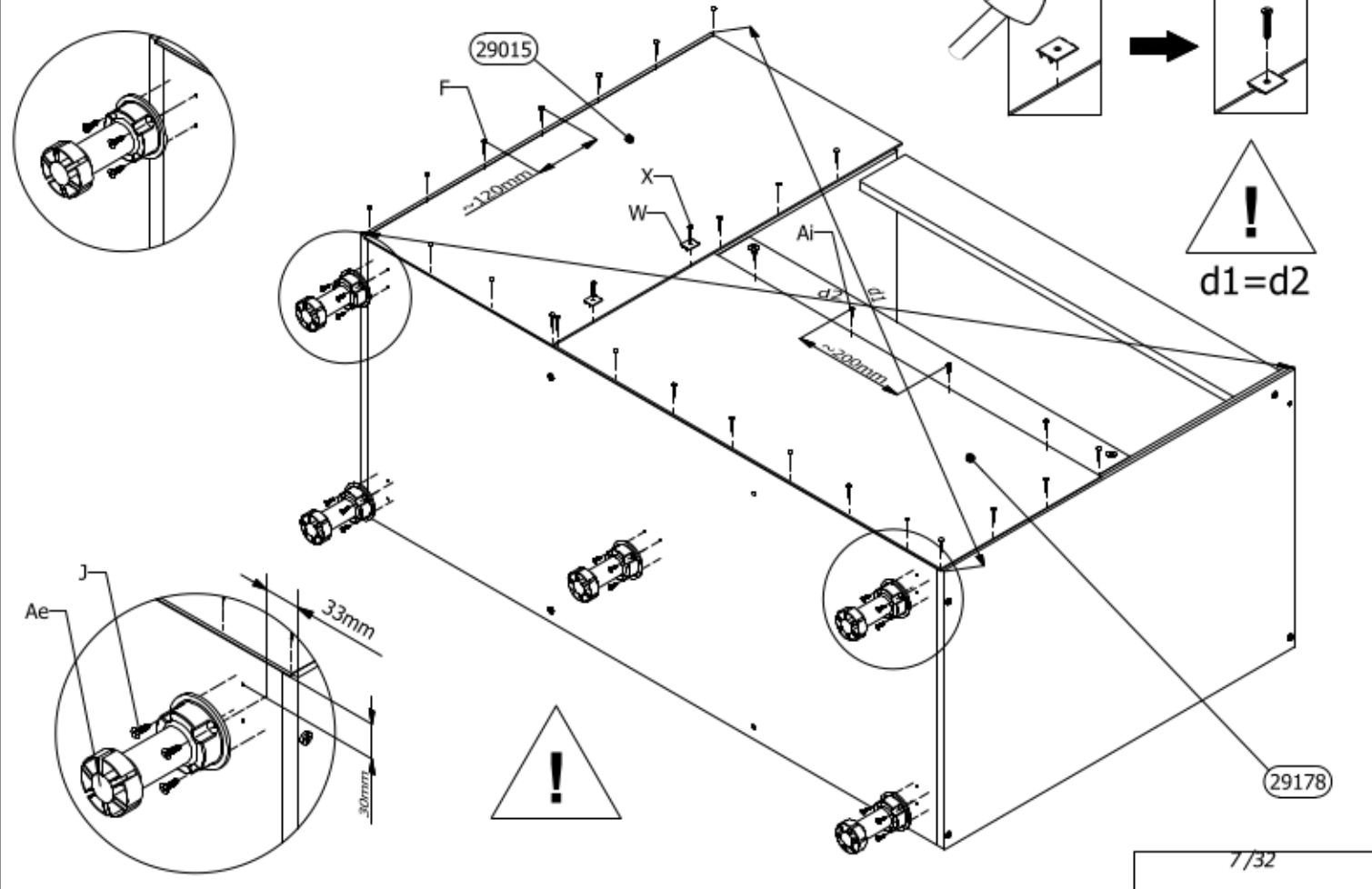

- 11
- | | | | | | |
|---|---|---|---|---|---|
| Ae x 5 | J x 20 | Ai x 4 | W x 2 | X x 2 | F x 24 |
|  |  |  |  |  |  |
| | 4x16 | 3.5x16 | | 3x25 | 1.6 x 25 |



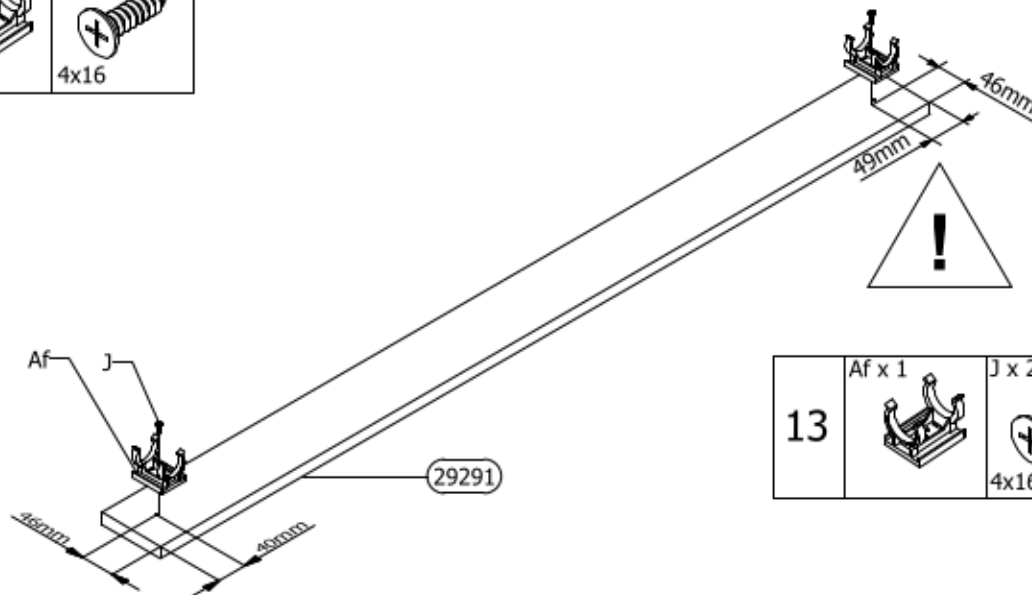

12

Af x 2	J x 2
	
	4x16





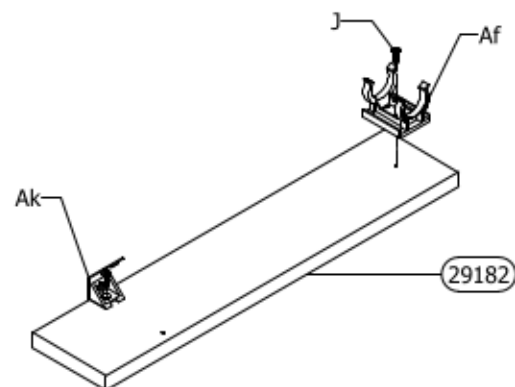

13

Af x 1	J x 2	Ak x 1
		
	4x16	



14

J x 6	Ak x 2	G x 2	H x 2
			
4x16			

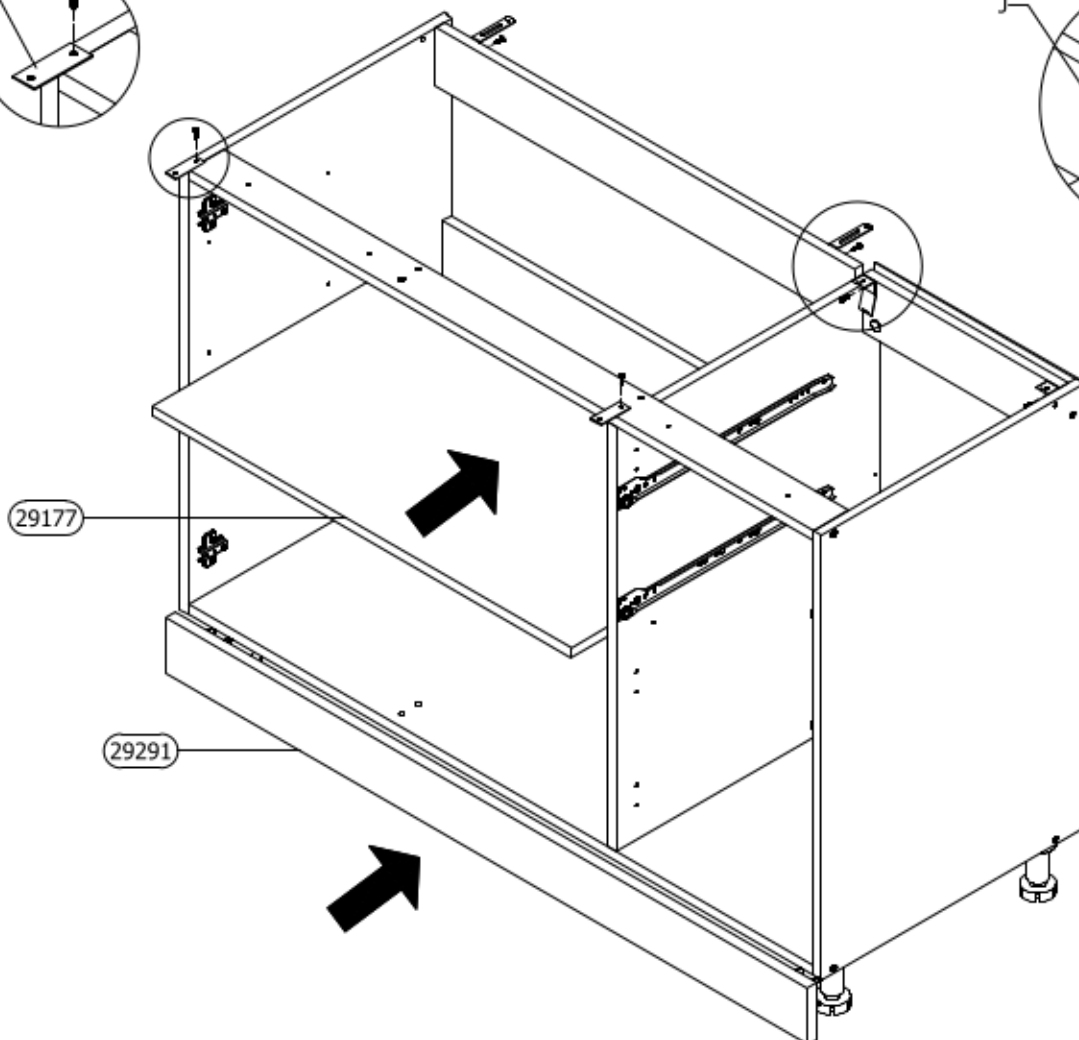
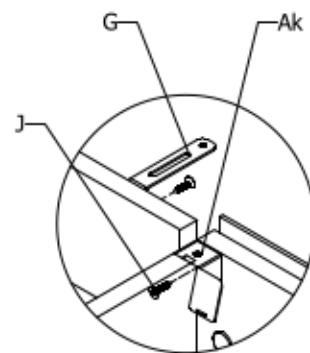
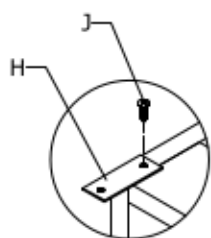

15

J x 5



4x16

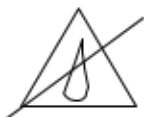
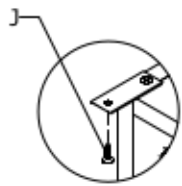

29182

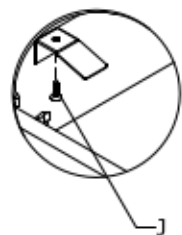

silikon

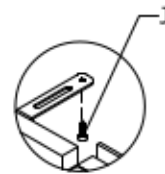
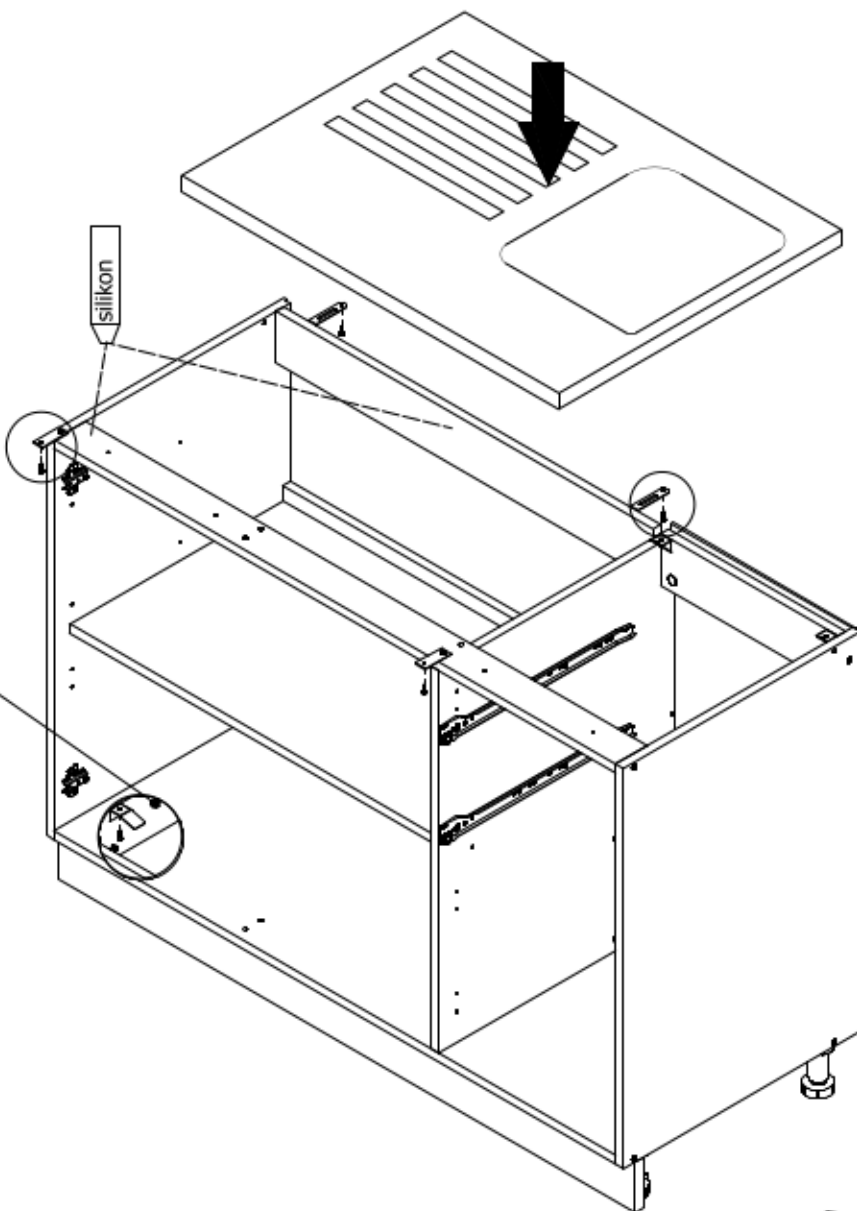

16

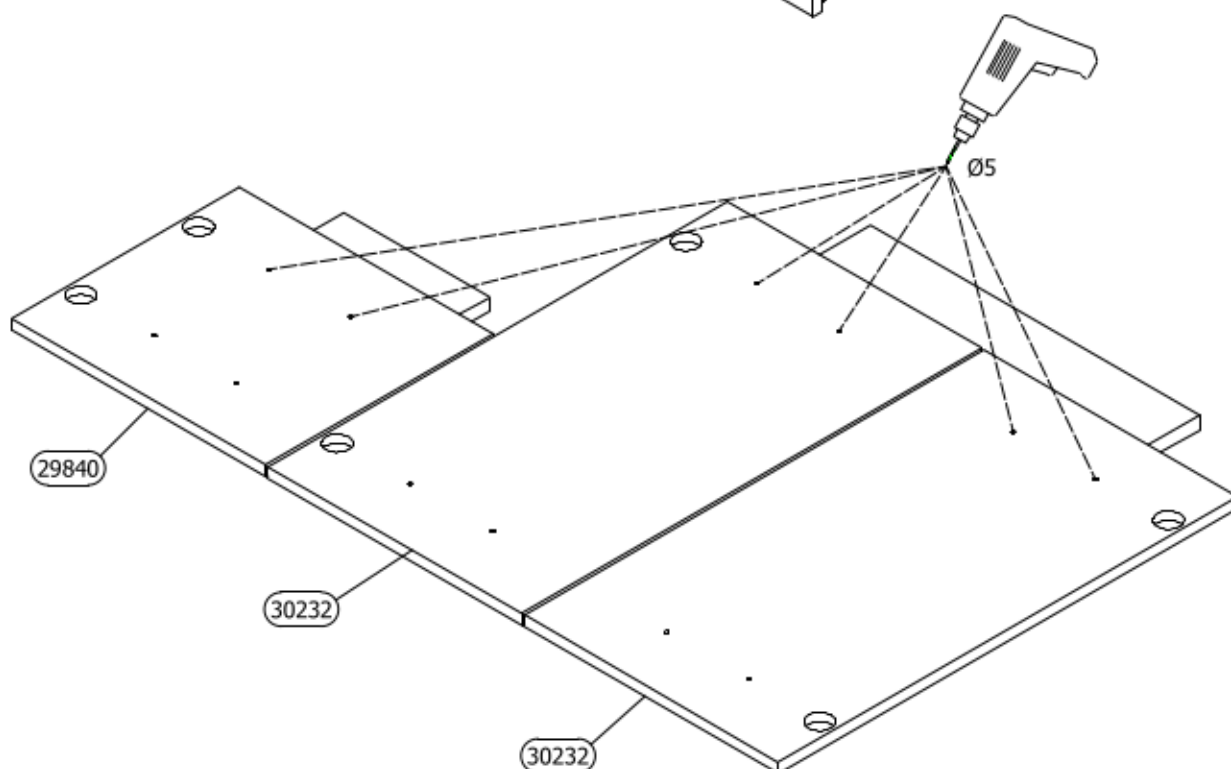

29840

30232

30232

17

N x 2

Q x 2

R x 1



4x30

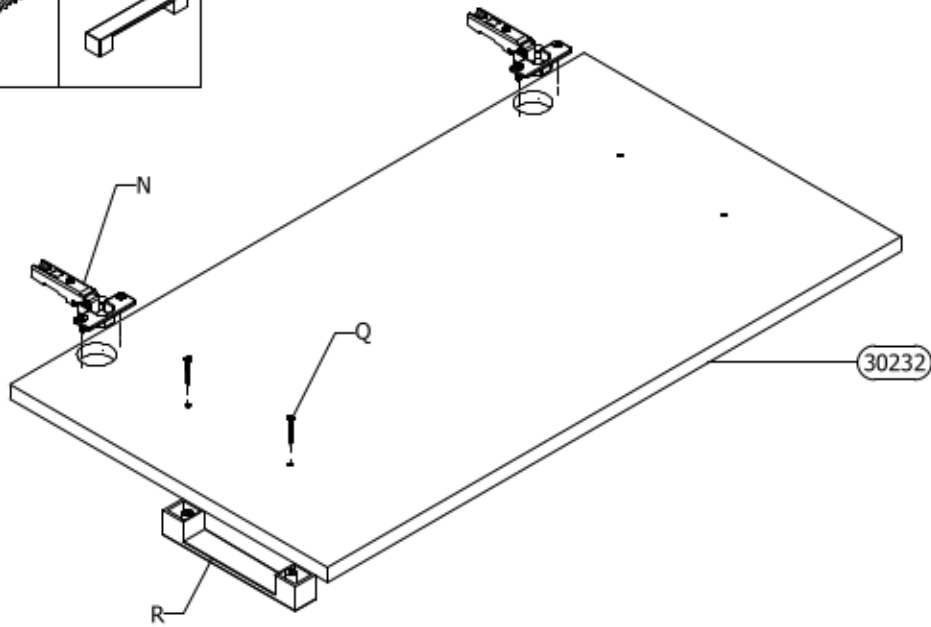
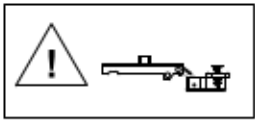

18

S x 2

Q x 2

R x 1



4x30

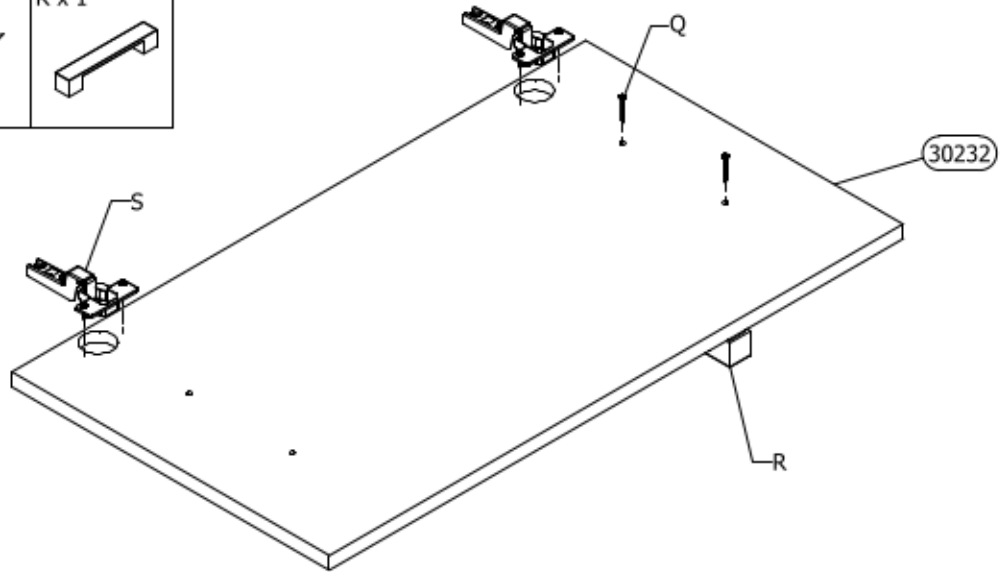

19

N x 2

R x 1

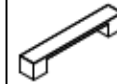

Q x 2



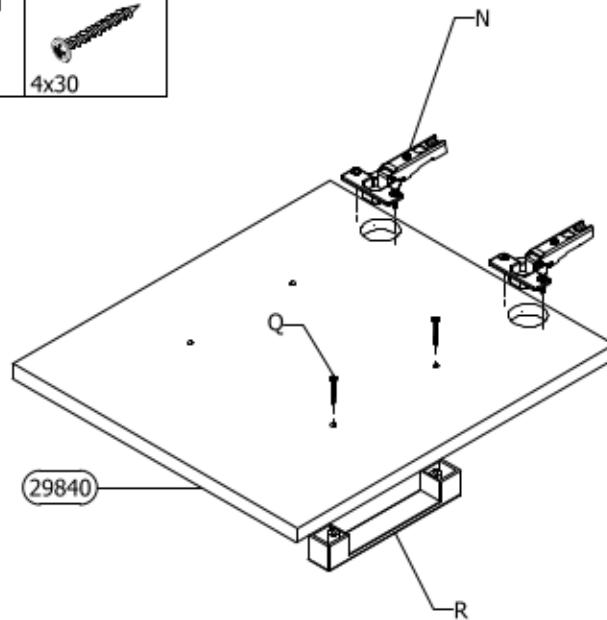
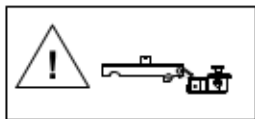

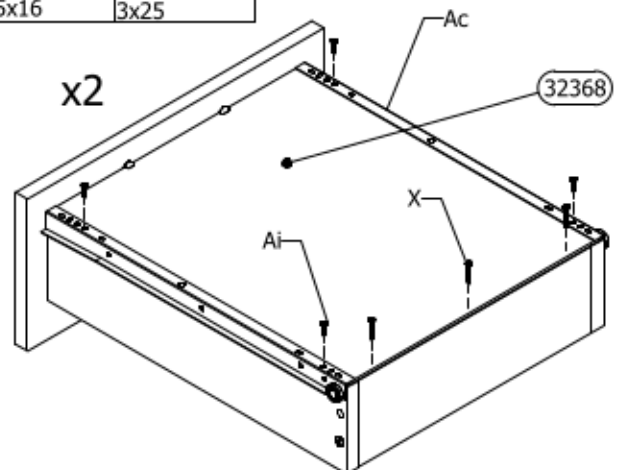
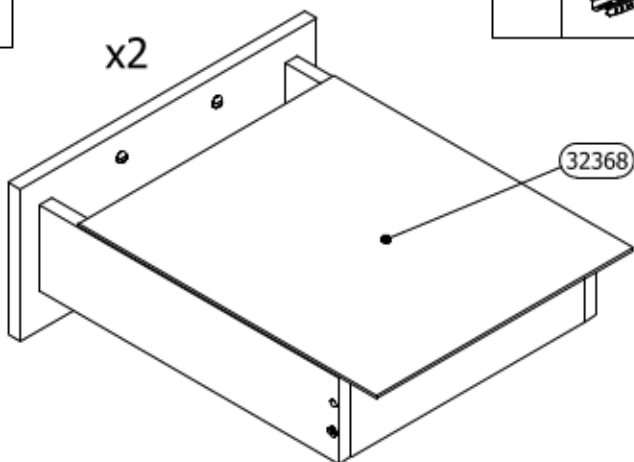
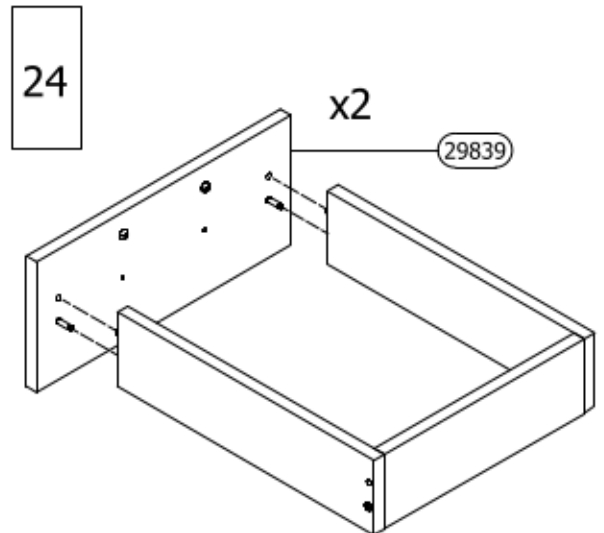
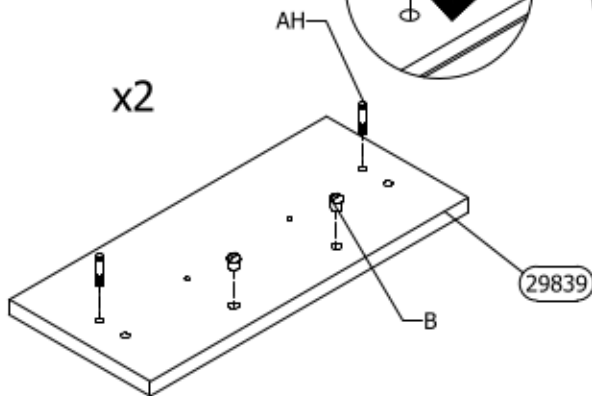
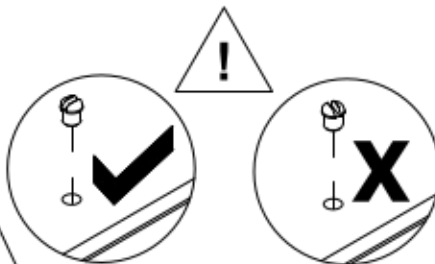
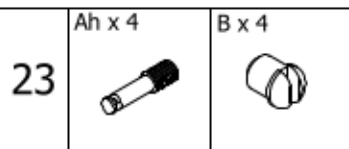
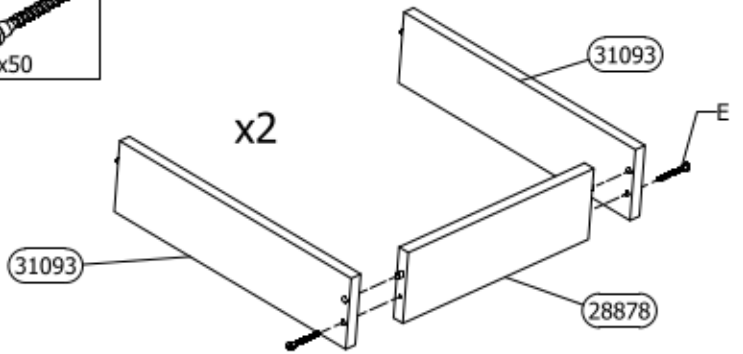
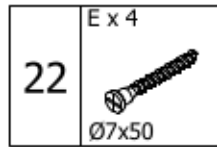
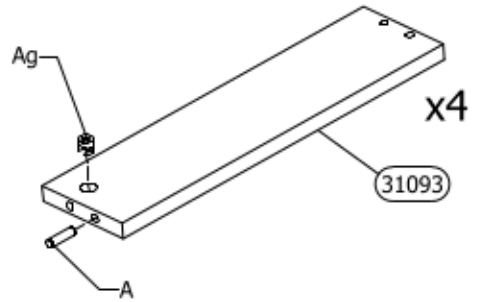
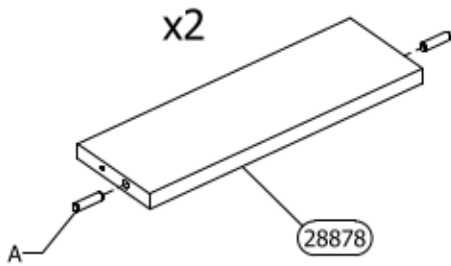
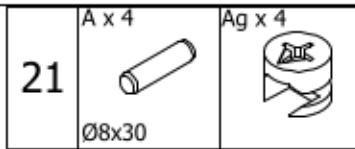
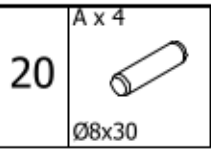

4x30

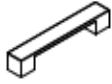

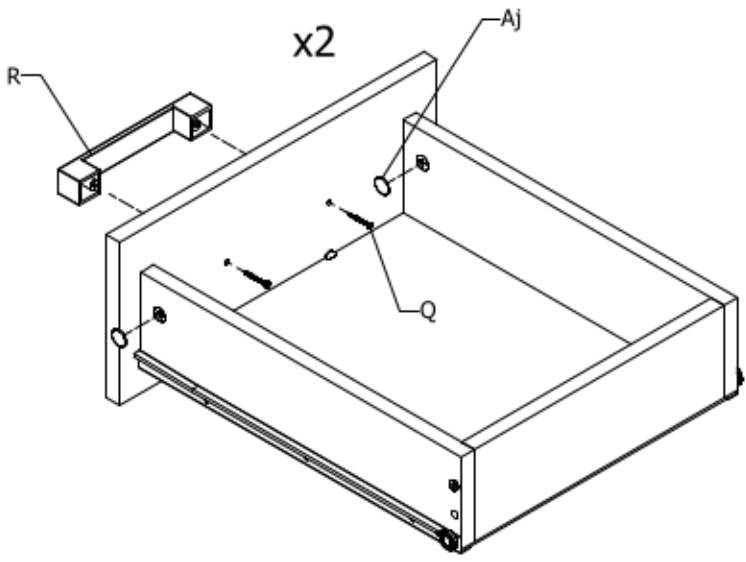



27	Aj x 4	Q x 4	R x 2
		 4x30	

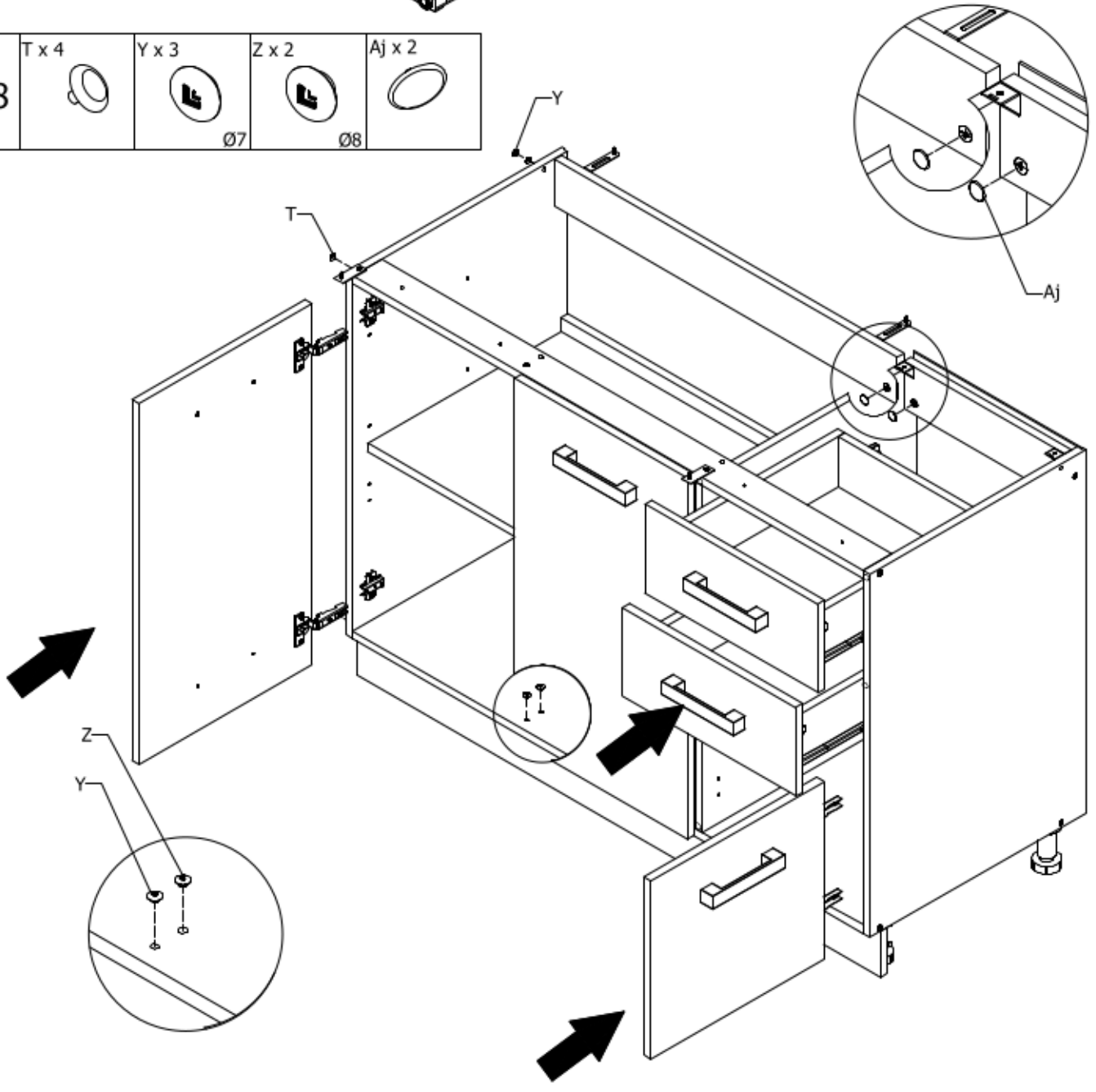

28	T x 4	Y x 3	Z x 2	Aj x 2
		 Ø7	 Ø8	



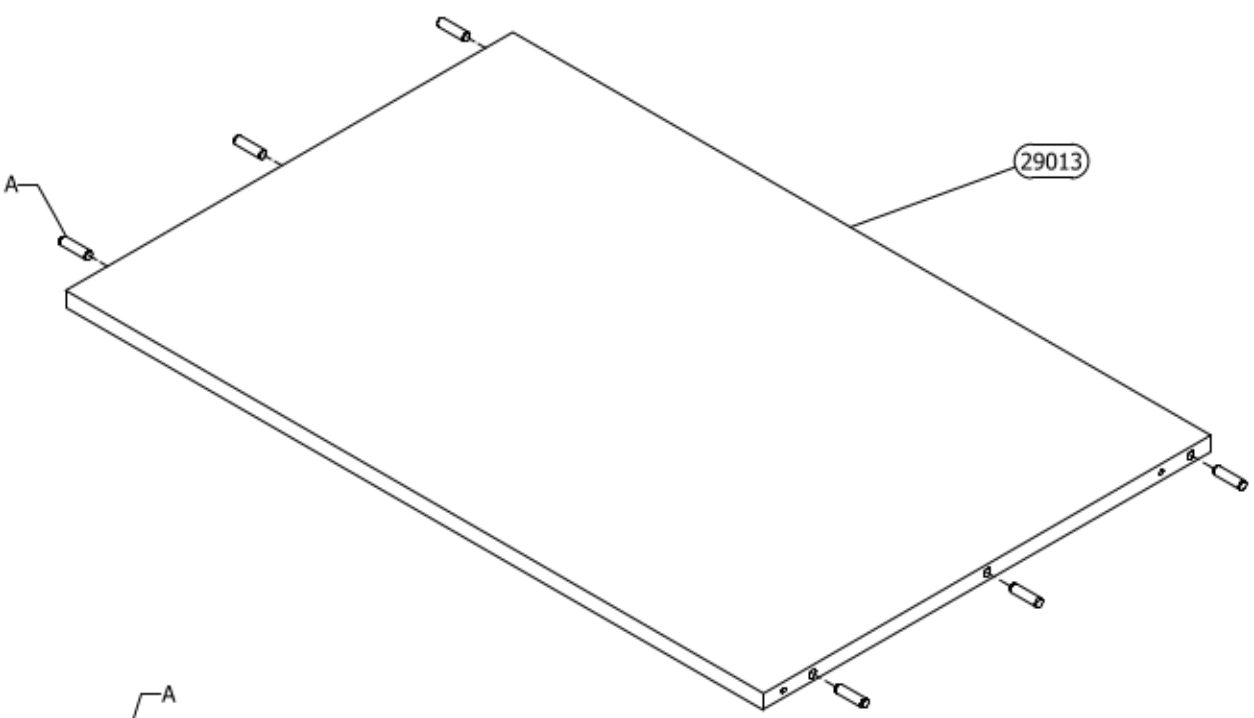

29 A x 6

 Ø8x30

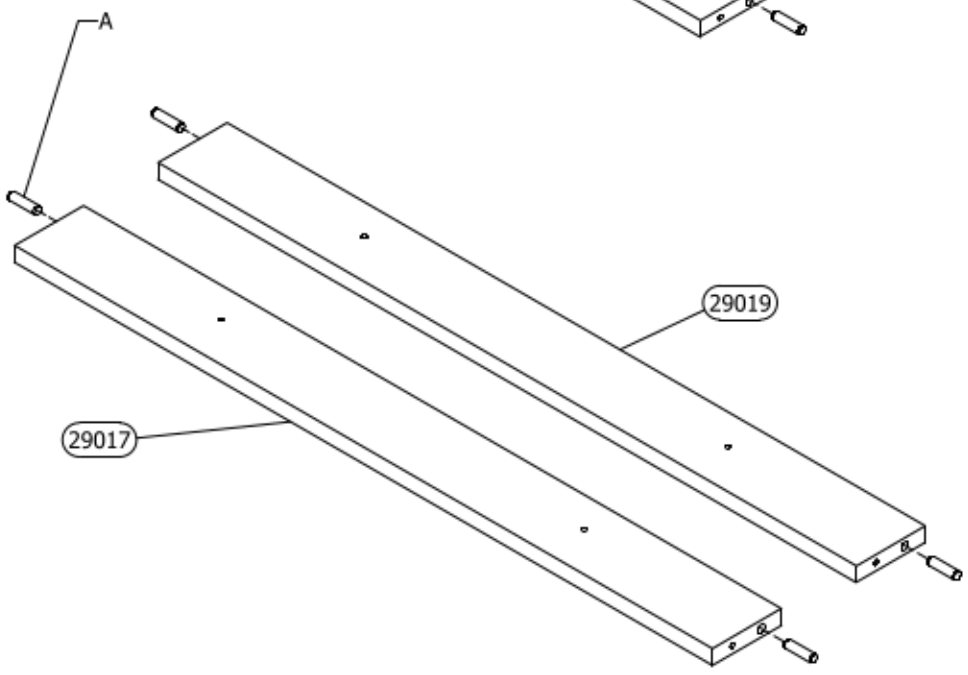

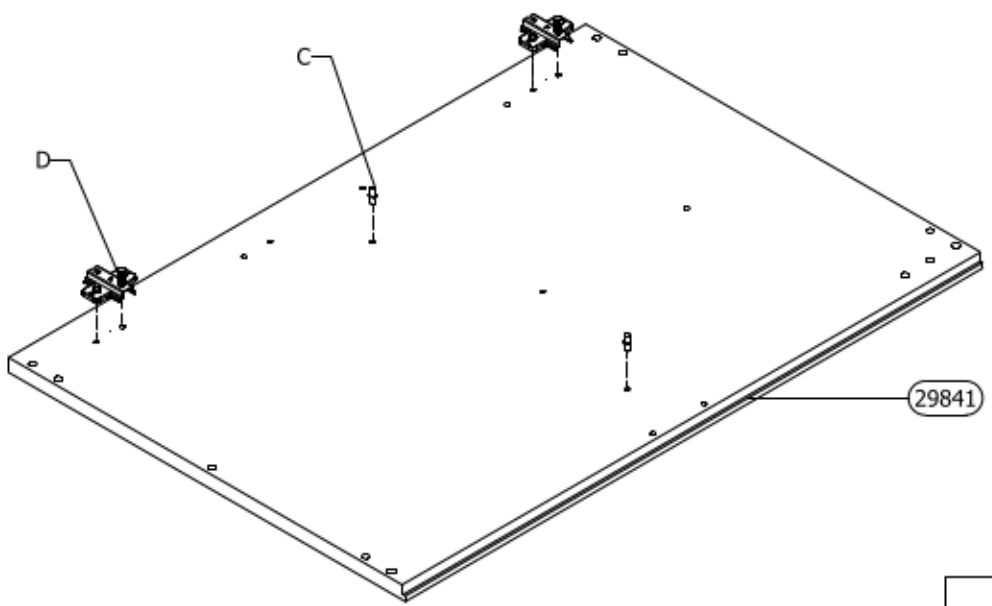

30 A x 4

 Ø8x30



31 D x 2 C x 2



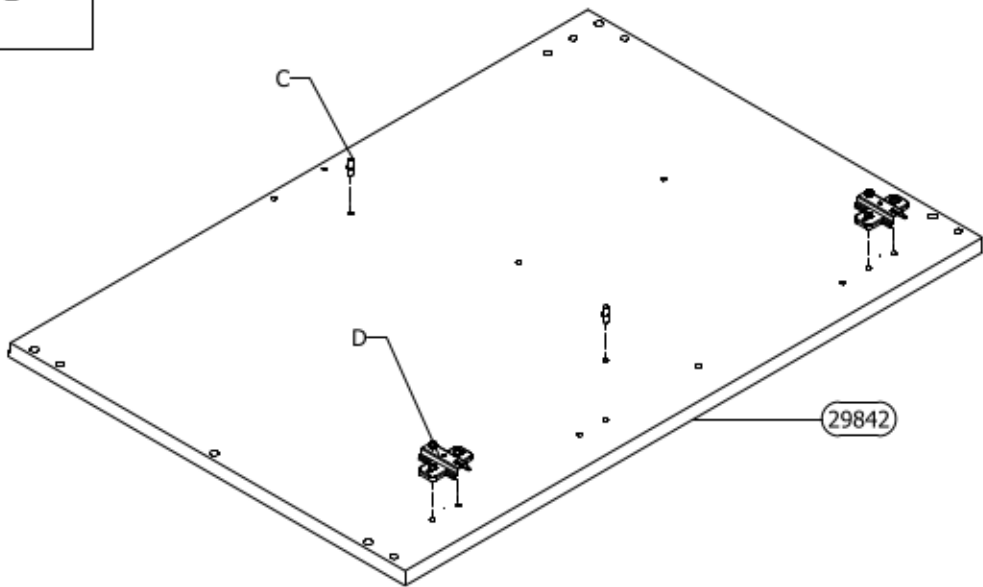

32	D x 2	C x 2
		



33	E x 8
	

Ø7x50

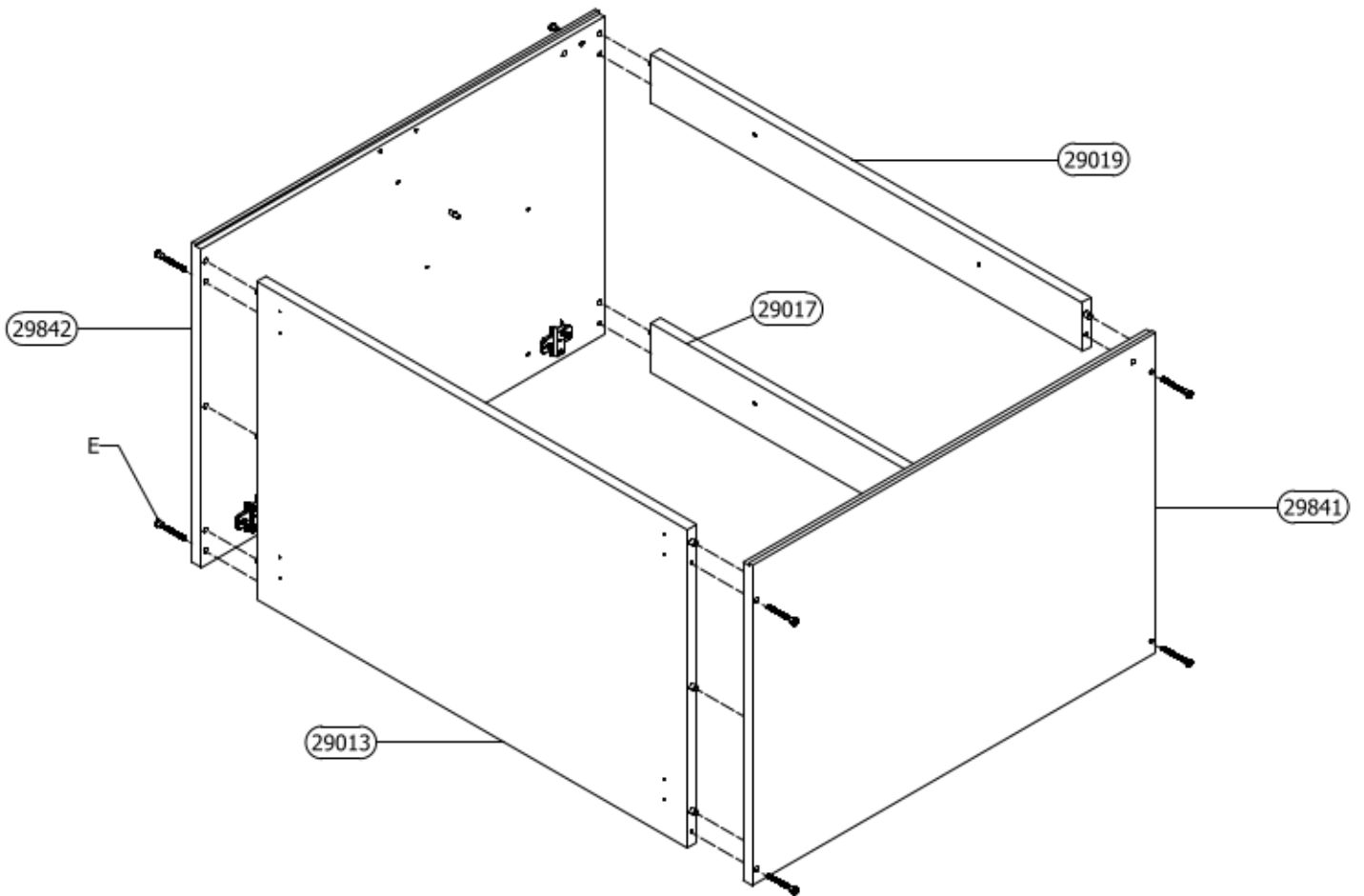

34

F x 23

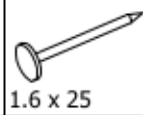

1.6 x 25

Ae x 4



J x 16



4x16

I x 1



L=680mm



d1=d2

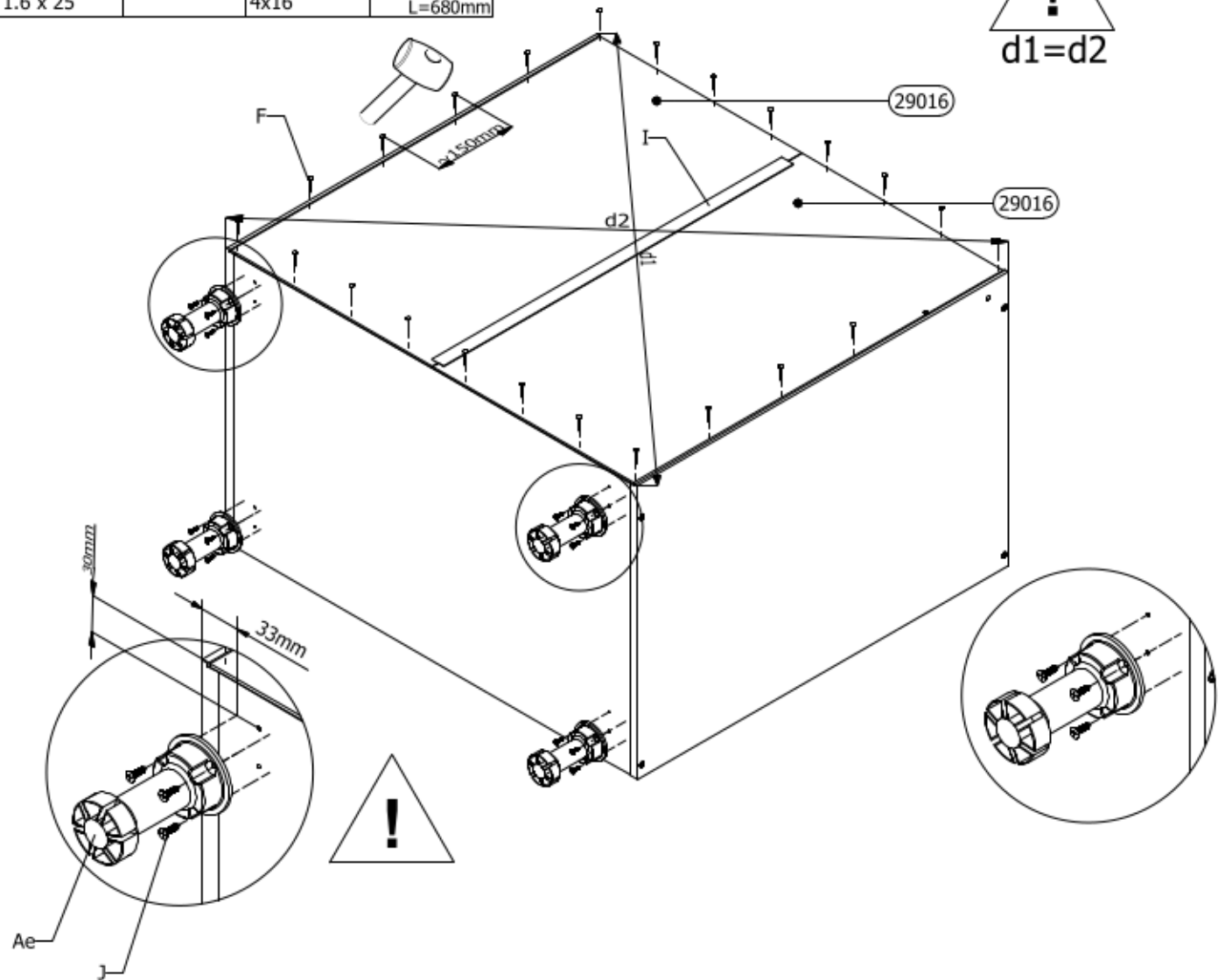

35

Af x 2



J x 2



4x16

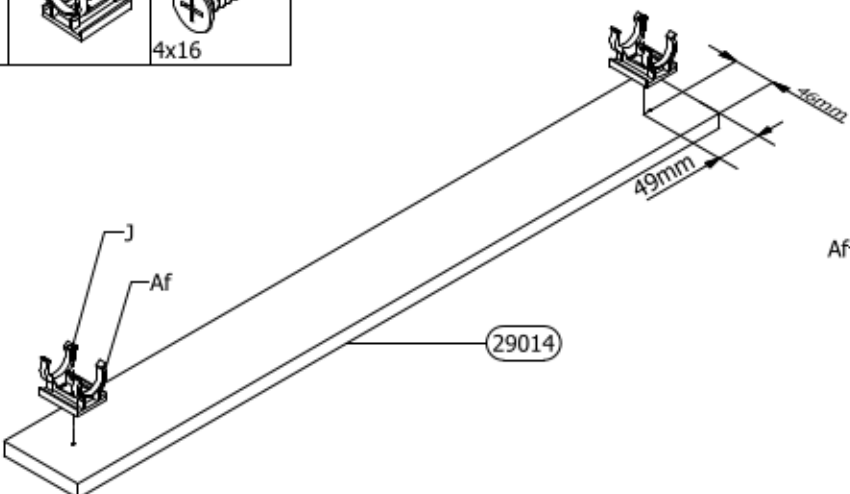

36

J x 2



4x16

Af x 1



Ak x 1

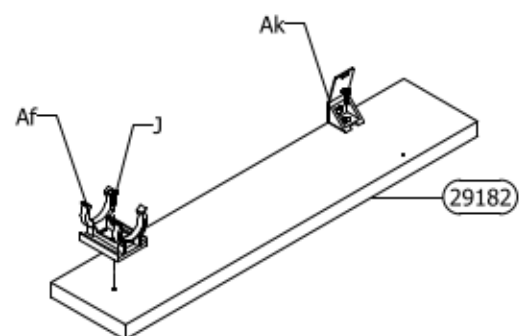

37

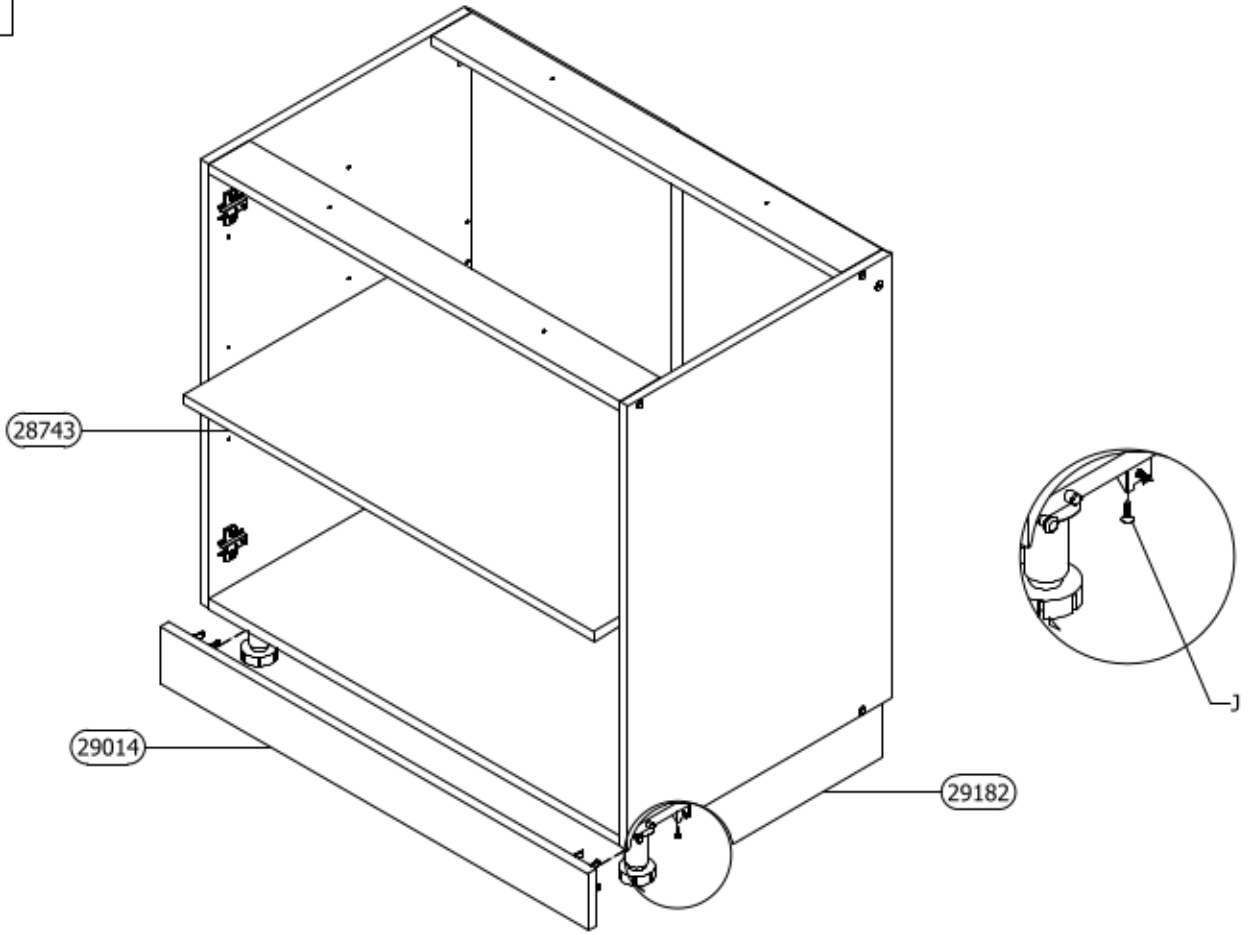
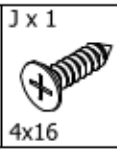

38

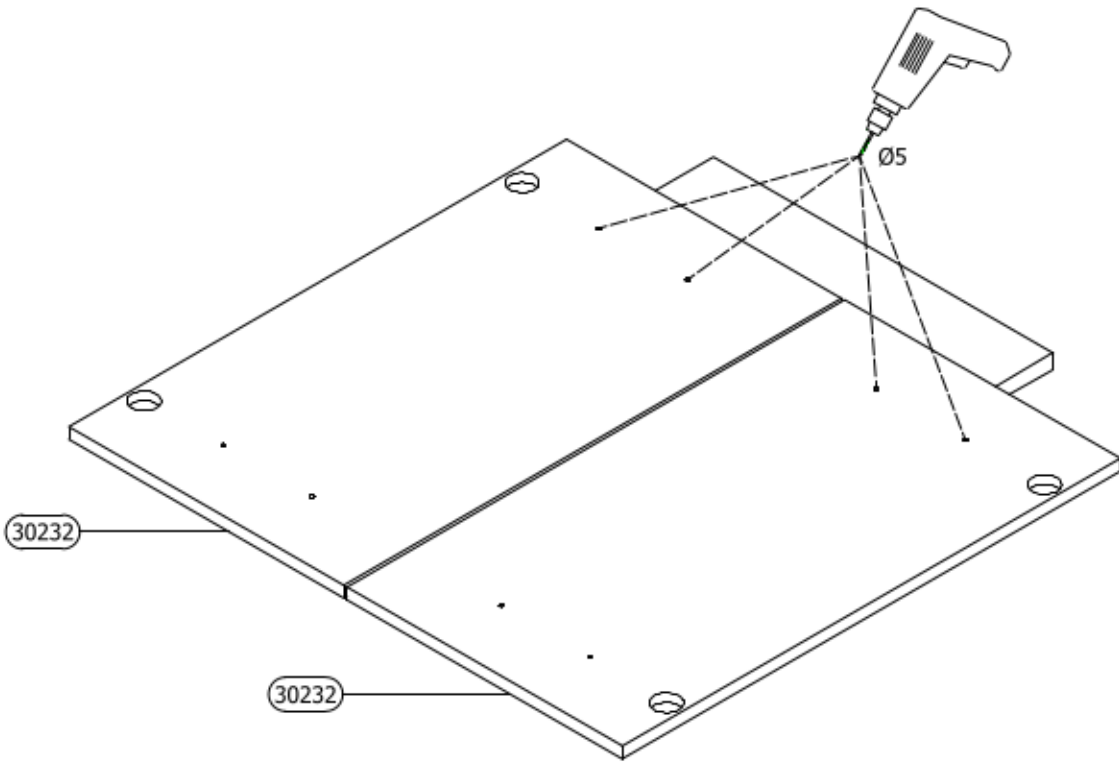

39

R x 1	Q x 2	N x 2
	4x30	

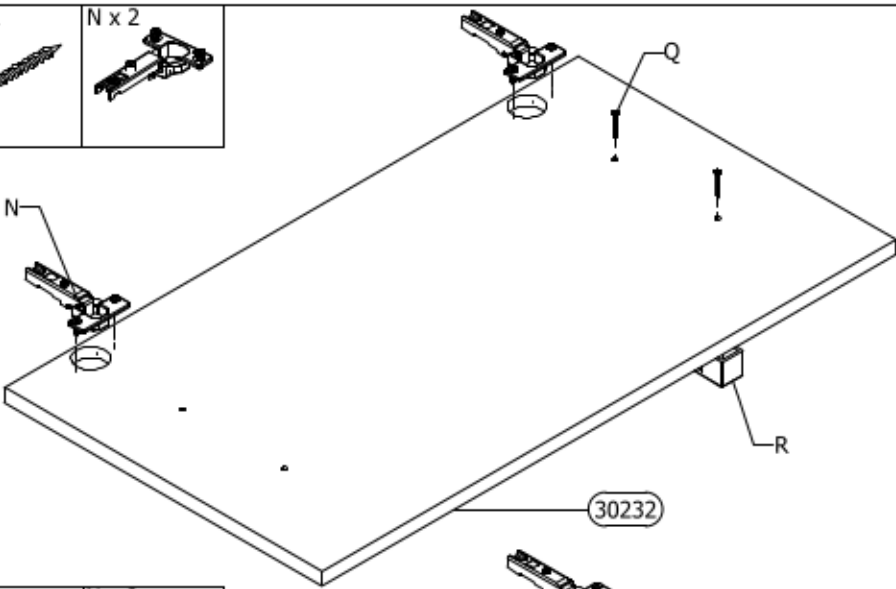
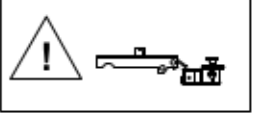

40

R x 1	Q x 2	N x 2
	4x30	

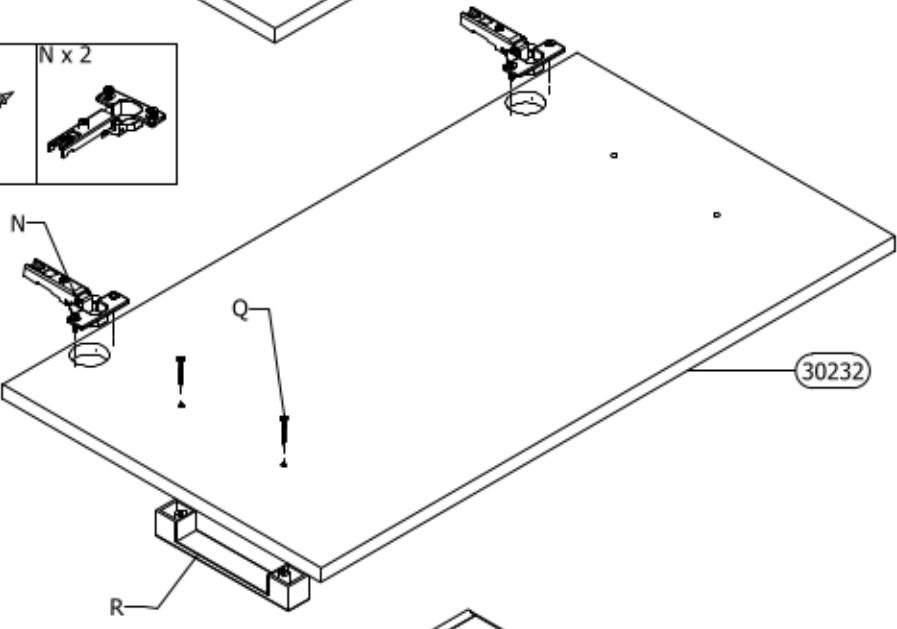
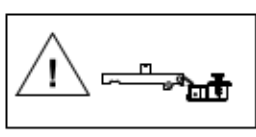

41

T x 4	Y x 1

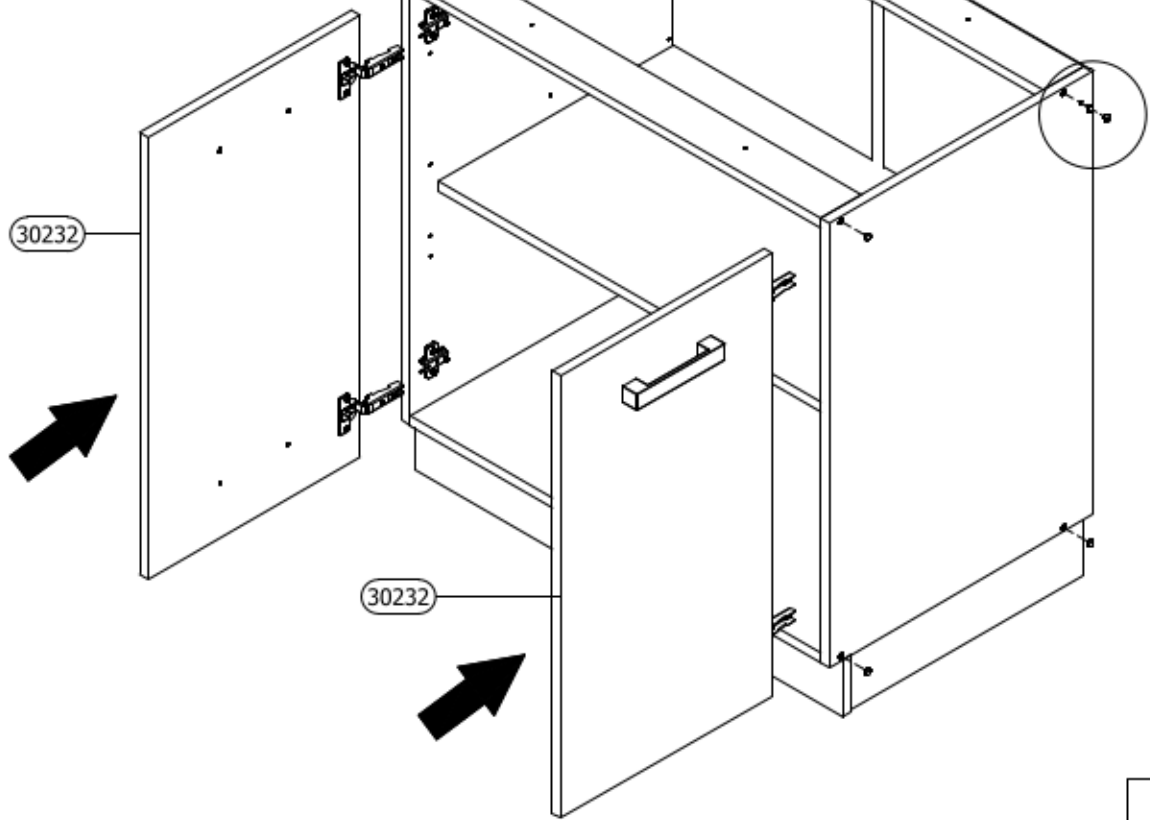
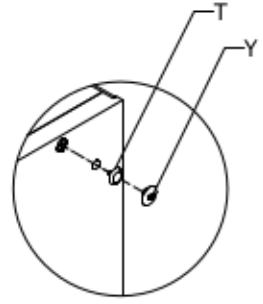

42

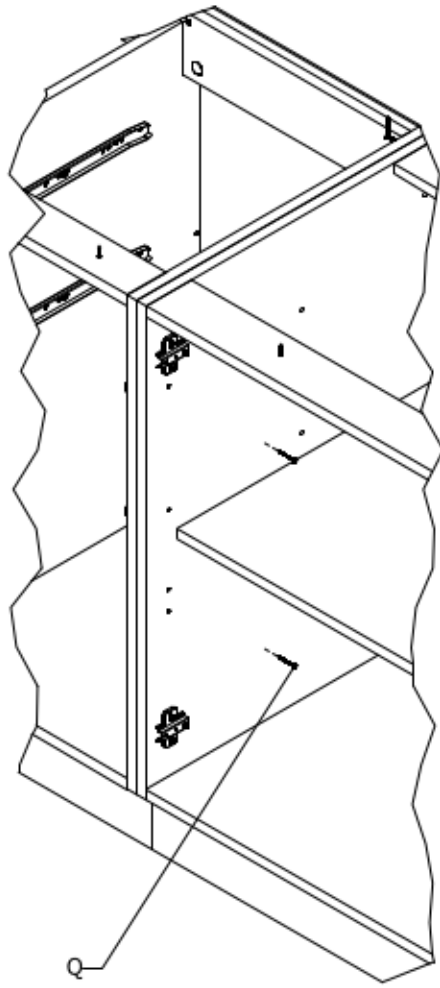

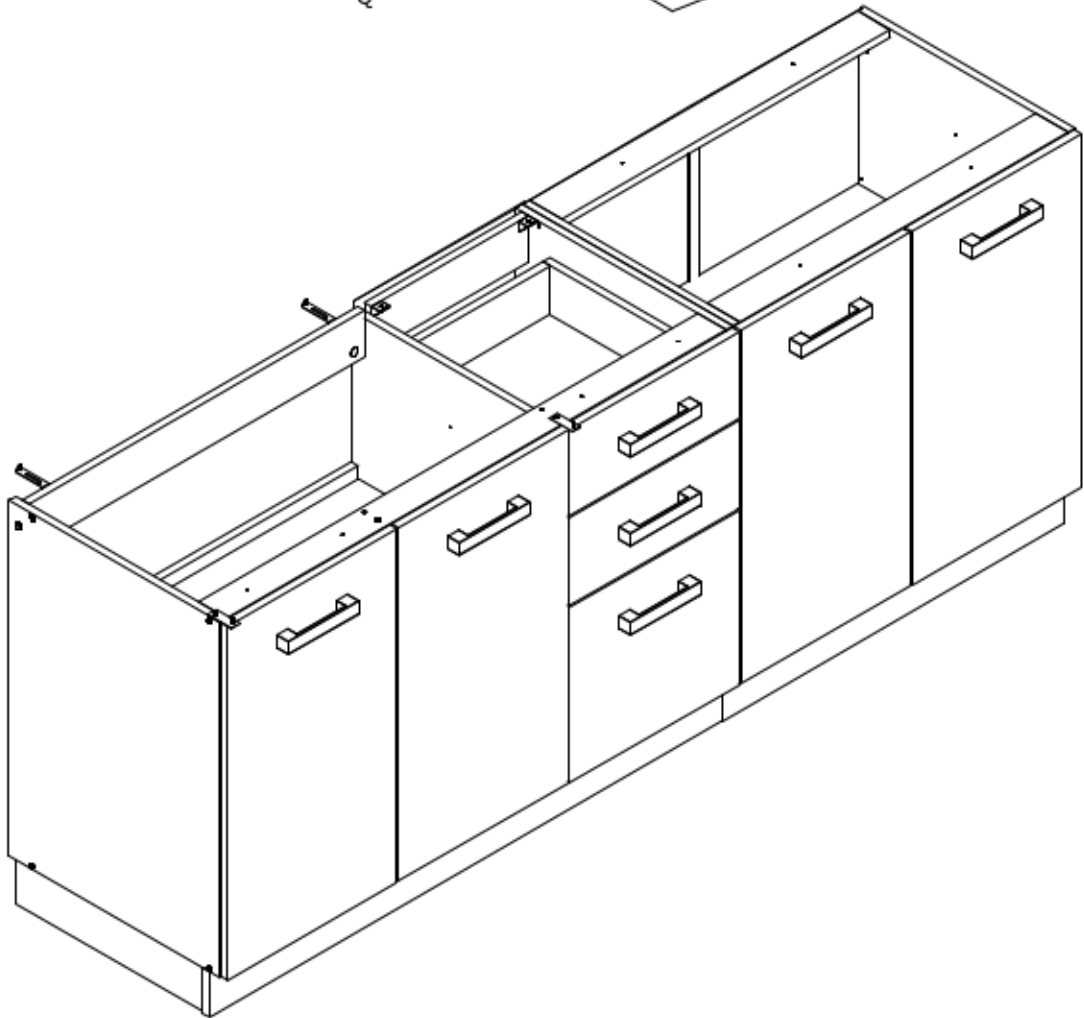

43



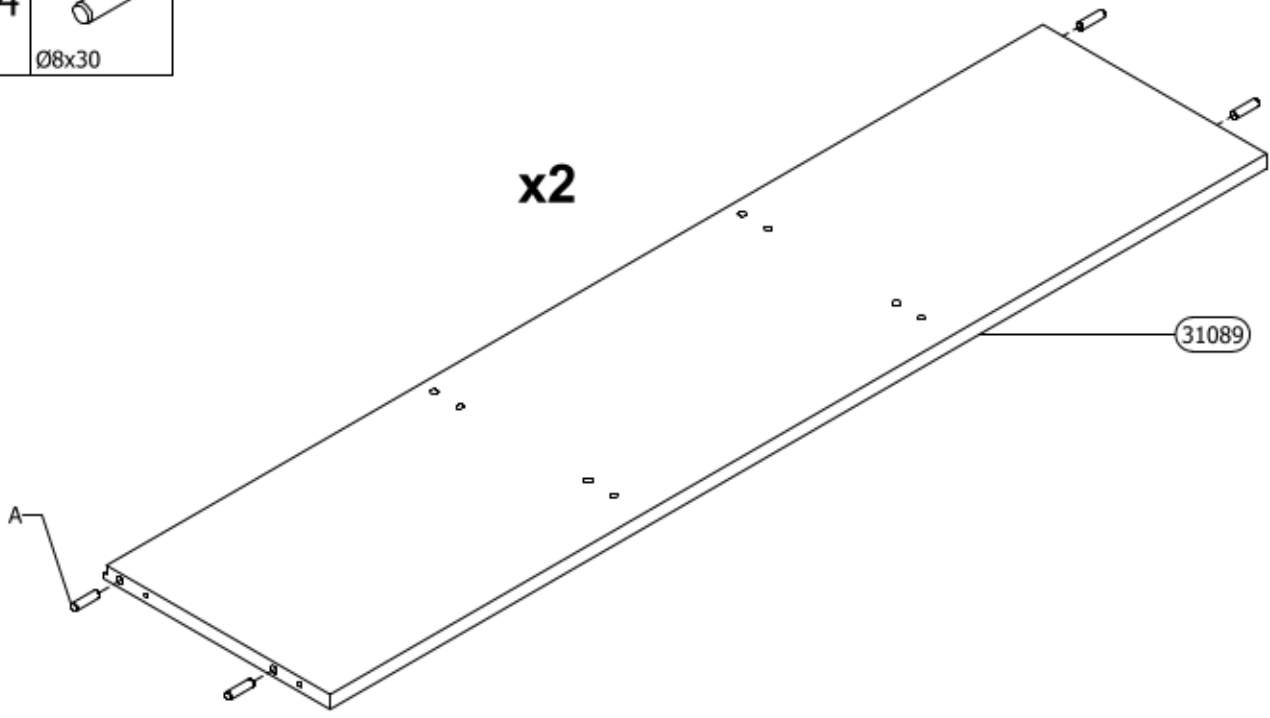

44	A x 8	
	Ø8x30	

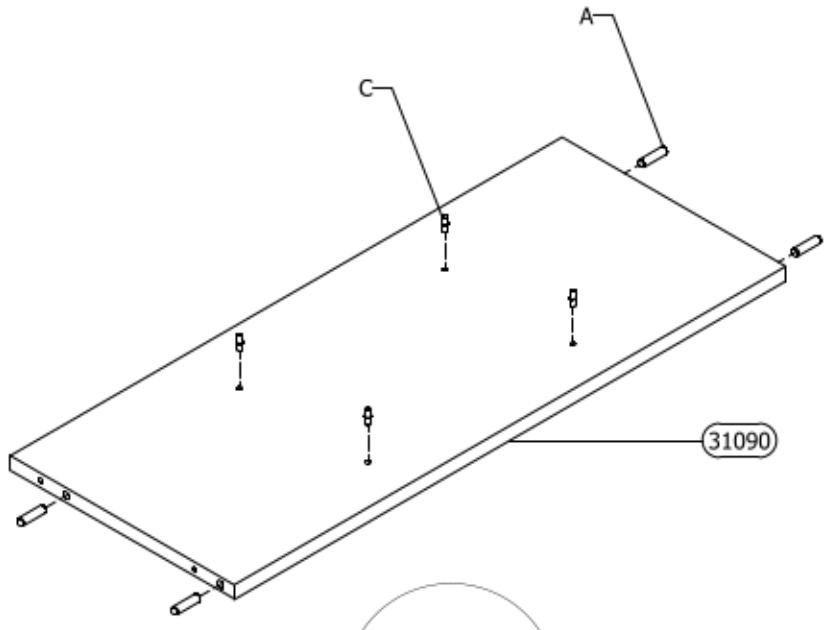

45	A x 4		C x 4	
	Ø8x30			



46	C x 4		D x 2	

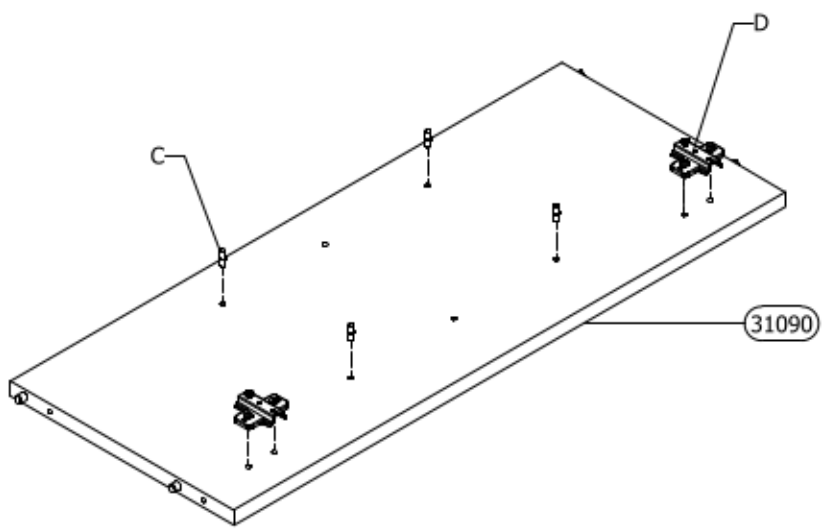

47

D x 2



C x 4

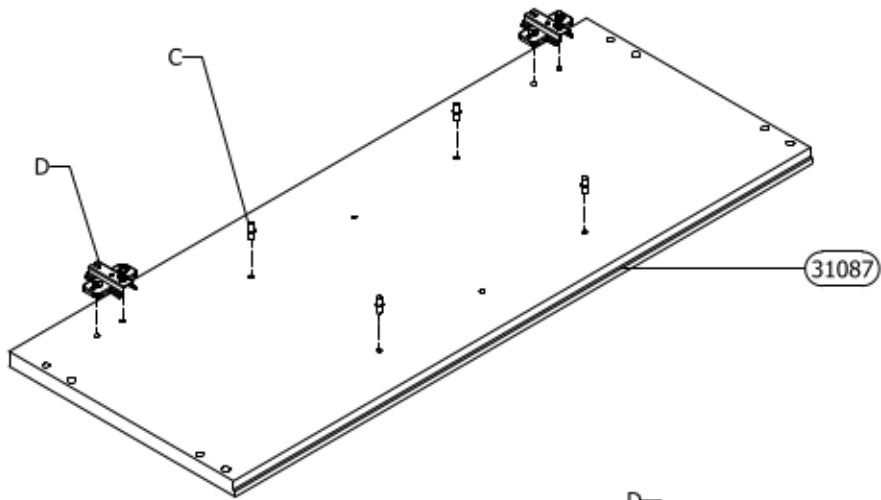

48

C x 4



D x 2

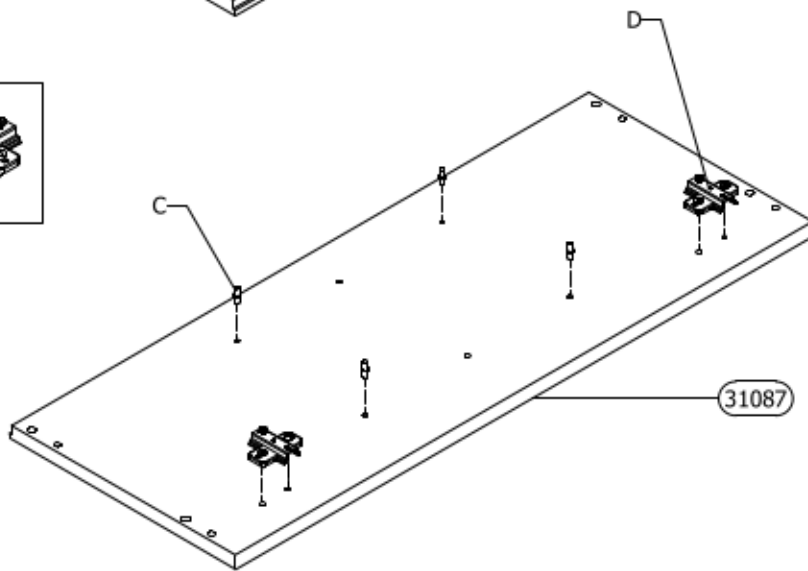

49

E x 4



Ø7x50

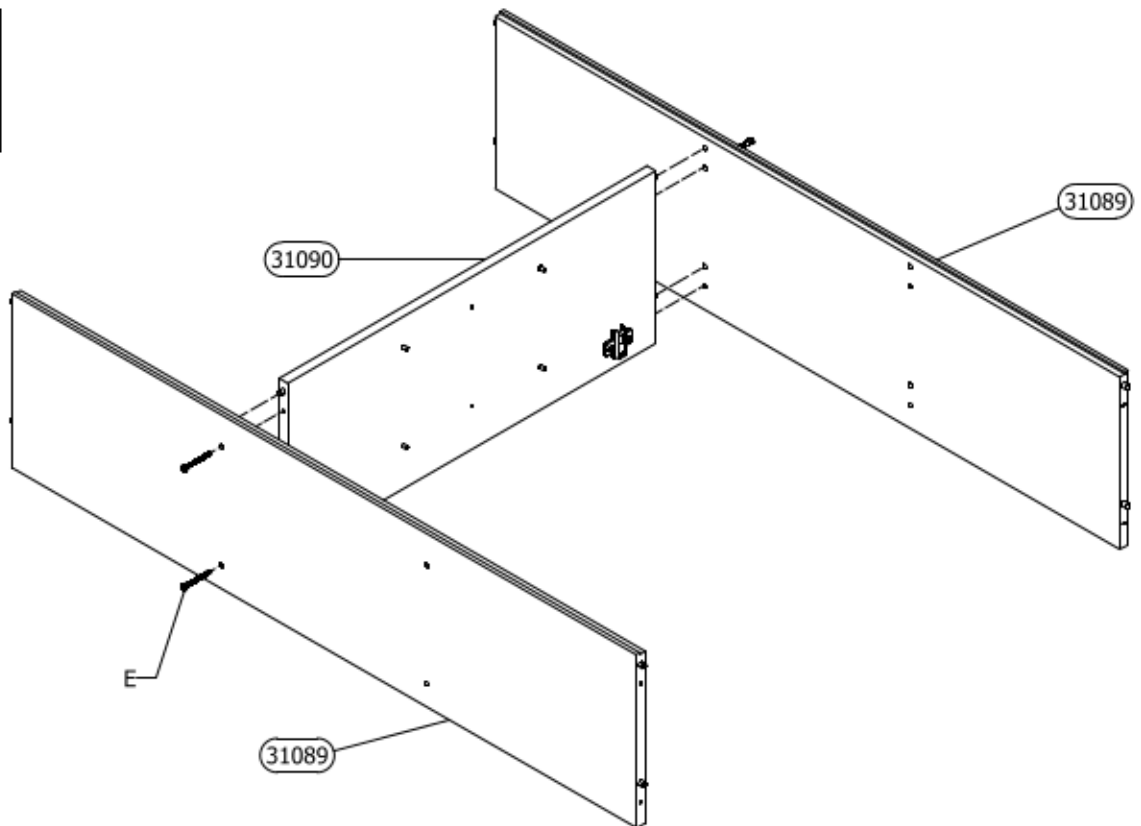

50

E x 8



Ø7x50

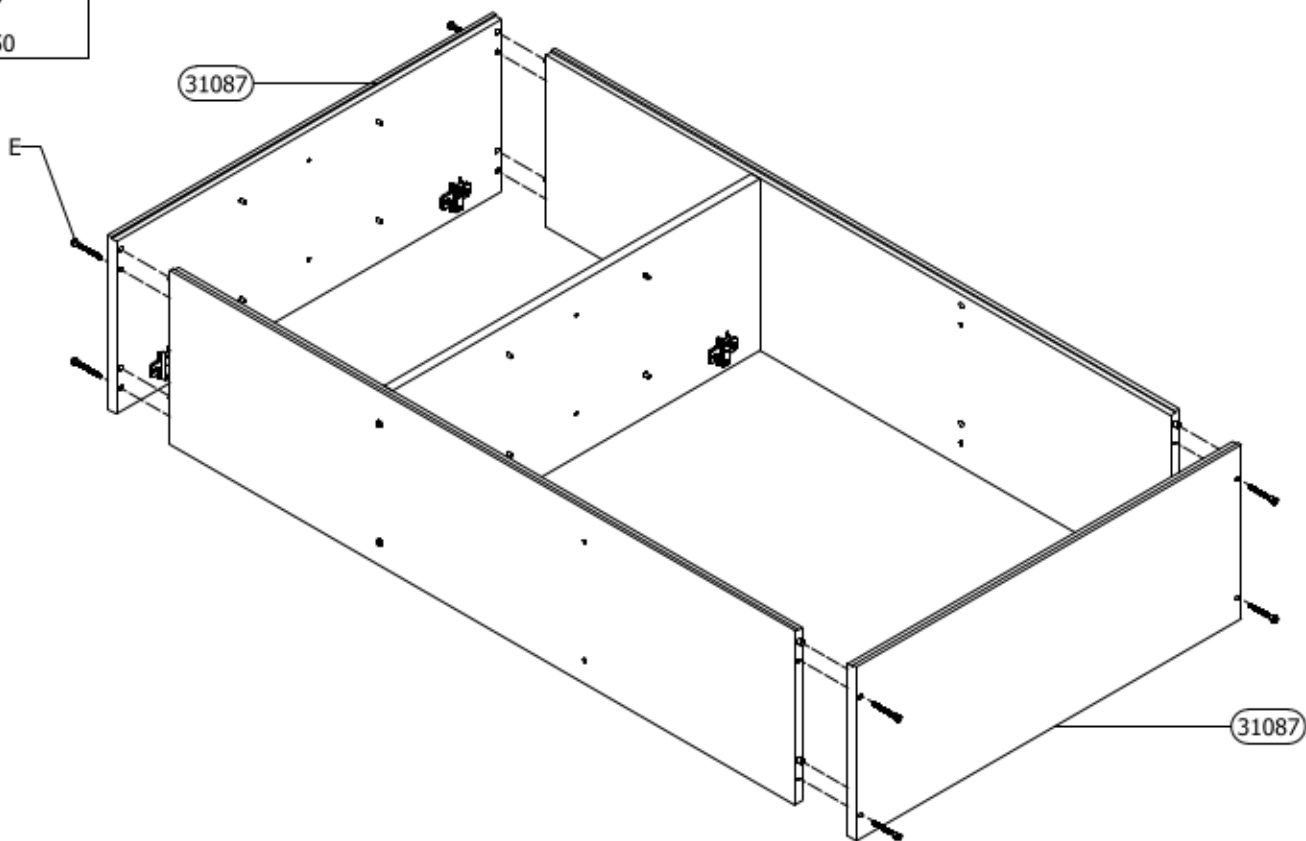

51

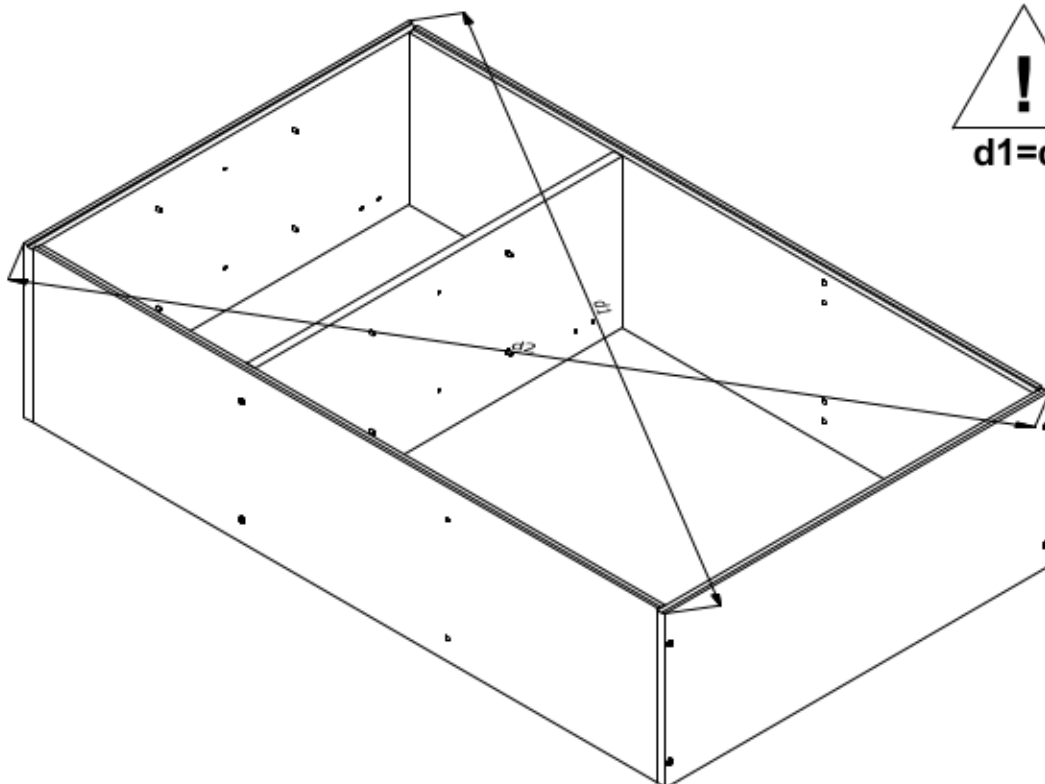

52

W x 3



X x 3



3x25

F x 32



1.6 x 25

O x 3



4x35

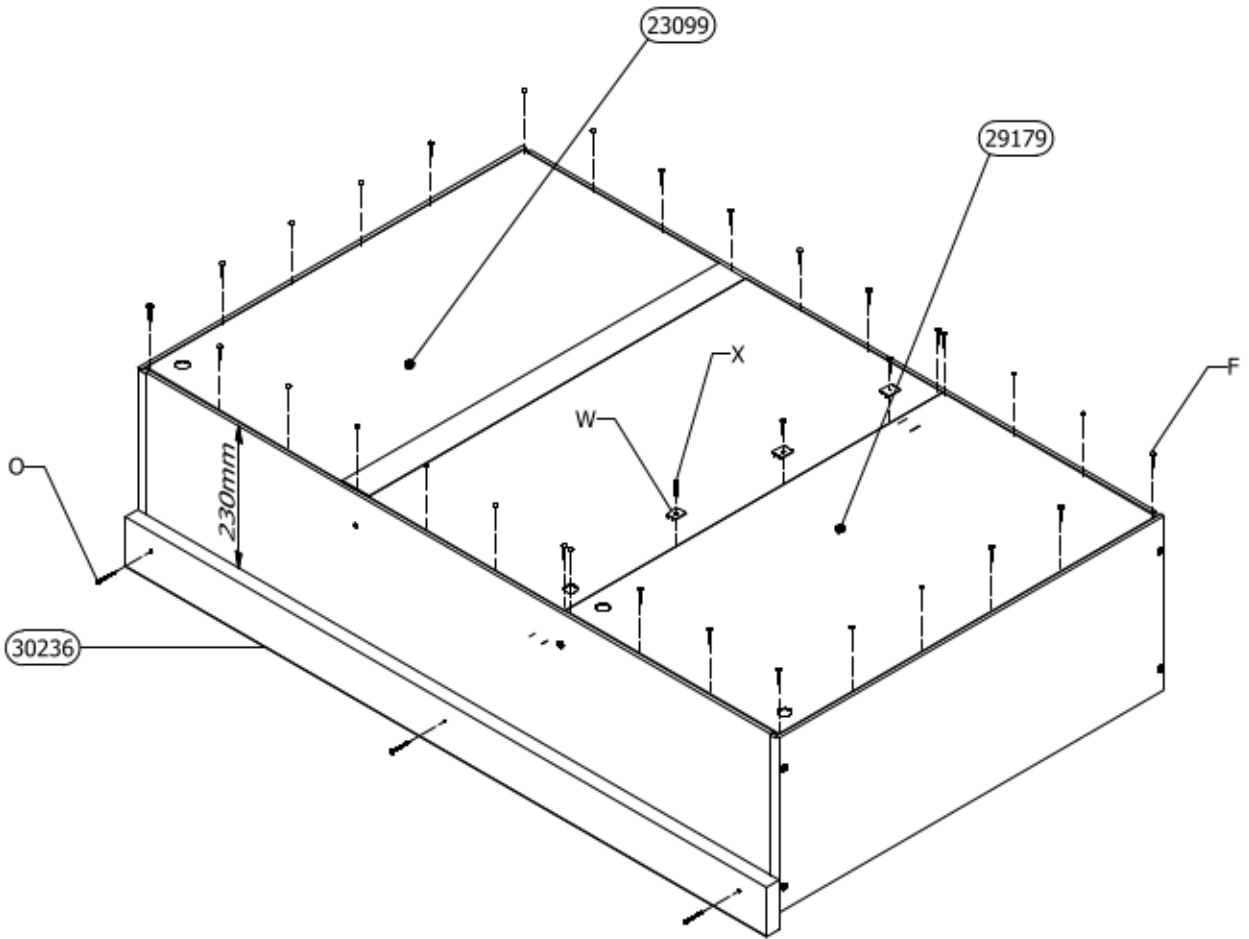

53

K x 2



L x 2



J x 8



V x 2

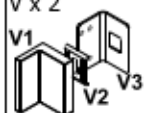

6x60

4x16

Ø10

~1129mm

max
20Kg



K

V2

V3

L

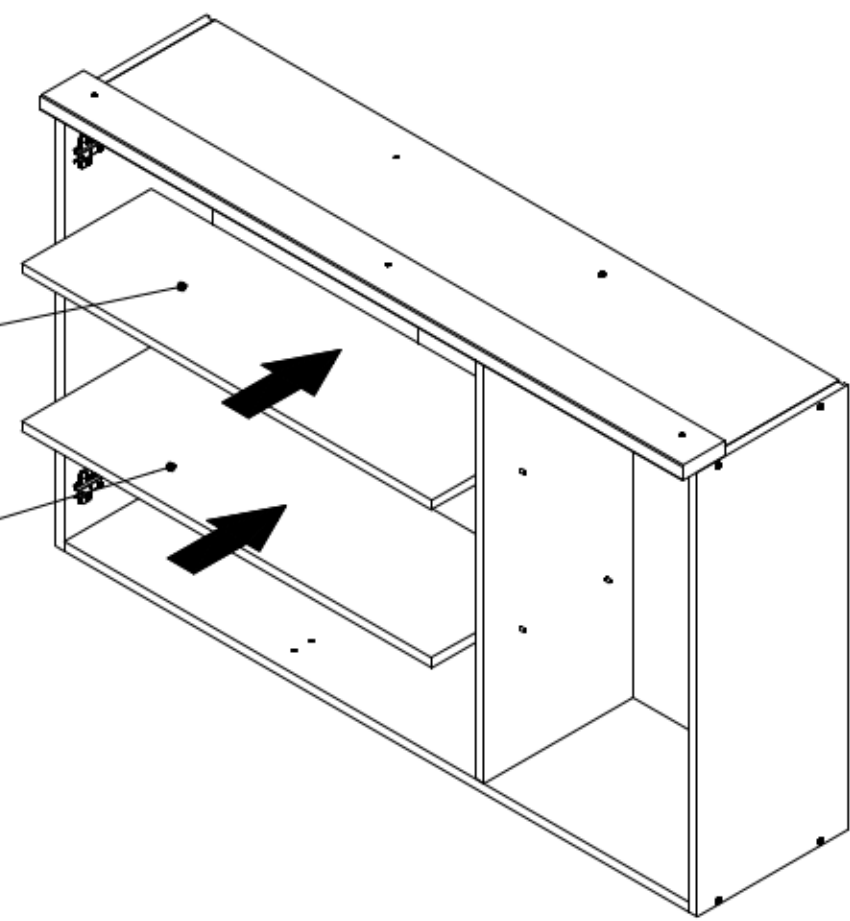
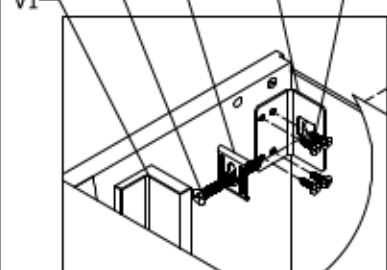

V1



54

31091

31091

55	Y x 3	Z x 3	T x 4
			
	Ø7	Ø8	

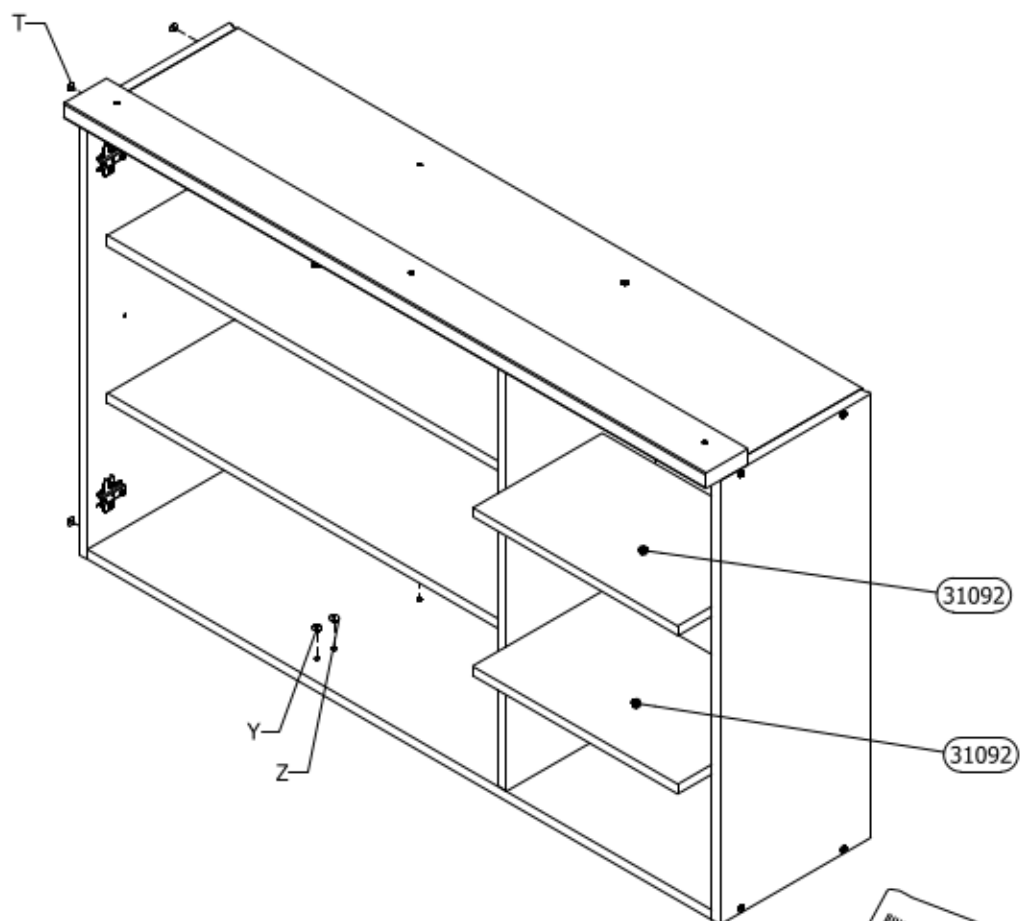

56

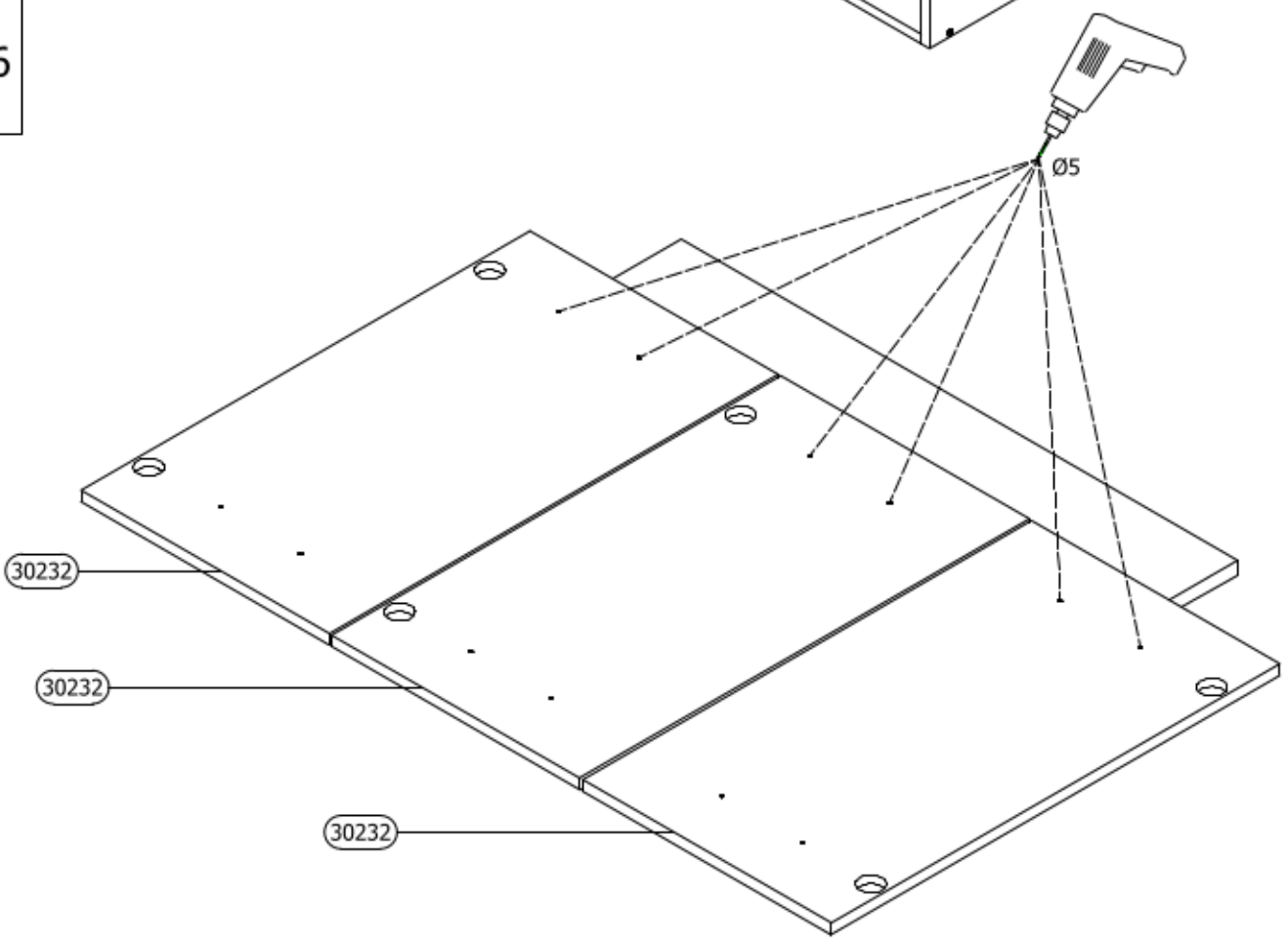

57

N x 2	Q x 2	R x 1
-------	-------	-------

4x30

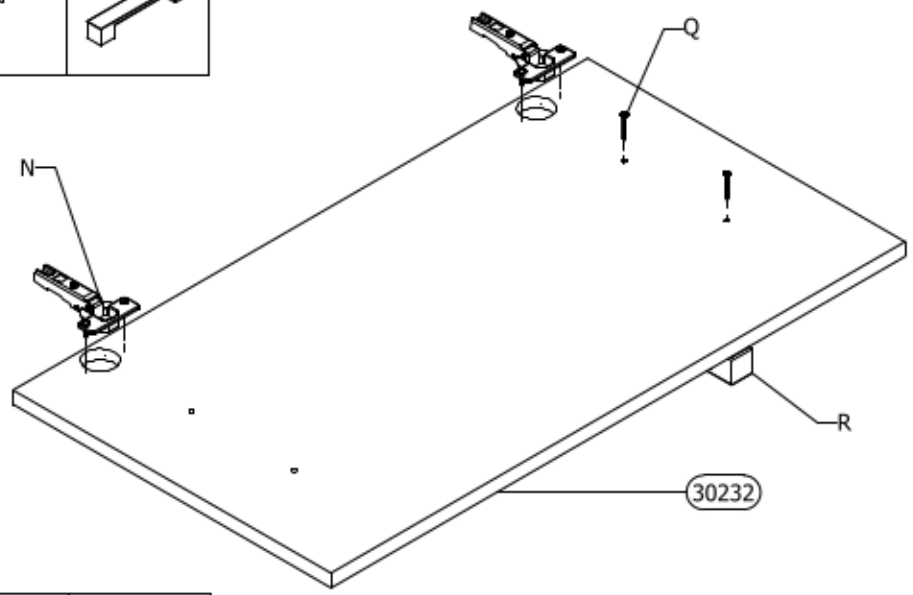
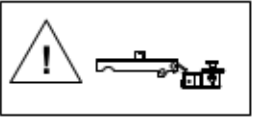

58

N x 4	Q x 4	R x 2
-------	-------	-------

4x30

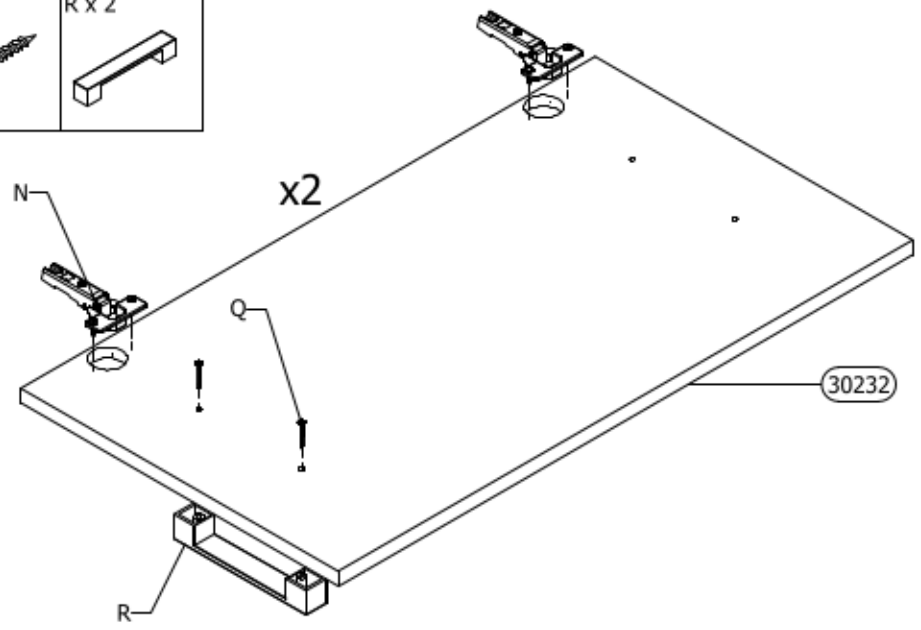
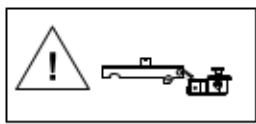

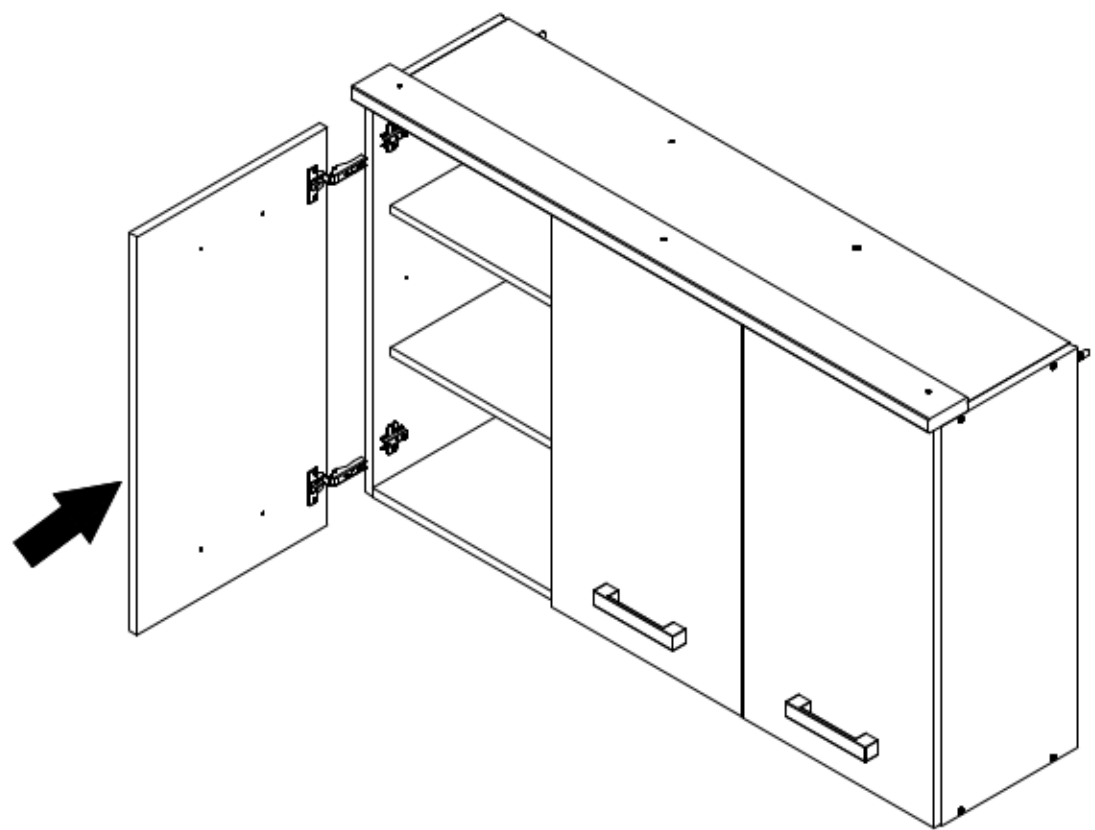

59



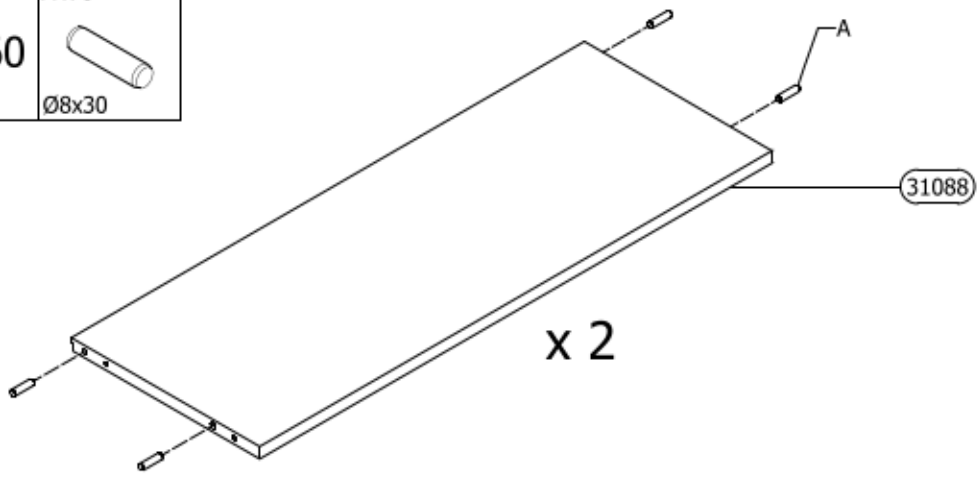

60 A x 8

 Ø8x30

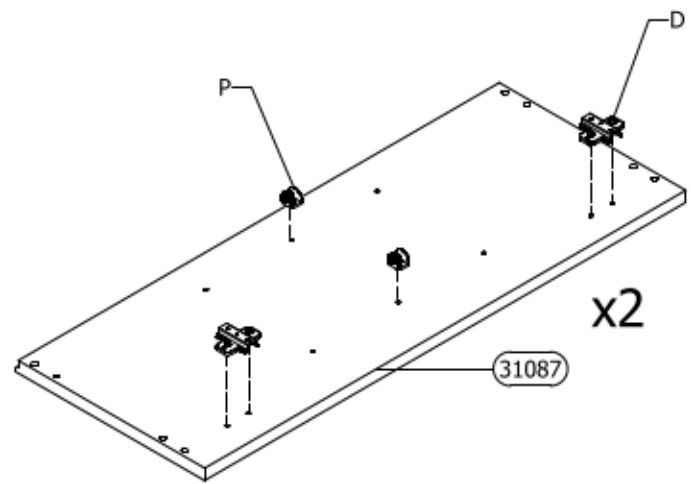

61 D x 4 P x 4



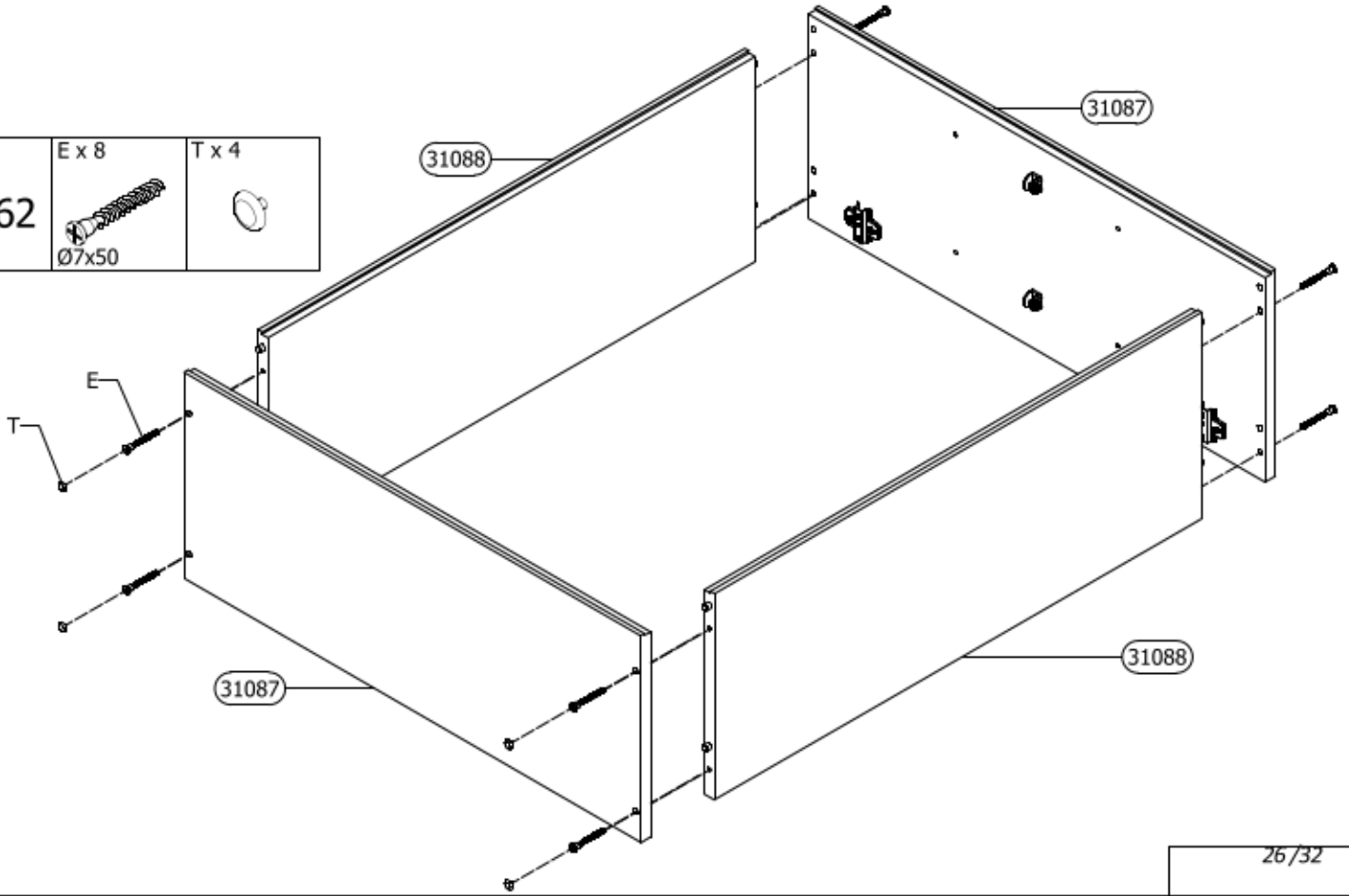

62 E x 8 T x 4

 Ø7x50

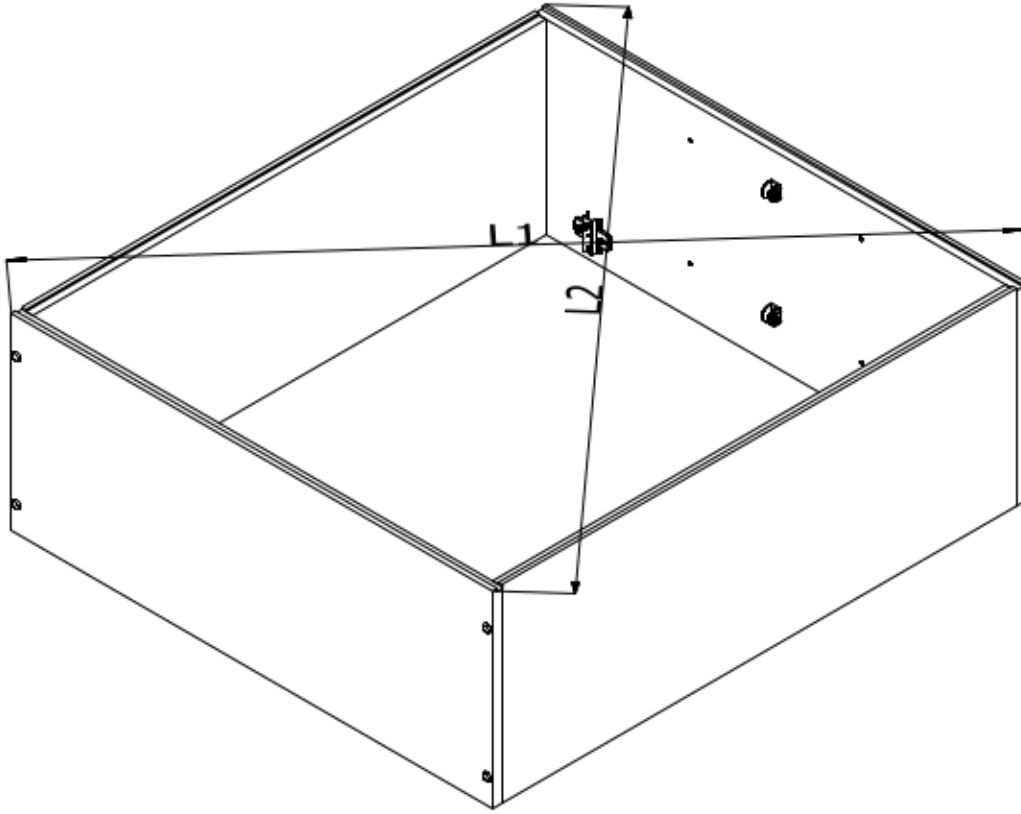

63

!
L1=L2



64

F x 26

O x 2

1.6 x 25

4x35

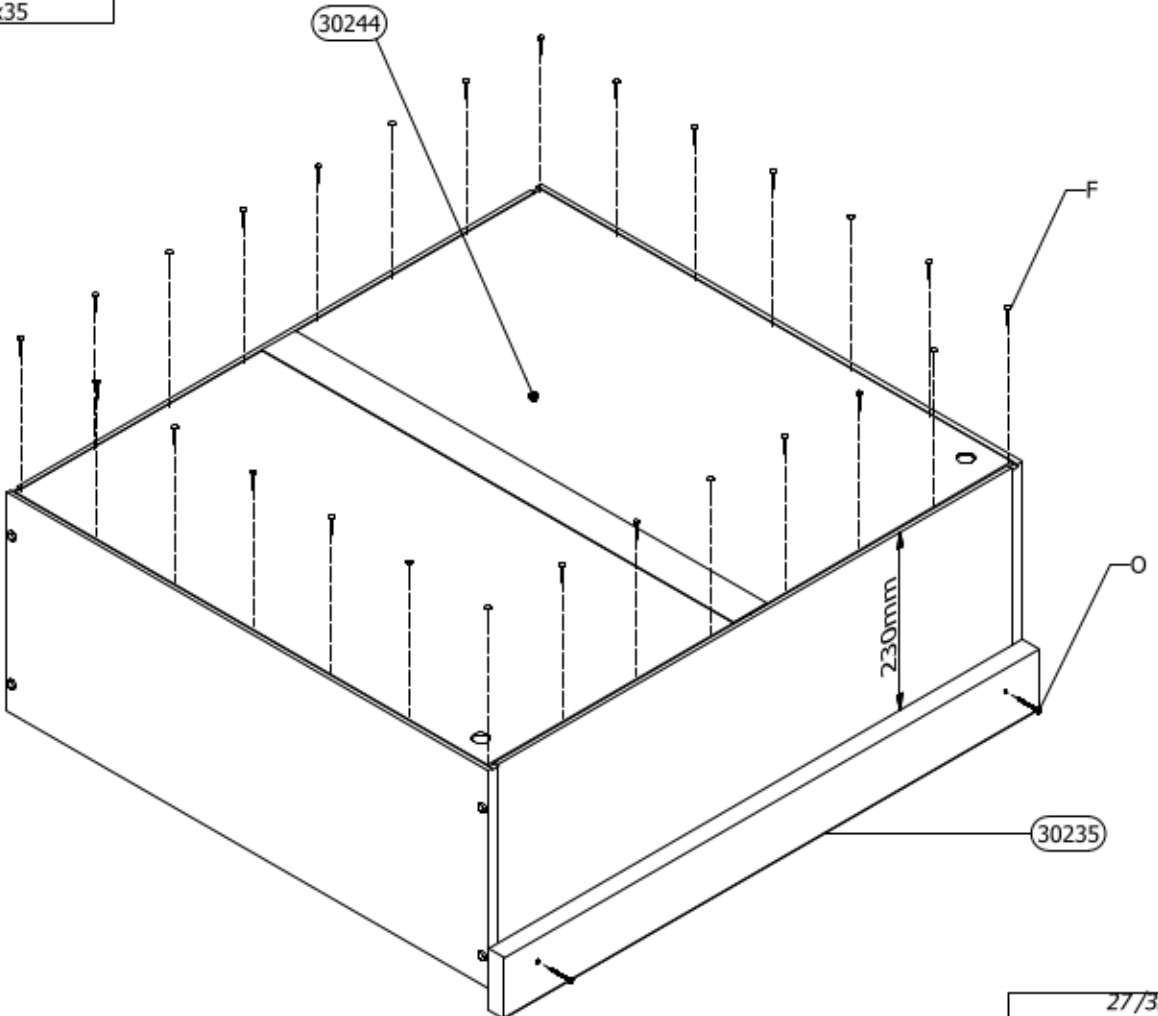

65

V1 x 2

J x 8

4x16

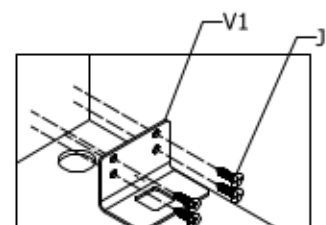
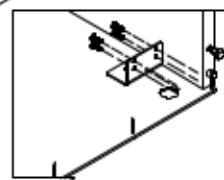
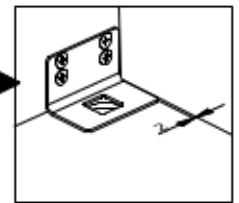
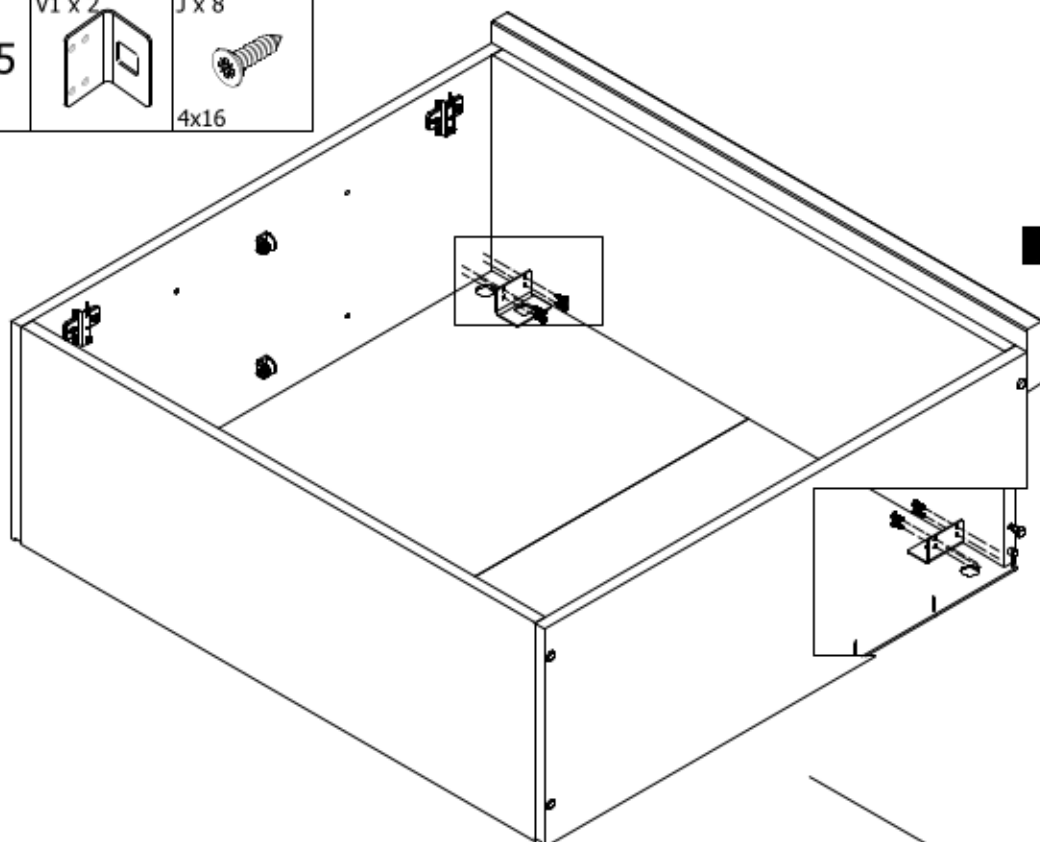

67

V2 x 2

V3 x 2

L x 2

6x60

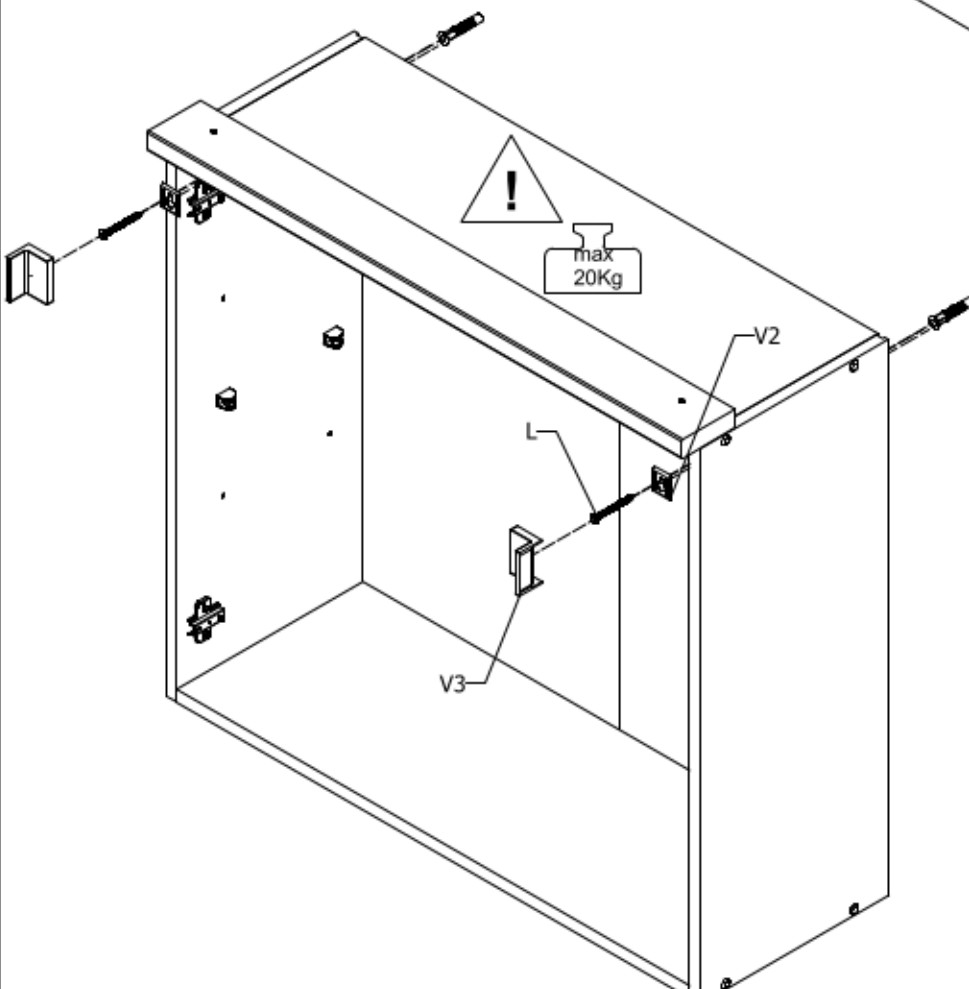

66

K x 2

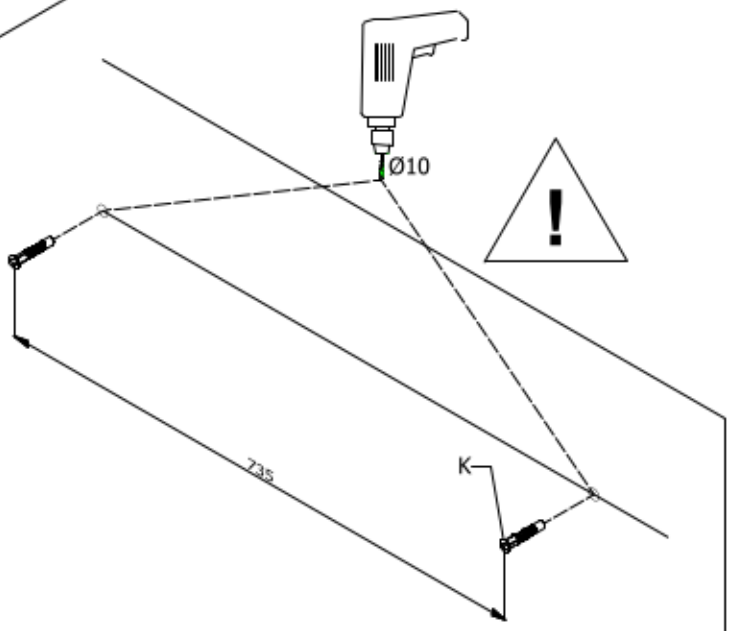

68

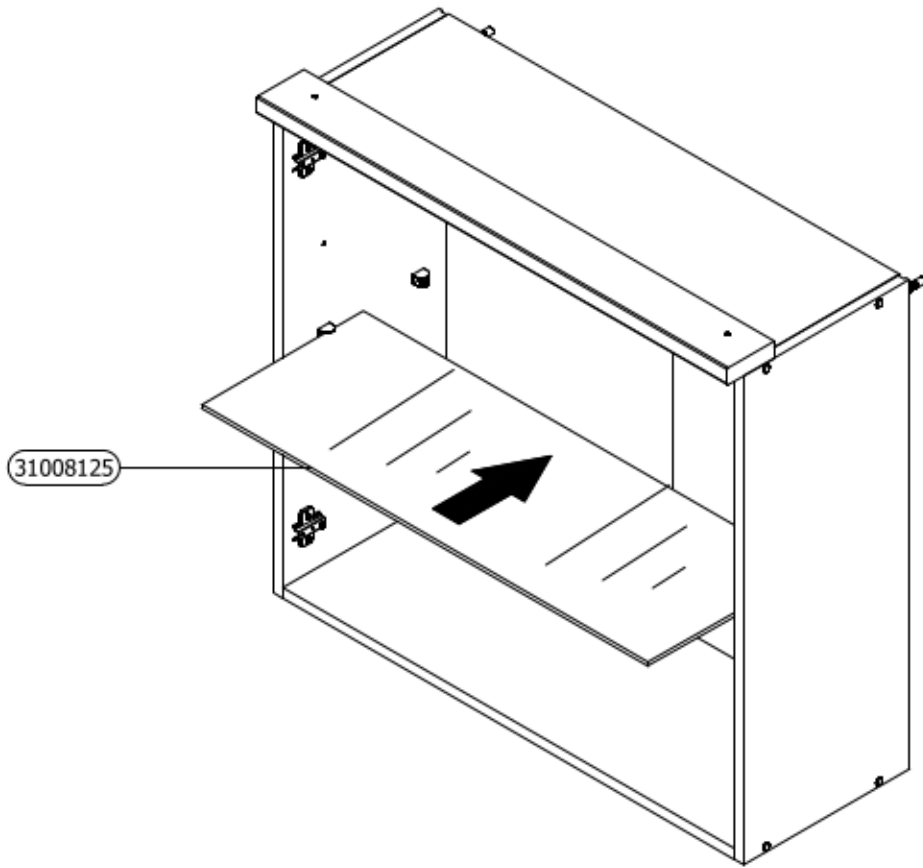

69

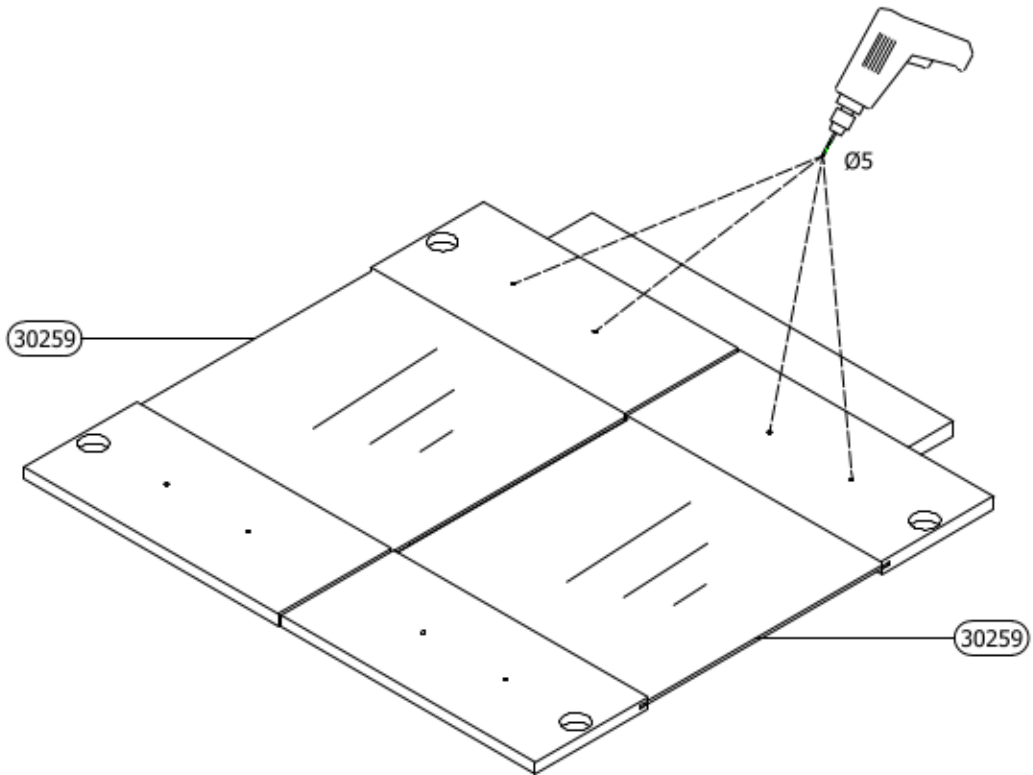

70

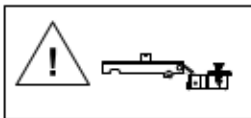
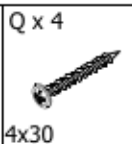
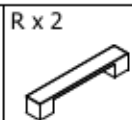
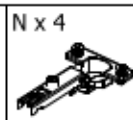

30259

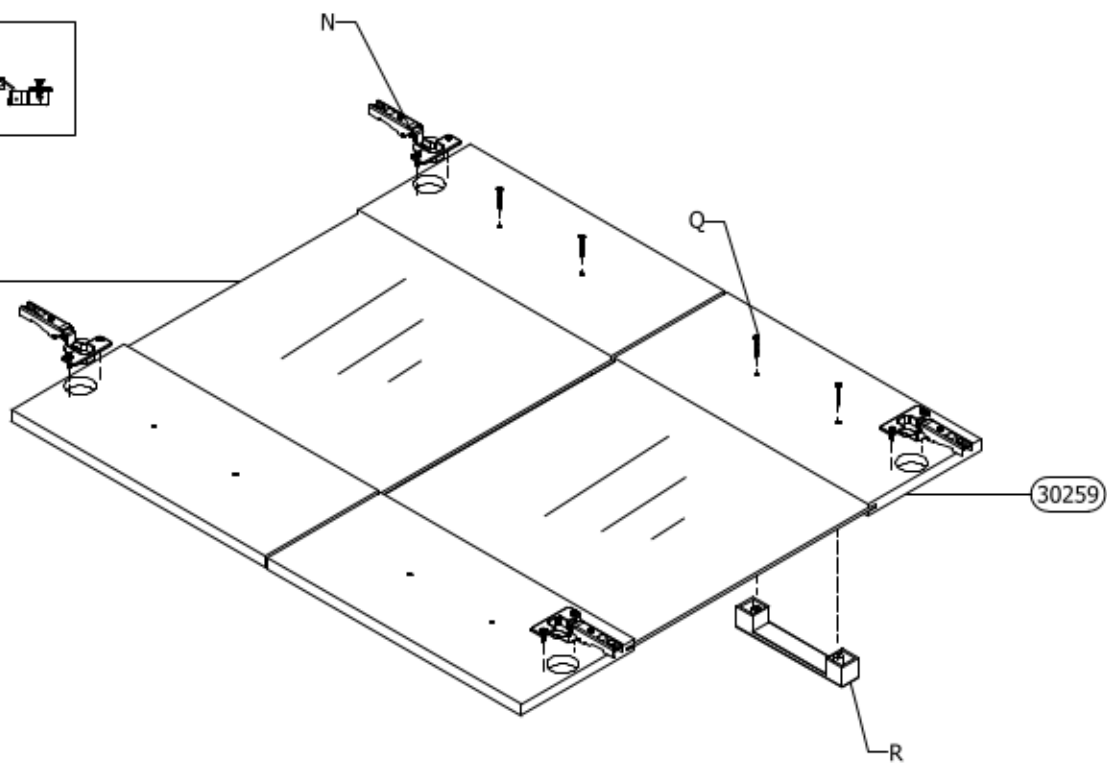

71

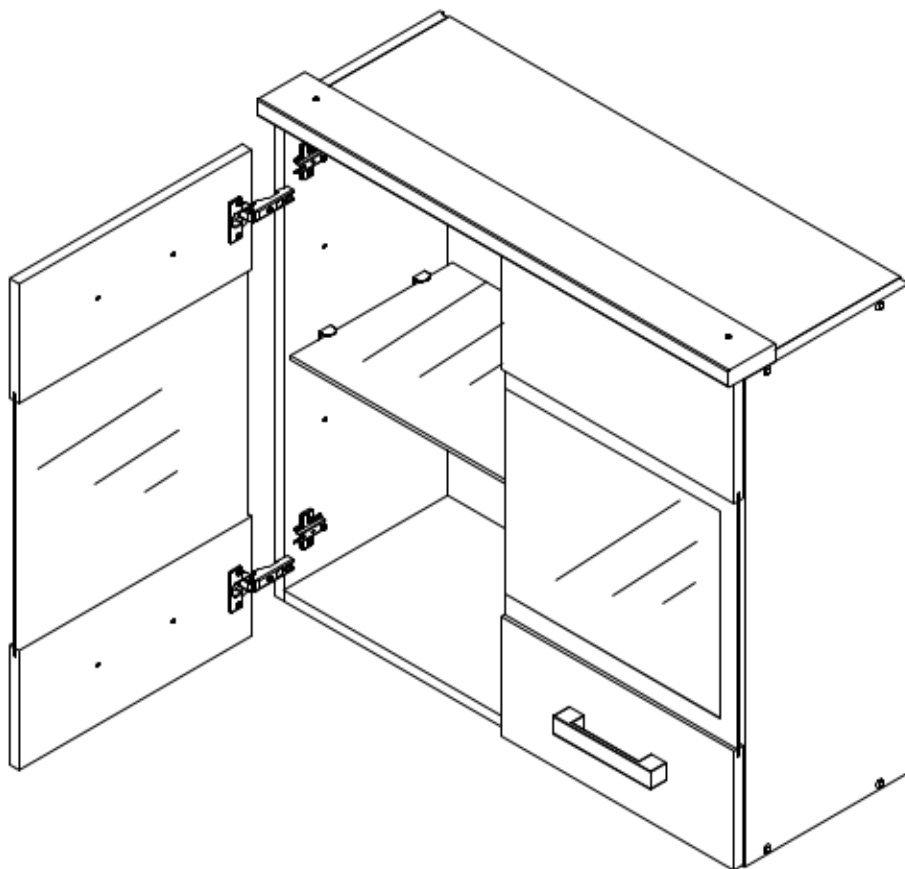

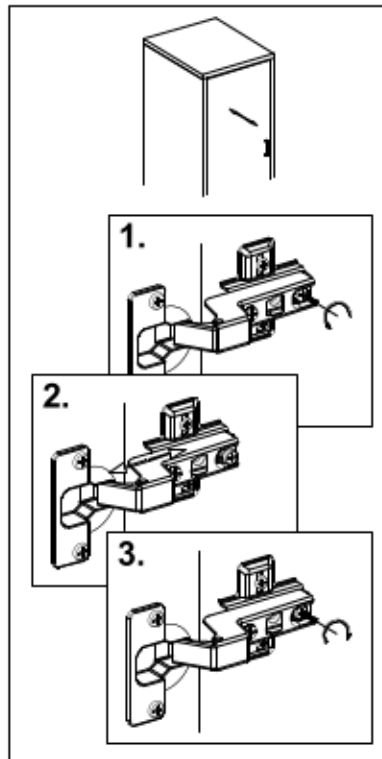
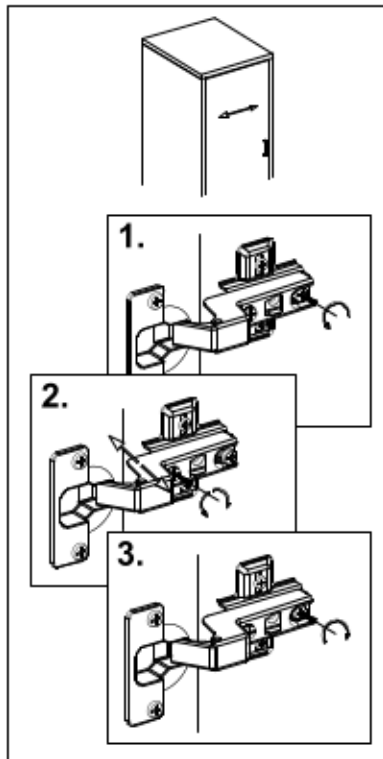
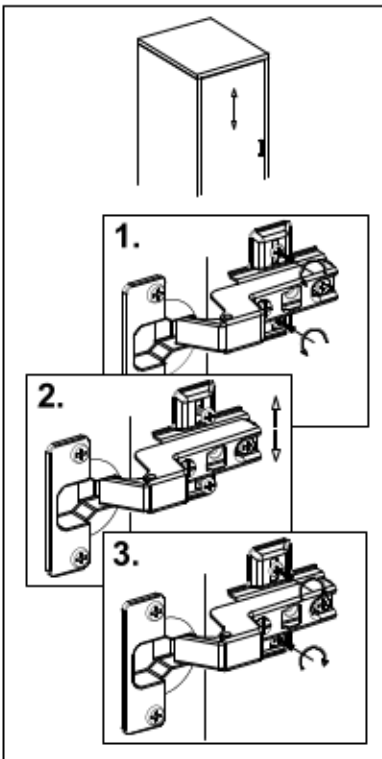
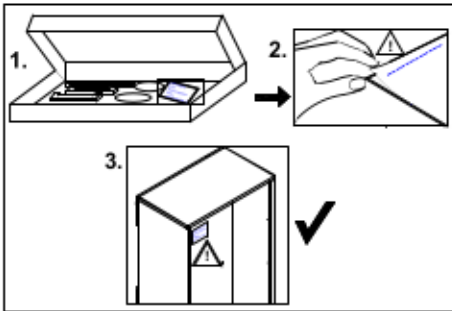
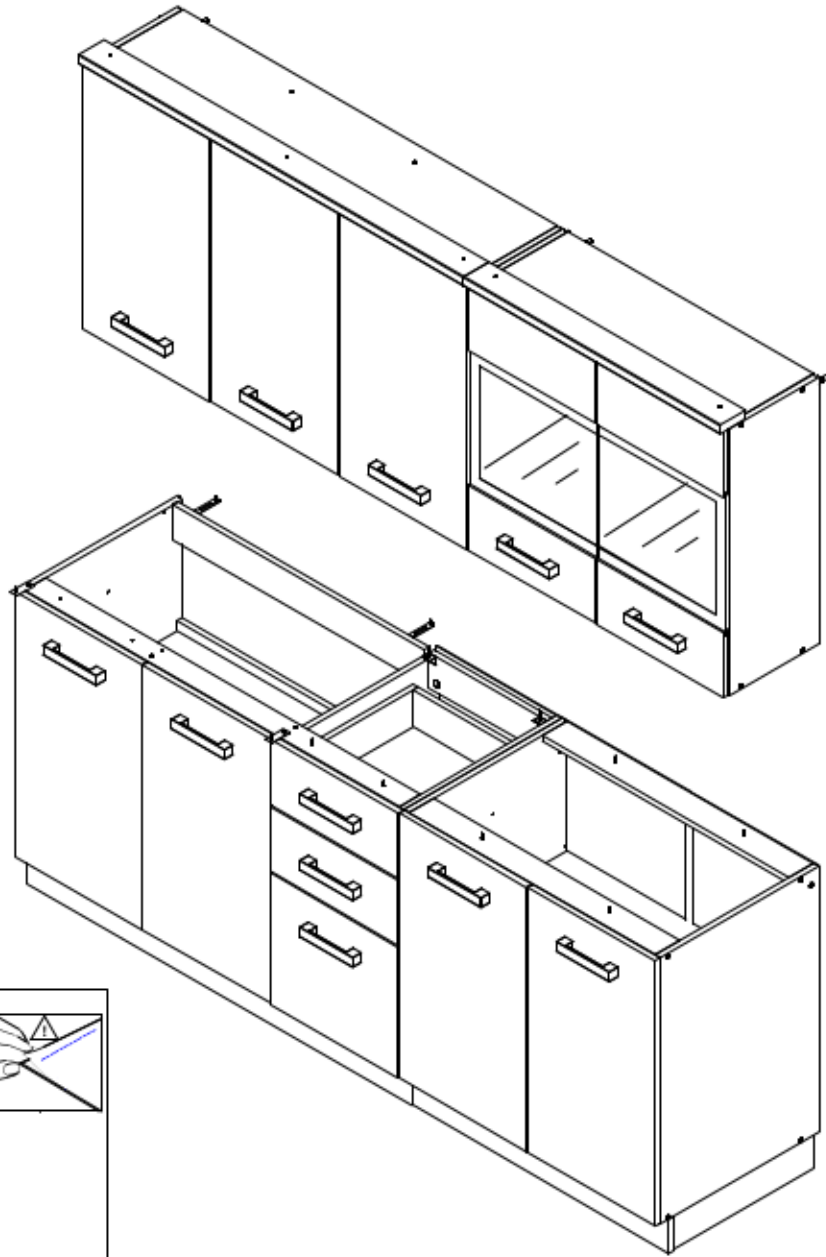



RS ME - UPOZORENJE! Poštovani kupci, kako bi izbegli moguće štete i povrede usled pada proizvoda, molimo Vas da se pridržavate uputstva za pričvršćivanje proizvoda za zid.

UK - ATTENTION! Dear customers, in order to avoid possible damages and injuries due to the fall of the product, please observe the assembly instructions for fixing the products to the wall.

DE AT CH - KIPPSICHERUNG! Sehr geehrte Kunden, um mögliche Schäden und Verletzungen durch den Fall des Produktes zu vermeiden, beachten Sie bitte die Montageanleitung zur Befestigung der Produkte an der Wand.

CZ - UPOZORNĚNÍ! Vážení kupci, abyste předešli možnému poškození a zranění v důsledku pádu výrobku, prosíme, dodržujte pokyny pro upevnění výrobku na zeď.

ES - ATENCIÓN! Estimados clientes, a fin de evitar posibles daños y lesiones debido a la caída del producto, le rogamos que siga las instrucciones para fijar el producto a la pared.

RUS BLR - ВНИМАНИЕ! Уважаемые покупатели, во избежание возможного ущерба и повреждения вследствие падения продукта просим Вас соблюдать инструкцию по прикреплению продуктов к стене.

EL - ΠΡΟΣΟΧΗ! Αξιότιμοι πελάτες, προκειμένου να αποφύγετε τυχόν ζημιές και τραυματισμούς από την πτώση του προϊόντος, σας παρακαλούμε να ακολουθήσετε τις οδηγίες για επάρωση του προϊόντος στον τοίχο.

BG - ВНИМАНИЕ! Уважаеми клиенти, за да избегнете евентуални повреди и наранявания, причинени от падането на продукта, спазвайте инструкциите за закрепване на продукта към стената.

SL - POZOR! Spoštovani kupci, da bi se izognili morebitnim škodam in poškodbam zaradi padca izdelka, vas prosimo, da upoštevate navodila za pritrjevanje izdelka na steno.

MK - ВНИМАНИЕ! Почитувани култивачи, за да ги избегнете можните штети и повреди предизвикани од пад на производот, Ве молиме да ги почитувате упатствата за прицврстување на производот на ѕид.

PL - UWAGA! Szanowni Klienci, w celu uniknięcia ewentualnych obrażeń ciała spowodowanych spadającymi przedmiotami, należy przestrzegać instrukcji mocowania produktu do ściany.

IT - ATTENZIONE! Gentili clienti, al fine di evitare eventuali danni o incidenti causati dalla caduta dei prodotti, siete pregati di seguire le istruzioni in merito alle modalità di affissione del prodotto sul muro.

SK - POZOR! Vážení zákazníci, aby ste predišli možnému poškodeniu a poraniamim v dôsledku spadnutia výrobku, dodržiavajte prosíme Vas pokyny na upevnenie výrobku na stenu.

RO - ATENȚIE! Dragi clienți, pentru a evita posibile pagube și vătămări datorită căderii produsului, vă rugăm să respectați instrucțiunile pentru fixarea produsului pe perete.

HR BIH - OPREZI! Poštovani kupci, kako bi se izbjegle moguće štete i ozljede uslijed pada proizvoda, pridržavajte se uputa za pričvršćivanje proizvoda na zid.

HU - FIGYELEM! Tisztelt vásárlók, a termék leesése következtében keletkezendő esetleges károk és sérülések elkerülése érdekében, kérjük, tartsák be a termék falra erősítésére szolgáló utasításokat.

AL - KUJDES! Klientë të dashur, me qëllim për të parandaluar dëmtime dhe lëndime të mundshme si pasojë e rënies së produktit, ju lutemi që të respektoni udhëzimet për fiksimin e produktit në mur.

PT - ATENÇÃO! Estimados clientes, Para evitar possíveis danos e ferimentos devido à queda do produto, siga as instruções para fixar o produto na parede.

NL BE - WAARSCHUWING! Geachte klanten om mogelijke schade en letsel als gevolg van het vallen van het product te voorkomen, volg de instructies voor het bevestigen van het product aan de muur.



RS ME

Dostavljeni plastični tiplovi su namenjeni za ugradnju na standardan zid od cigle.
Pre ugradnje korisnik je dužan da provjeri da li dostavljeni tiplovi odgovaraju vrsti zida na koji je predviđena ugradnja.
Ukoliko tiplovi ne odgovaraju zidu kupac je u obavezi da u specijalizovanoj radnji sam nabavi odgovarajuće tiplove.

DE AT CH
Die gelieferten Plastikdübel sind zum Einbau in die standardmäßige Ziegelwand bestimmt.
Vor dem Einbau ist der Benutzer verpflichtet zu prüfen, ob die gelieferten Dübel der für den Einbau vorgesehenen Wandart entsprechen.
Wenn die Dübel der Wand nicht entsprechen, ist der Kunde verpflichtet, im Fachhandel entsprechende Dübel selbst zu besorgen.

ES
Las clavijas plásticas que se incluyen están previstas para ser insertadas en un muro de ladrillo estándar.
Antes de instalarlas, el usuario debe verificar si las clavijas proporcionadas son adecuadas para el tipo de muro previsto en que se propone insertarlas.
Si las clavijas no son adecuadas para el muro, el comprador debe adquirir por sí mismo las clavijas correspondientes en una tienda especializada.

RUS BLR
Входящие в комплект поставки пластиковые дюбели предназначены для монтажа на стандартную кирпичную стену.
До начала монтажа пользователь должен проверить соответствие поставленных дюбелей типу стены, на которую предусмотрен монтаж.
Если дюбели не соответствуют типу стены, покупатель должен в обязательном порядке приобрести соответствующие дюбели в специализированном магазине.

EL
Οι πλαστικές βίδες που παρέχονται προορίζονται για ενσωμάτωση σε συνήθισμένο τοίχο από τούβλα.
Πριν από την ενσωμάτωση, ο χρήστης οφείλει να ελέγξει εάν οι βίδες που παρέχονται αντιστοιχούν στον τύπο του τοίχου στον οποίο προβλέπεται η ενσωμάτωση.
Εάν οι βίδες δεν ταιριάζουν στον τοίχο, ο αγοραστής υποχρεούται να προμηθευθεί κατάλληλες σε εξειδικευμένο κατάστημα.

BG
Доставените пластмасови дюбели са направени за вграждане в стандартна тухлена стена. Преди вграждането, ползувателят е длъжен да провери дали доставените дюбели съответстват на стената, за която са предвидени за вграждане. Ако дюбелите не съответстват на стената на културна, то той задължително трябва да закупи съответни дюбели от специализирания магазин.

SL
Dostavljeni plastični nosilci so namenjeni za montažo na standardni zid iz opeke. Pred montažo je uporabnik dolžan preveriti, ali dostavljeni nosilci ustrezajo vrsti zidu, na katerem je predvidena montaža. V kolikor nosilci niso primerni, je kupec dolžan sam pri specializiranemu prodajalcu priskrbiti nosilce, ki ustrezajo montaži.

MK
Доставените пластични типли наменети се за прикачување на стандарден ѕид од цигла. Пред прикачувањето корисникот е должен да провери дали доставените типли одговараат на ѕидот на кој е предвидено прикачувањето. Доколку типлите не одговараат култивачот е должен сам да набави во специјализирана продавница типли кои одговараат.

PL
Dołączone plastikowe kolki są przeznaczone do montażu na standardową ścianę z cegły.
Przed zamontowaniem, użytkownik jest zobowiązany upewnić się, czy załączone kolki odpowiadają typowi ściany na której jest przewidziany montaż.
W przypadku gdy kolki nie są odpowiednie do typu ściany, na którą ma być zamontowany regał, użytkownik jest zobowiązany, aby samemu zaopatrzyć się w odpowiedni typ kolków w sklepie specjalistycznym.

NL BE
Geleverde plastic pluggen zijn bedoeld voor montage op een standaard bakstenen muur.
Voor montage dient de koper te controleren of de geleverde pluggen geschikt zijn voor de voorziene muur. Als de pluggen niet geschikt zijn voor de muur, moeten kopers een gespecialiseerde winkel bezoeken en zelf geschikte pluggen kopen.



UK

Delivered plastic plugs are intended for fitting on a standard brick wall.
Before fitting, the buyer needs to check if the delivered plugs are suitable for the wall they are foreseen for.
If the plugs are not suitable for the wall, buyers have to visit a specialized store and get suitable plugs by themselves.

IT CH
I tasselli di plastica consegnati sono destinati al montaggio su un muro di mattoni standard.
Prima del loro montaggio, l'acquirente deve controllare se i tasselli forniti sono adatti per la parete su cui si prevede di installarli.
Se i tasselli non sono adatti per questo tipo di parete, l'acquirente è tenuto ad acquistare i tasselli adeguati presso un negozio specializzato.

FR CH
Les chevilles en plastique fournies sont conçues à l'installation sur le mur standard en briques.
Avant l'installation, l'utilisateur est obligé à vérifier si les chevilles fournies correspondent bien au type de mur prévu pour l'installation.
Si les chevilles ne correspondent pas bien au mur, l'acheteur est obligé à assurer lui-même les chevilles correspondantes dans un magasin spécialisé.

CZ SK
Dodané plastové hmoždinky jsou určeny pro montáž na standardní cihlovou stěnu. Před začátkem montáže, kupující je povinen dohlédnout na správnost typu dodaných hmoždinek, vzhledem na typ stěny určené k montáži.
Pokud hmoždinky dodané výrobcem neodpovídají typu stěny určené k montáži, kupující je povinen pořídit si správný typ ve specializované prodejně.

RO
Tiplurile din plastic transmise sunt prevăzute exclusiv pentru pereți standard din cărămidă.
Înainte de instalare beneficiarul este obligat să verifice dacă tiplurile transmise corespund peretelui pe care se prevede instalarea. În cazul în care tiplurile nu corespund peretelui, cumpărătorul este obligat să achiziționeze singur tiplurile corespunzătoare din magazinele specializate.

HR BIH
Dostavljeni plastični tiplovi su namijenjeni za ugradnju na standardan zid od cigle. Prije ugradnje korisnik je dužan da provjeri da li dostavljeni tiplovi odgovaraju vrsti zida na koji je predviđena ugradnja.
Ukoliko tiplovi ne odgovaraju zidu kupac je u obavezi da u specijaliziranoj radnji sam nabavi odgovarajuće tiplove.

HU
A kézbesített műanyag tiplik standard téglafalra való beépítésre szolgálnak. Beépítés előtt a felhasználó köteles leellenőrizni, hogy a tiplik megfelelnek-e a falajtájának, amelyre a beépítést szánták.
Ha a tiplik nem felelnek meg, a vásárló köteles a megfelelőket szaküzletben beszerezni.

AL
Ankorat e dhëna plastike janë të dizajnuara për instalim në mur standard me tullë. Para instalimit përdoruesi duhet të verifikojë nëse ankorat e dërguara iu përshatën llojit të murit në të cilin është parashikuar të bëhet instalimi.
Nëse ankorat nuk iu përshatën murit, blerësi është i obliguar që vetë të blejë ankorat e duhura në shitoren e specializuar.

PT
As buchas plásticas fornecidas destinam-se à instalação numa parede de tijolos padrão.
Antes da instalação, é obrigado a verificar se as buchas fornecidas correspondem ao tipo de parede em que instalação está prevista.
Se as buchas não forem as mais indicadas à parede, será da responsabilidade do cliente a compra das buchas apropriadas em uma loja especializada.