

UPUTSTVO ZA MONTIRANJE  
ASSEMBLING INSTRUCTION  
MONTAGEANLEITUNG  
INSTRUCTIONS D'ASSEMBLAGE  
INSTRUCCIONES DE MONTAJE

ISTRUZIONI PER L'INSTALLAZIONE  
ИНСТРУКЦИЯ ПО МОНТАЖУ  
MONTÁŽNÍ NÁVOD  
ΟΔΗΓΙΕΣ ΣΥΝΑΡΜΟΛΟΓΗΣΗΣ  
INSTRUCȚIUNI DE MONTAJ

ИНСТРУКЦИЯ ЗА МОНТАЖ  
SZERELÉSI UTASÍTÁS  
NAVODILA ZA MONTAŽO  
UPUTE ZA MONTAŽU  
UPUTSTVO ZA MONTIRANJE

УПАТСТВО ЗА МОНТИРАЊЕ  
UDHËZIMET PËR MONTIM  
INSTRUKCJA MONTAŻU  
INSTRUÇÕES DE MONTAGEM  
MONTAGE INSTRUCTIE

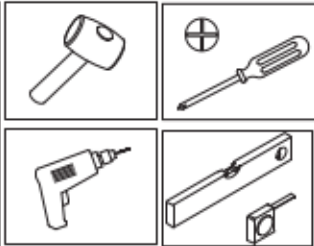
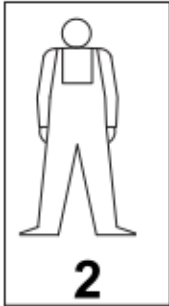

\* **RS ME** Naznačeno vreme montaže važi za stručno obučena lica (profesionalne montažere)/**UK** The specified installation time applies to professionally trained persons (professional installers)/**DE AT CH** Die bezeichnete Zeit der Montage gilt für fachlich geschulte Personen (professionelle Monteure) / **FR CH** Le temps d'installation spécifique s'applique aux personnes formées professionnellement (installateurs professionnels) / **ES** El tiempo de instalación especificado se refiere a personas profesionalmente capacitadas (instaladores profesionales) / **IT CH** tempo di installazione indicato vale per le persone professionalmente preparate (installatori professionali) / **RUS** Приведённое время монтажа действительно для специально обученных лиц (профессиональных монтажников) / **CZ** Uvedená doba montáže se vztahuje na odborně způsobilé osoby (profesionální montér) / **EL** Ο αναφερόμενος χρόνος εγκατάστασης ισχύει για εκπαιδευμένα άτομα (επαγγελματίες εγκαταστάτες) / **RO** Timpul de instalare specificat se aplică persoanelor instruite profesional (instalatori profesioniști) / **BG** Посоченото време за монтаж се отнася за професионално обучени лица (професионални монтажници) / **HU** Az összeszerelés megjelölt ideje a szakképzett személyekre vonatkozik (hivatásos összeszerelők) / **SL** Navedeni čas namestitve (montaže) velja za strokovno usposobljene osebe (strokovne monterje) / **HR** Navedeno vrijeme montaže odnosi se na stručno osposobljene osobe (profesionalne montažere) / **BIH** Naznačeno vrijeme montaže važi za stručno obučena lica (profesionalne montažere) / **MK** Назначеното време за монтажа важи за стручно обучени лица (професионални монтажери) / **AL** Koha e specifikuar e instalimit zbatohet në rast të personave me trajnim profesional (instalues profesionistë) / **PL** Znaczyony czas montażu dotyczy przeszkolonych zawodowo osób (profesjonalnych monterów) / **PT** O tempo de montagem indicado aplica-se a pessoas profissionalmente treinadas (instaladores profissionais) / **NL BE** De aangegeven installatietijd is geldig voor professioneel opgeleide personen (professionele installateurs).

**RS ME** PRE POČETKA MONTIRANJA OBAVEZNO PROČITAJTE UPUTSTVO ZA MONTAŽU / **UK** BEFORE STARTING, REFER TO THE ASSEMBLING ADVICE IN ANNEX / **DE AT CH** VOR DER MONTAGE BITTE BEILIEGENDE ANWEISUNGEN LESEN / **FR CH** AVANT LE DÉBUT DE L'ASSEMBLAGE, S'IL VOUS PLAÎT, LISEZ L'INSTRUCTION D'ASSEMBLAGE / **ES** ANTES DE EMPEZAR EL MONTAJE, LEER CUIDADOSAMENTE LAS INSTRUCCIONES DEL ANEXO / **IT CH** PRIMA DI INIZIARE L'INSTALLAZIONE SI RACCOMANDA DI LEGGERE LE ISTRUZIONI DI INSTALLAZIONE / **RUS** ДО НАЧАЛА МОНТАЖА ОЗНАКОМЬТЕСЬ С ИНСТРУКЦИЕЙ / **CZ** SEZNAMTE SE S NÁVODEM PŘED MONTÁŽÍ NÁVYTKU / **EL** ΠΡΙΝ ΞΕΚΙΝΗΣΕΤΕ ΤΗ ΣΥΝΑΡΜΟΛΟΓΗΣΗ, ΟΠΩΣΔΗΠΟΤΕ ΔΙΑΒΑΣΤΕ ΤΙΣ ΟΔΗΓΙΕΣ ΣΥΝΑΡΜΟΛΟΓΗΣΗΣ / **RO** ÎNAINTE DE ÎNCERPEREA MONTAJULUI ESTE OBLIGATORIE CITIREA INSTRUCȚIUNILOR / **BG** ПРЕДИ МОНТИРАНЕ НЕ ЗАБРАВЯЙТЕ ДА С К ЧЕТЕ ИНСТРУКЦИИ ЗА МОНТАЖ / **HU** SZERELÉS ELŐTT OKVETLENÜL OLVASSA EL A HASZNÁLATI UTASÍTÁST / **SL** PRED ZAČETKOM MONTAŽE OBEVZNO PREBERITE NAVODILA / **HR** PRIJE MONTAŽE UPOZNATI SE SA UPUTSTVOM / **BIH** PRE POČETKA MONTIRANJA OBAVEZNO PROČITAJTE UPUTSTVO ZA MONTAŽU / **MK** ПРЕД ПОЧЕТОК НА МОНТИРАЊЕ ЗАДОЛЖИТЕЛНО ДА СЕ ПРОЧИТА УПАТСТВОТО ЗА МОНТИРАЊЕ / **AL** PARA FILLIMIT TË MONTIMIT LEXONI PATJETËR UDHËZIMIN PËR MONTIM / **PL** PRZED ROZPOCZĘCIEM MONTAŻU PROSZĘ ZAPOZNAĆ SIĘ Z INSTRUKCJĄ / **PT** ANTES DE INICIAR A MONTAGEM, CERTIFIQUE-SE DE LER AS INSTRUÇÕES DE MONTAGEM / **NL BE** LEES DE MONTAGE INSTRUCTIE VOORDAT U MET DE INSTALLATIE BEGINT

V1

V2

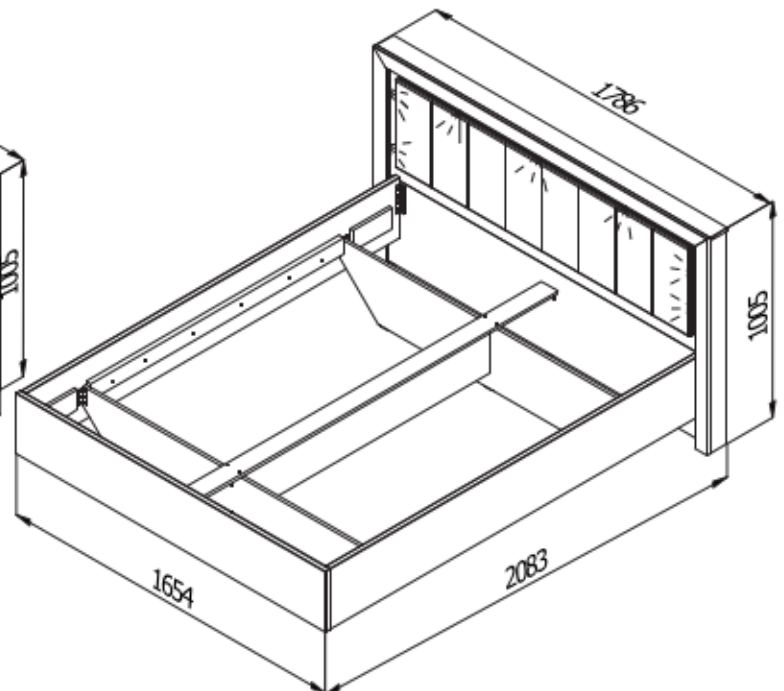
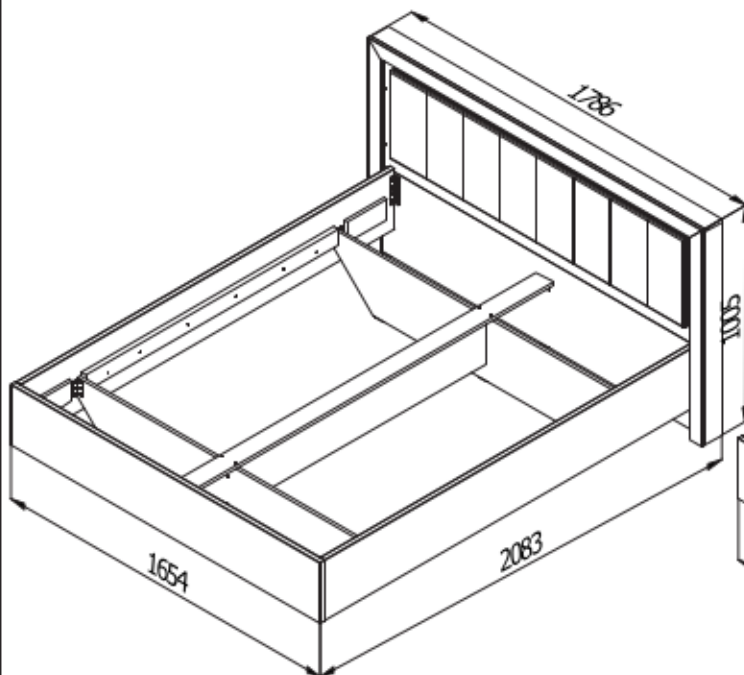

29355	1350 mm	76 mm	25 mm	2
29357	1600 mm	296 mm	16 mm	2
29358	1356 mm	220 mm	16 mm	1
29359	2000 mm	90 mm	16 mm	1
30094	1750 mm	400 mm	16 mm	1
30095	1750 mm	584 mm	16 mm	1
30096	2000 mm	280 mm	25 mm	2
30097	1654 mm	280 mm	25 mm	1
30971	984 mm	92 mm	16 mm	2
30972	1784 mm	92 mm	16 mm	1
30973	1002 mm	66 mm	16 mm	1
30974	1002 mm	66 mm	16 mm	1
30975	1786 mm	66 mm	16 mm	1
31013035	1574 mm	405 mm	41 mm	1
33593	210 mm	95 mm	16 mm	4

Package 1/3	
29355	2
29359	1
30096	2
33593	4

Package 2/3	
29357	2
29358	1
30094	1
30095	1
30097	1
30971	2
30972	1
30973	1
30974	1
30975	1

Package 3/3	
31013035	1

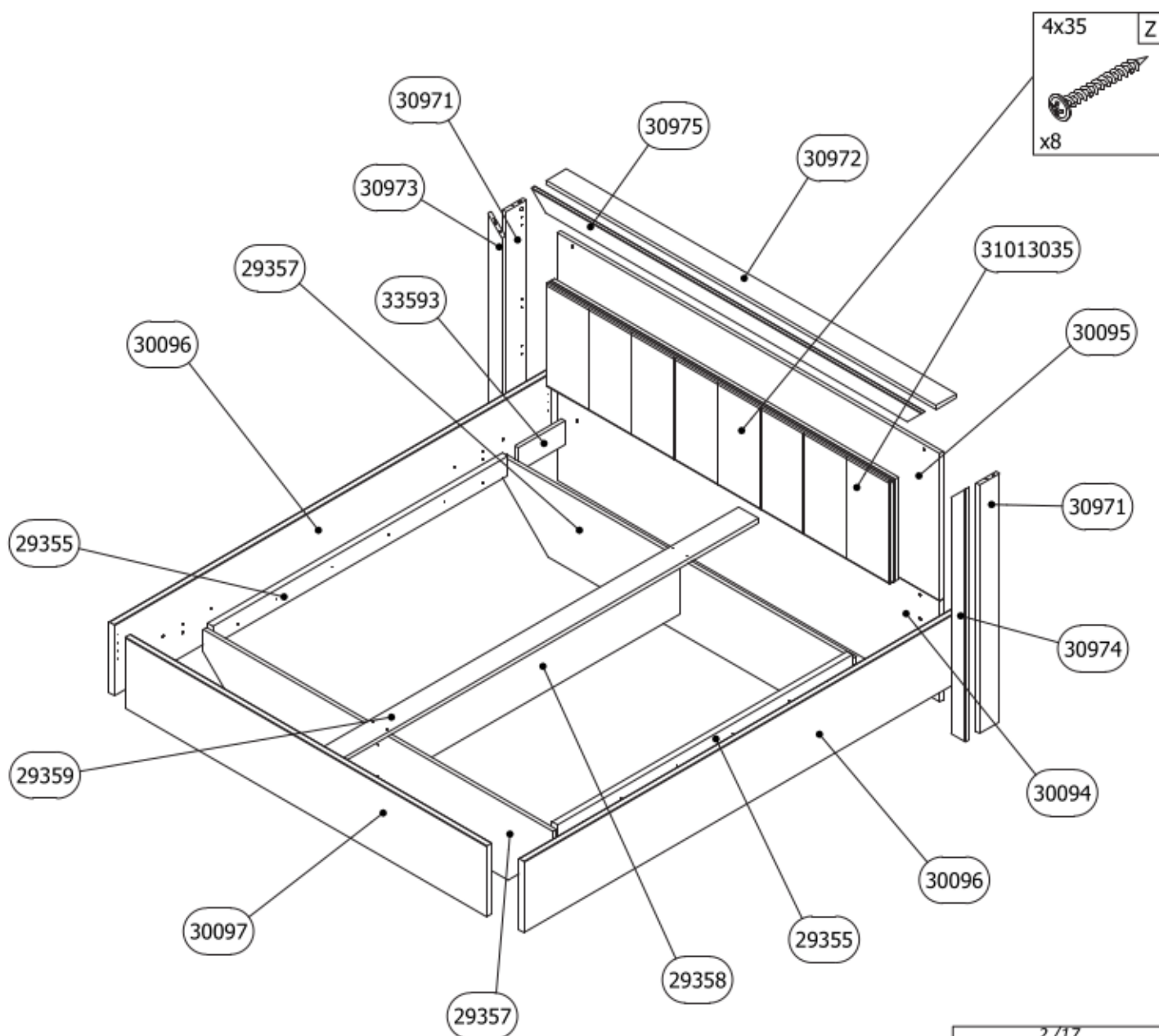

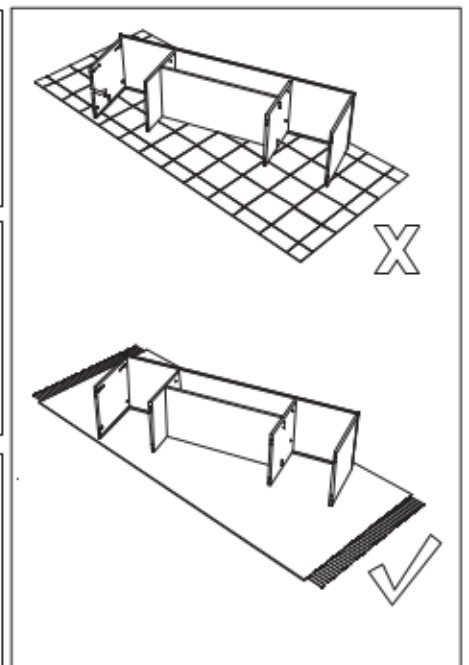
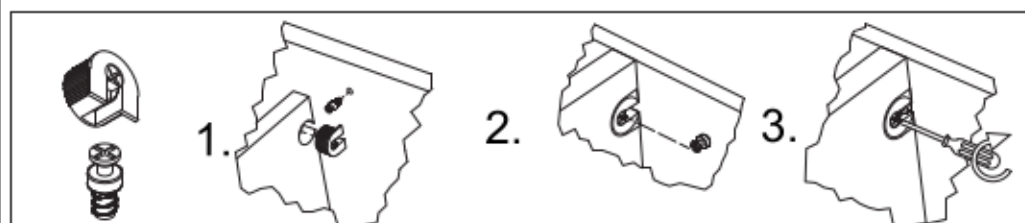
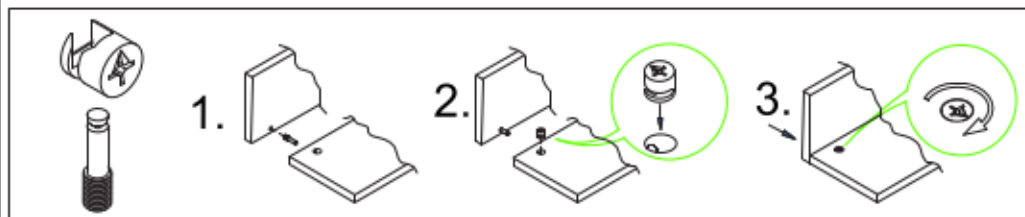
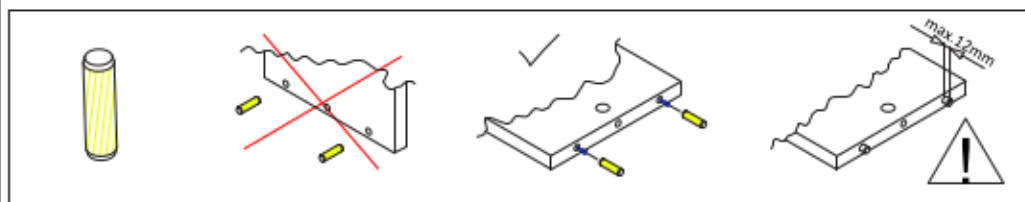

<p><b>RS ME</b></p> <p>1. Montažu obavljati na čistoj i mekoj podlozi (karton, tkanina...)  2. Da bi izbegli oštećenja elemenata pridržavati se datih instrukcija.  3. Prilikom prijave reklamacije koristiti date oznake elemenata.</p>	<p><b>FR CH</b></p> <p>1. Effectuer l'assemblage sur une surface propre et douce (carton, tissu...)  2. Afin d'éviter l'endommagement des éléments, respectez les instructions données.  3. Lors de l'application de réclamation, utiliser les désignations données des éléments.</p>
<p><b>DE AT CH</b></p> <p>1. Die Montage soll auf sauberer, weicher Fläche durchgeführt werden (Karton, Stoff)  2. Um die Beschädigung der Elemente zu vermeiden, befolgen Sie bitte die angegebenen Instruktionen  3. Bei Reklamationsmeldungen benutzen Sie bitte die angegebenen Kennzeichen der Elemente</p>	<p><b>UK</b></p> <p>1. Assembly of the product should be done on a clean and soft surface (cardboard, fabric)  2. To prevent damage of the product, it is necessary to adhere to the assembly instructions  3. While reporting defective products, please quote codes in manual</p>
<p><b>ES</b></p> <p>1. Realizar el montaje sobre una superficie limpia y suave (cartón, paño)  2. Para evitar daños del producto, atenerse a las instrucciones de montaje  3. Para reportar productos defectuosos, refiérase por favor a los códigos del manual</p>	<p><b>IT CH</b></p> <p>1. Eseguire l'installazione su una base morbida (cartone, tessuto).  2. Seguire le istruzioni per evitare di causare danni agli elementi.  3. In caso della presentazione di reclamo si utilizzano relative indicazioni degli elementi.</p>
<p><b>RO</b></p> <p>1. Montarea se efectueaza pe o suprafata moale și curată (carton, material...)  2. Respectați instrucțiunile pentru a evita deteriorarea pieselor  3. La transmiterea reclamațiilor a se folosi inscripțiile date ale pieselor</p>	<p><b>CZ SK</b></p> <p>1. Montáž provádět na čistém a měkkém podkladu (lepenka, látka)  2. Dodržujte přiložené instrukce, abyste předešli poškození součástí  3. Při reklamaci používejte přiložené označení element</p>
<p><b>EL</b></p> <p>1. Η συναρμολόγηση του προϊόντος πρέπει να γίνει σε καθαρή και μαλακή επιφάνεια (χαρτόνι, ύφασμα).  2. Για να μην φθοραούν τα στοιχεία, συμμορφωθείτε με τις οδηγίες που παρέχονται.  3. Κατά τη δήλωση ελαττωματικού προϊόντος, αναφέρετε τους κώδικες των στοιχείων όπως αναφέρονται στο εγχειρίδιο.</p>	<p><b>RUS BLR</b></p> <p>1. Монтаж изделия выполнять на чистой и мягкой поверхности (картон, ткань)  2. Для предотвращения порчи изделий необходимо придерживаться правил монтажа  3. В случае предъявления претензии использовать данные обозначения элементов.</p>
<p><b>BG</b></p> <p>1. Монтажът трябва да бъде извършен върху чиста и мека основа /karton, тъкан/  2. За да избегнете оцетяване на елементи, спазвайте дадените инструкции  3. При наличие на reclamaция, използвайте дадените кодове на елементи</p>	<p><b>HU</b></p> <p>1. A szerelés tisztaság és puha felületen (karton, anyag) kell végreajtani.  2. Károsodásnak elkerülése érdekében, tartsa be a megadott utasításokat.  3. Reklamáció esetén hivatkozzon a bútor alkatrészein megadott jelekre.</p>
<p><b>SL</b></p> <p>1. Montažo opravimo na čisti in mehki podlogi (karton, tkanina)  2. Da bi se izognili poškodbam elementov, upoštevajte navodila.  3. Pri reklamaciji uporabimo oznake elementov</p>	<p><b>BIH HR</b></p> <p>1. Montažu obavljati na čistoj i mekoj podlozi (karton, tkanina)  2. Da bi izbegli oštećenja elemenata pridržavati se datih instrukcija  3. Prilikom prijave reklamacije koristiti date oznake elemenata</p>
<p><b>MK</b></p> <p>1. Монтажа да се врши на чиста и мека подлога (karton, ткаенина)  2. За да се избегне оштетување на елементите придржувајте се на дадените инструкции  3. За пријава на рекламици користете ги дадените ознаки на елементите</p>	<p><b>AL</b></p> <p>1. Montimi të bëhet në sipërfaqe të pastër dhe të butë (karton, pëlhurë)  2. Që t'u shmangeni dëmtimit të elementeve, pëmbahuni instrukcioneve të dhëna  3. Me rastin e reklamimit përdorni shenjat e dhëna të elementit</p>
<p><b>PL</b></p> <p>1. Montować należy na czystej i miękkiej powierzchni (karton, tkanina)  2. Aby uniknąć uszkodzenia elementów należy postępować ściśle według instrukcji.  3. Przy zgłaszaniu reklamacji należy posługiwać się załączonymi oznaczeniami elementów.</p>	<p><b>HR</b></p> <p>1. Pažljivo pročitajte upute za montažu  2. Pripremite sve dijelove namještaja  3. Prikupite i provjerite okove za montažu  4. Pripremite potreban alat  5. Pripremite prostor za montažu  6. Počnite montirati  7. Sačuvajte ove ove upute  8. Proizvod je namjenjen isključivo za kućnu uporabu</p>
<p><b>PT</b></p> <p>1. A montagem deve ser feita em uma superfície limpa e macia (papelão, tecido...)  2. Para evitar danos nos elementos, siga as instruções fornecidas.  3. Durante a apresentação de reclamação usar os rótulos dos elementos fornecidos.</p>	
<p><b>NL BE</b></p> <p>1. De installatie moet worden uitgevoerd op een schoon en zacht oppervlak (karton, stof...)  2. Volg de gegeven instructies om schade aan de elementen te voorkomen.  3. Gebruik bij het melden van een klacht de gegeven elementlabels.</p>	





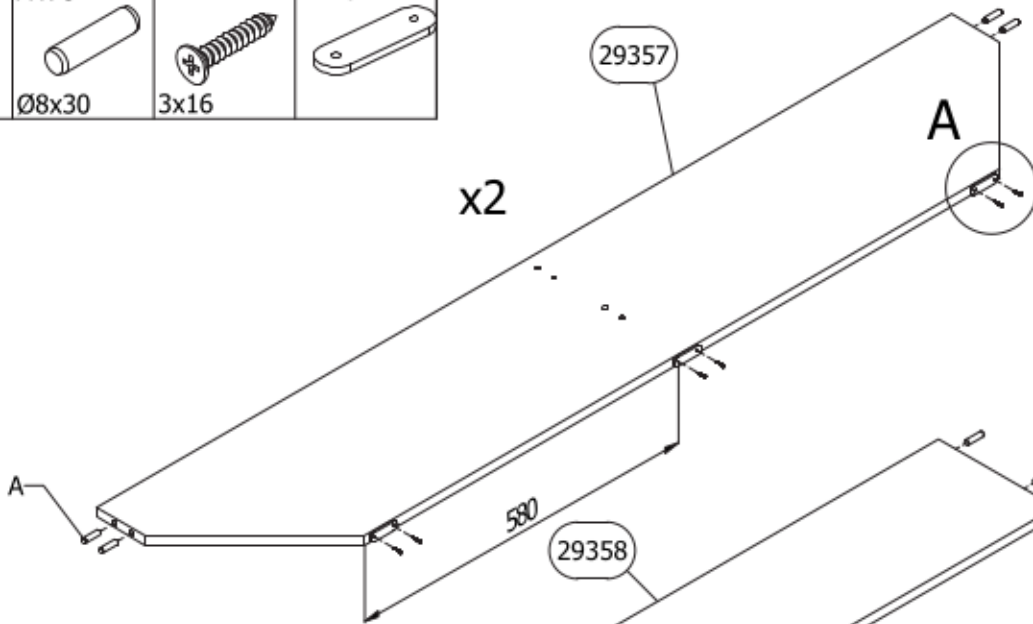

A	∅8x30	B	4x16	C	∅7x50	D	3x16	E		F	4x30	G	4x40	H		I		J	
x22		x84		x5		x18		x9		x4		x8		x8		x8		x12	
K	∅8x60	L		M		N		O	52x48x32	P	∅6.3x13	Q	∅8x50	R		S	52x30x30	T	
x4		x4		x4		x4		x9		x18		x4		x5		x2		x4	
U		V		W	4x16	X		Y	4x30	Z	4x35	Aa		Ab		Ac		Ad	
x8		x4		x22		x11		x8		x8									

<b>1</b>	A x 8	D x 12	E x 6
			
	∅8x30	3x16	

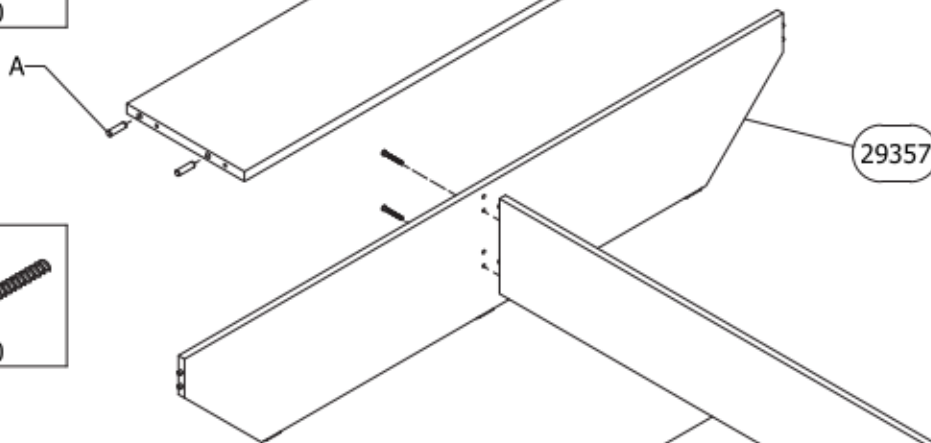

<b>2</b>	A x 4
	
	∅8x30



<b>3</b>	C x 4
	
	∅7x50

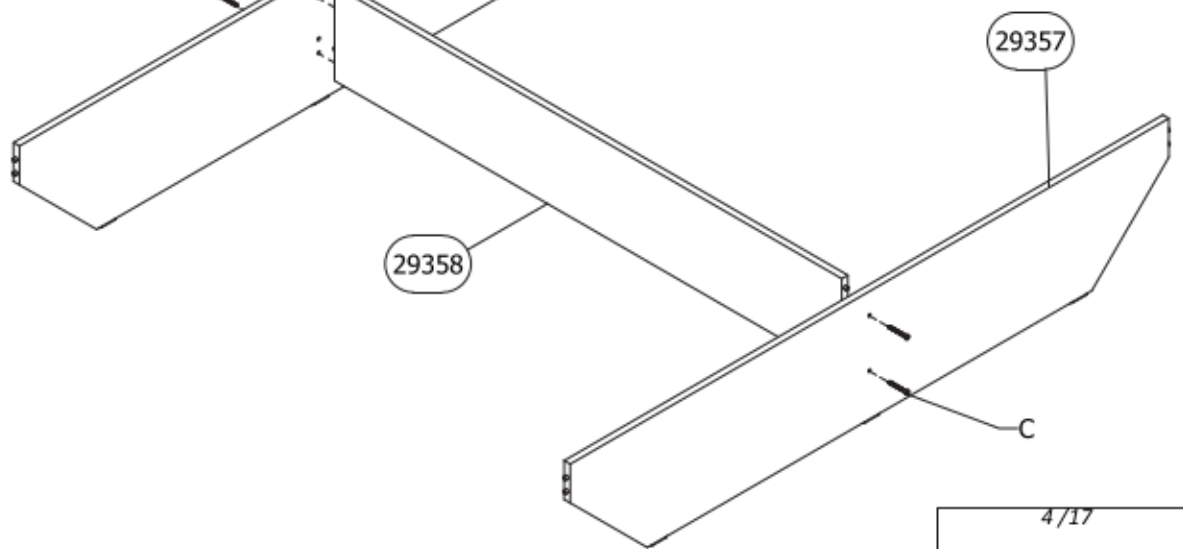

4

A x 4

Ø8x30



A

x2

30096

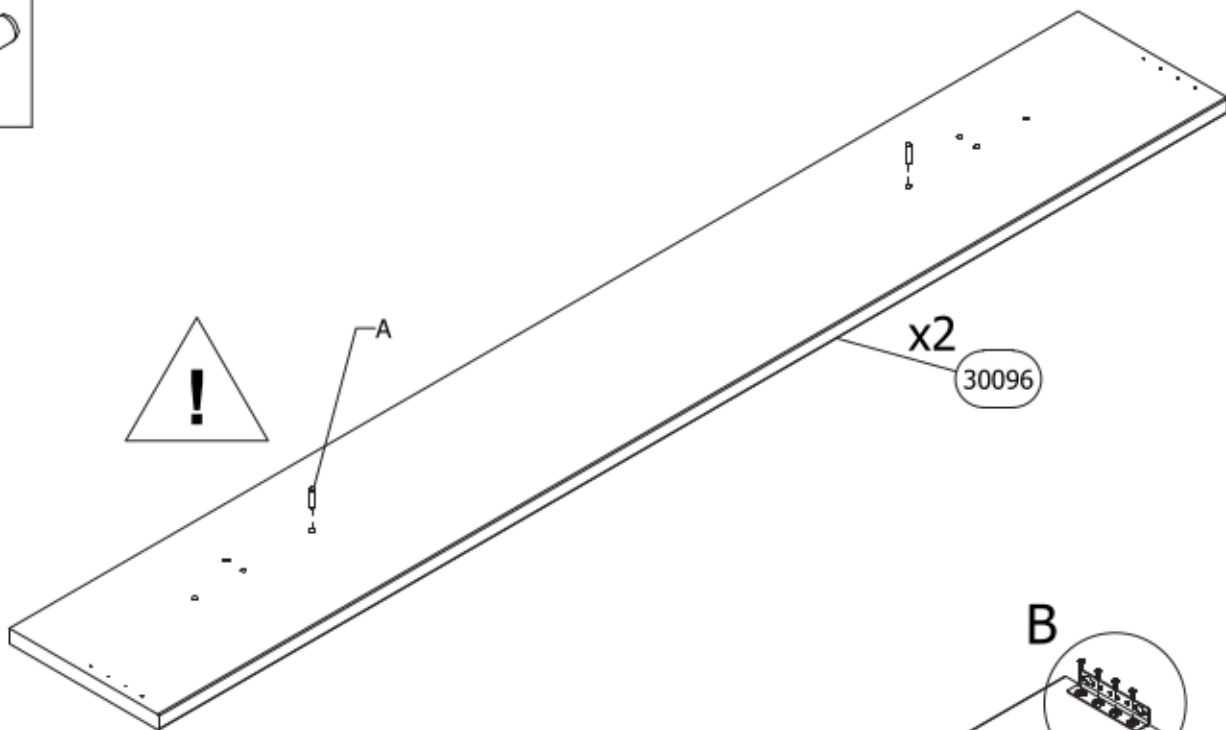

5

B x 16

4x16



G x 8

4x40



M x 4



29355

B

30096

G

x2

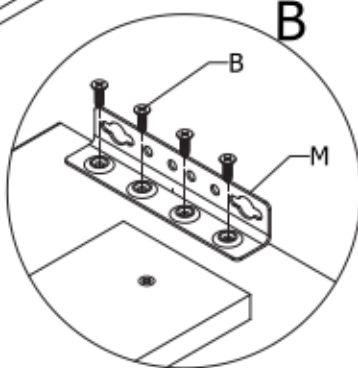
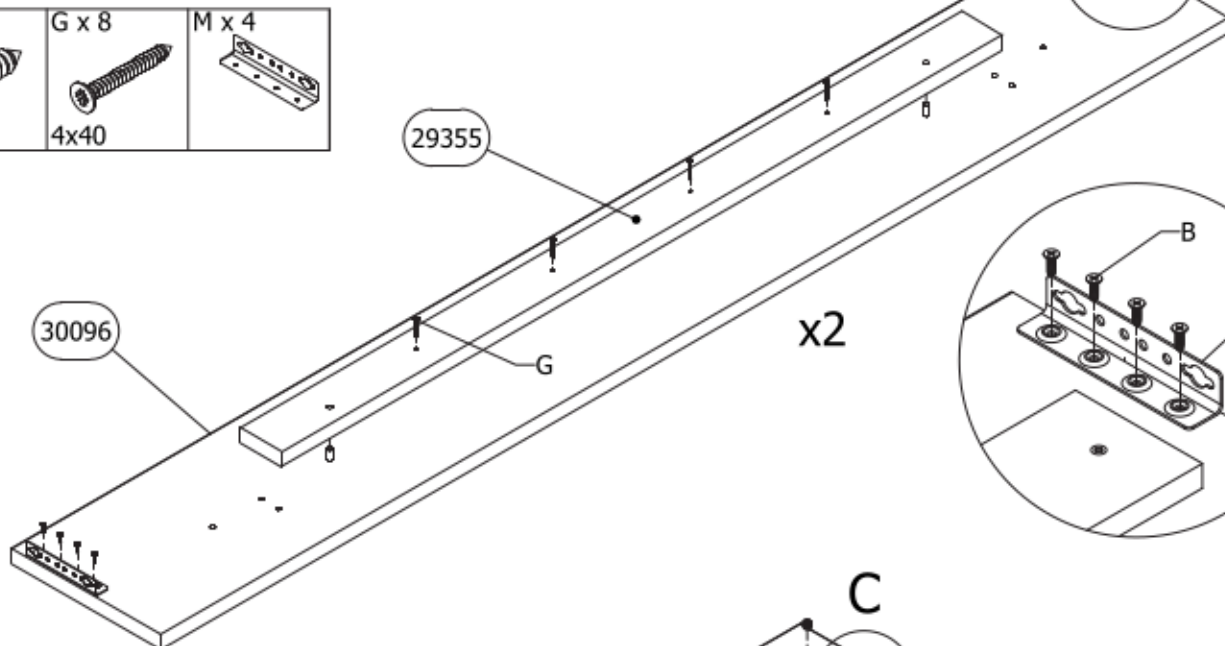

B

M

6

I x 4



H x 4



30097

C

C

I

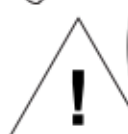

H

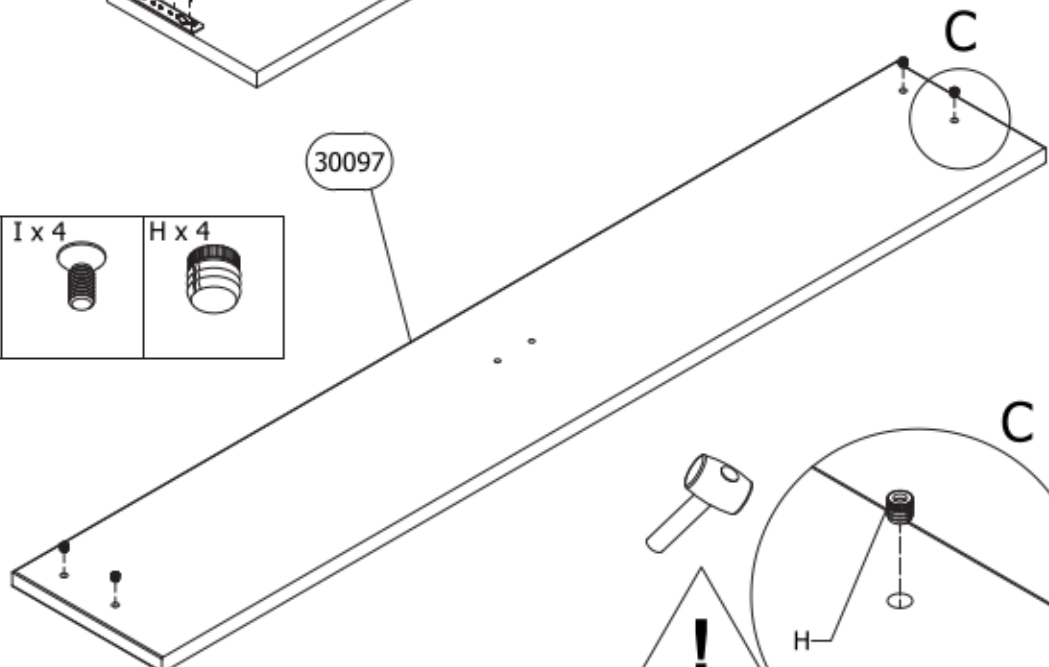

7



105

D

D

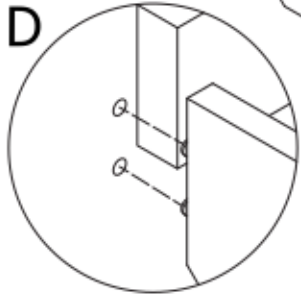

8

N x 4

B x 24



4x16

E

E

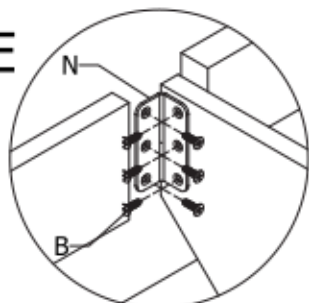

9

B x 4



4x16

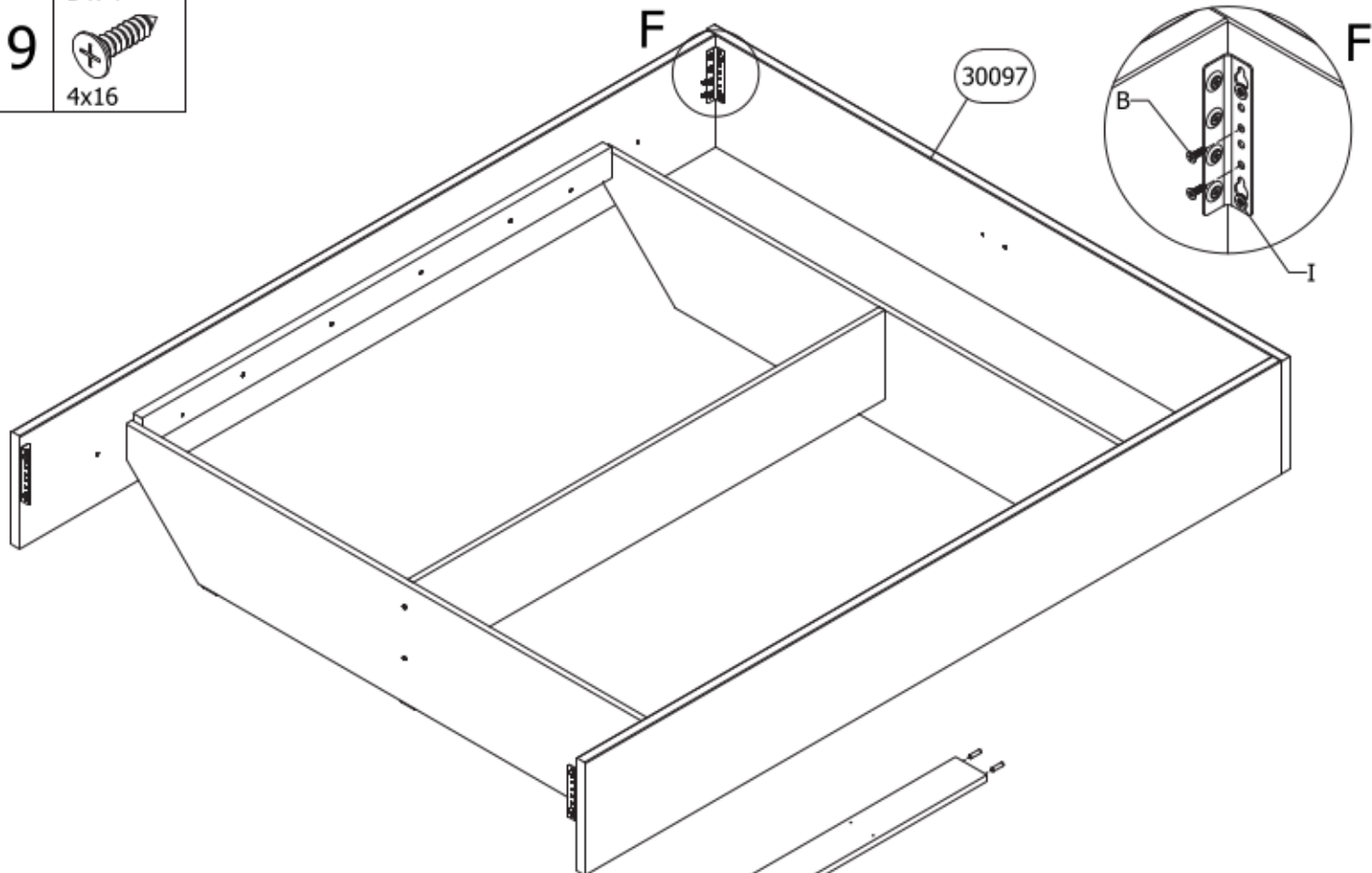

10

A x 4



Ø8x30

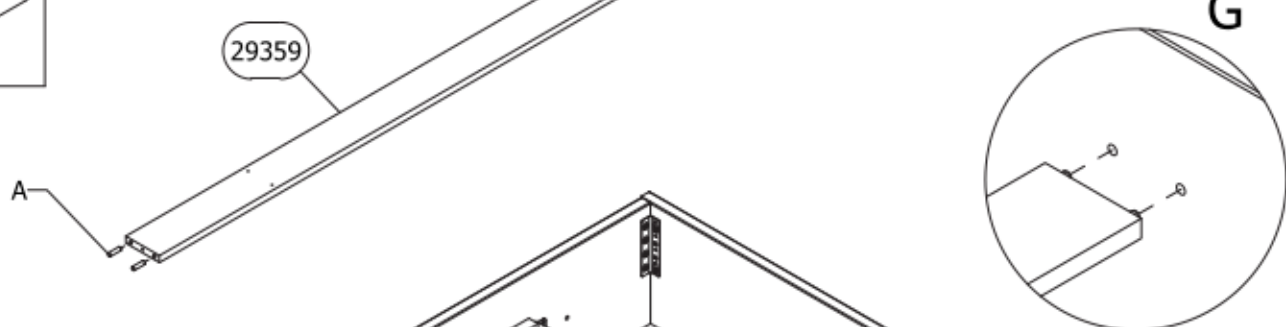

11

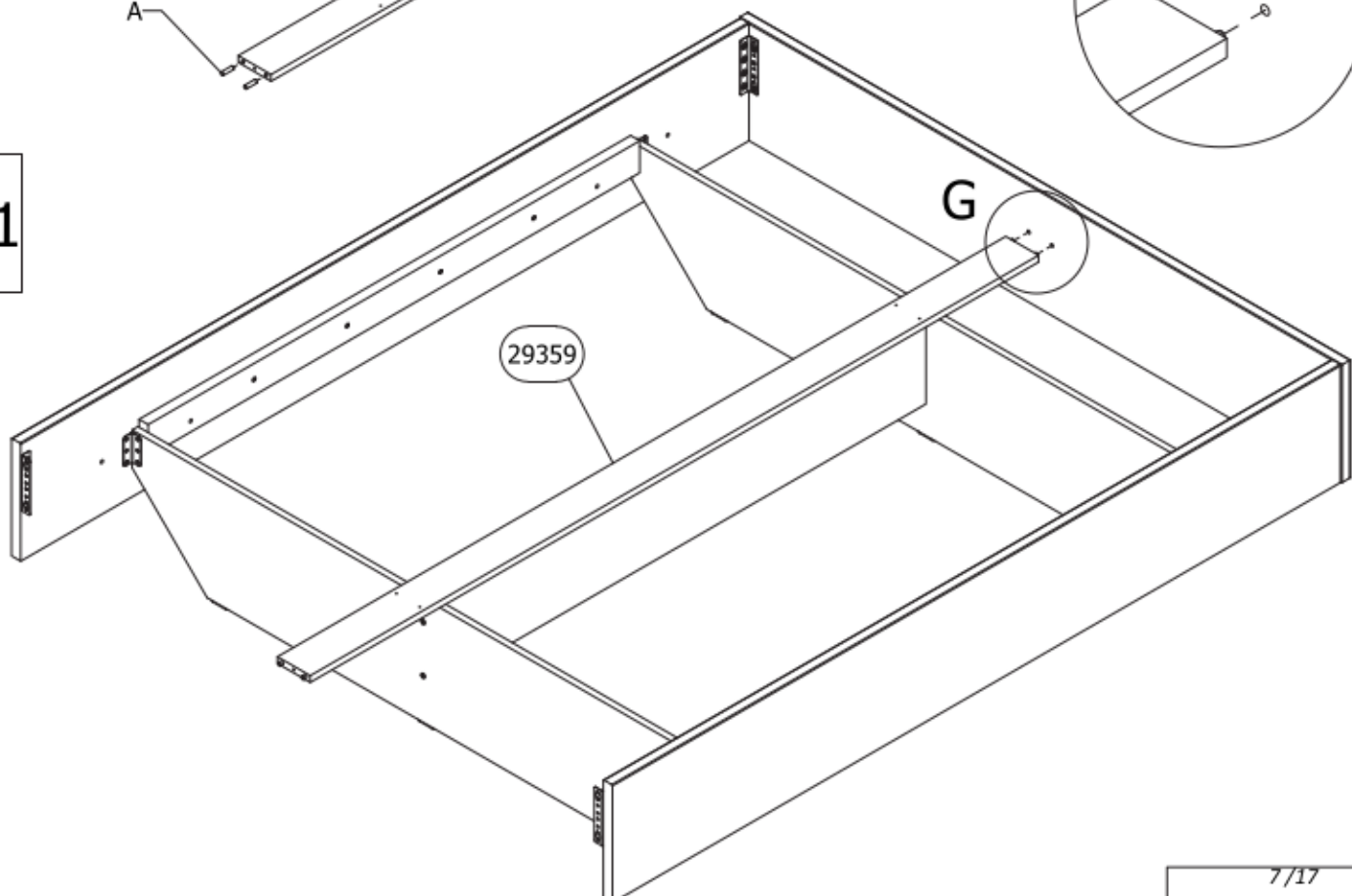

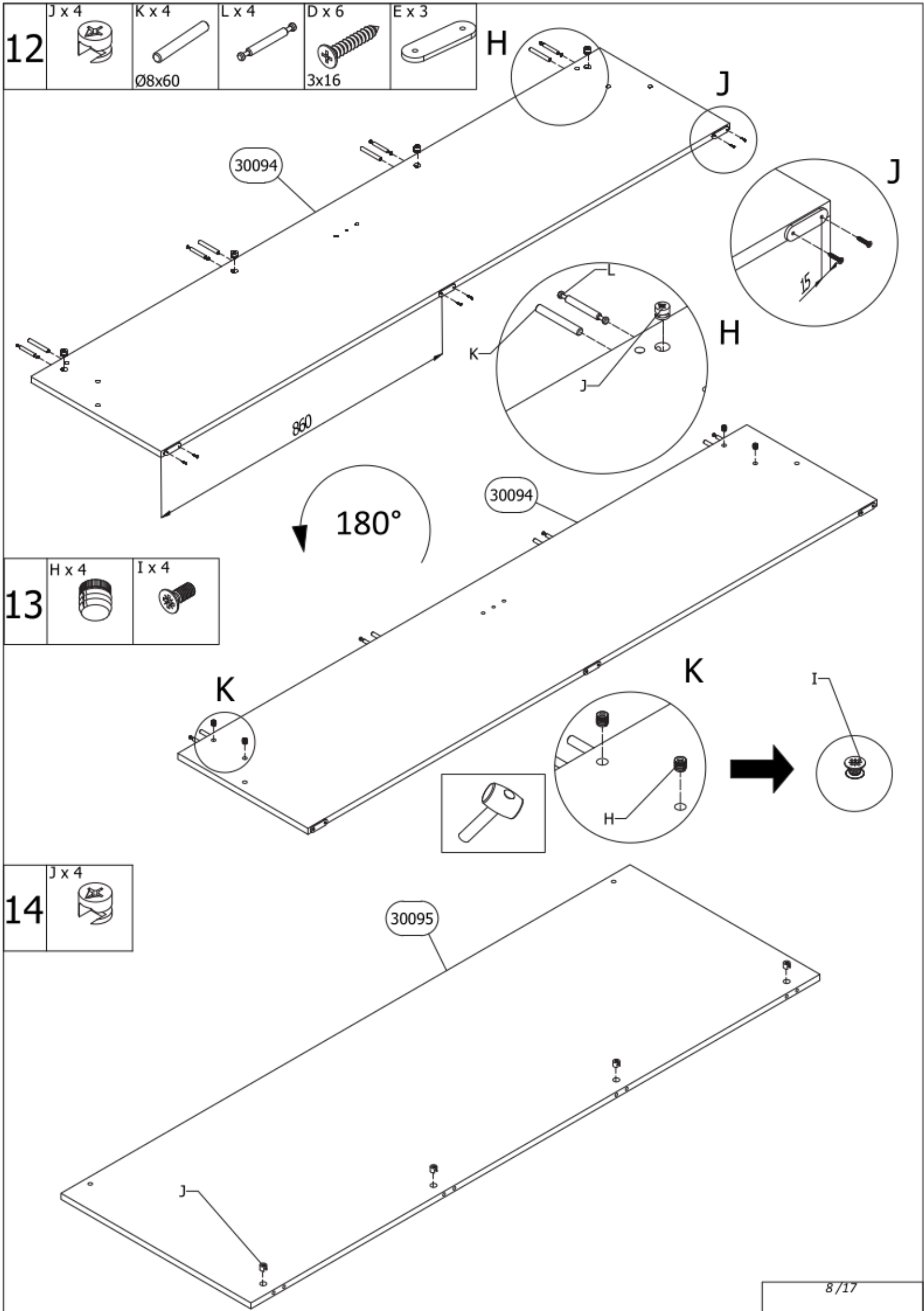

- |           |           |                    |           |                   |           |
|-----------|-----------|--------------------|-----------|-------------------|-----------|
| <b>12</b> | J x 4<br> | K x 4<br>Ø8x60<br> | L x 4<br> | D x 6<br>3x16<br> | E x 3<br> |
|-----------|-----------|--------------------|-----------|-------------------|-----------|

- |           |           |           |
|-----------|-----------|-----------|
| <b>13</b> | H x 4<br> | I x 4<br> |
|-----------|-----------|-----------|

- |           |           |
|-----------|-----------|
| <b>14</b> | J x 4<br> |
|-----------|-----------|



15

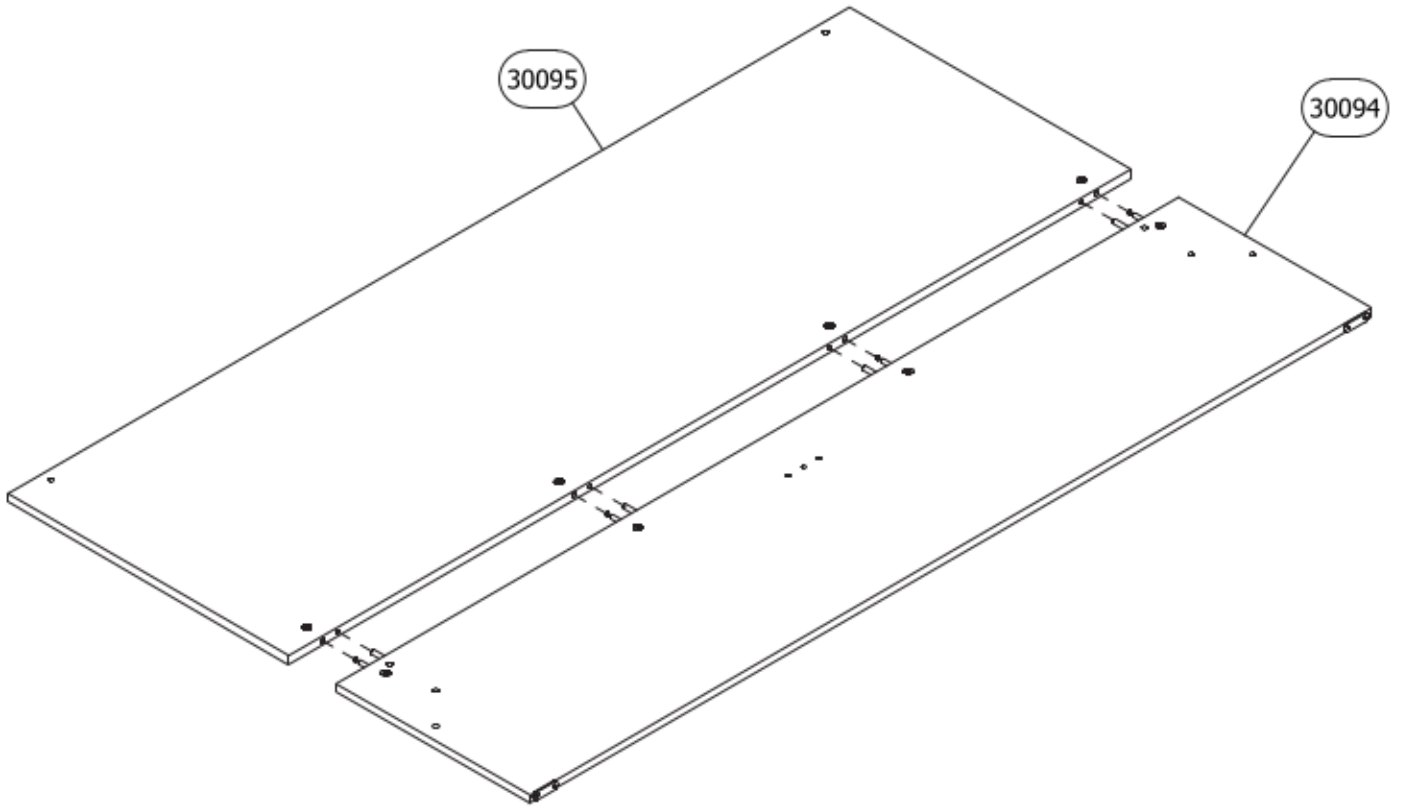

16

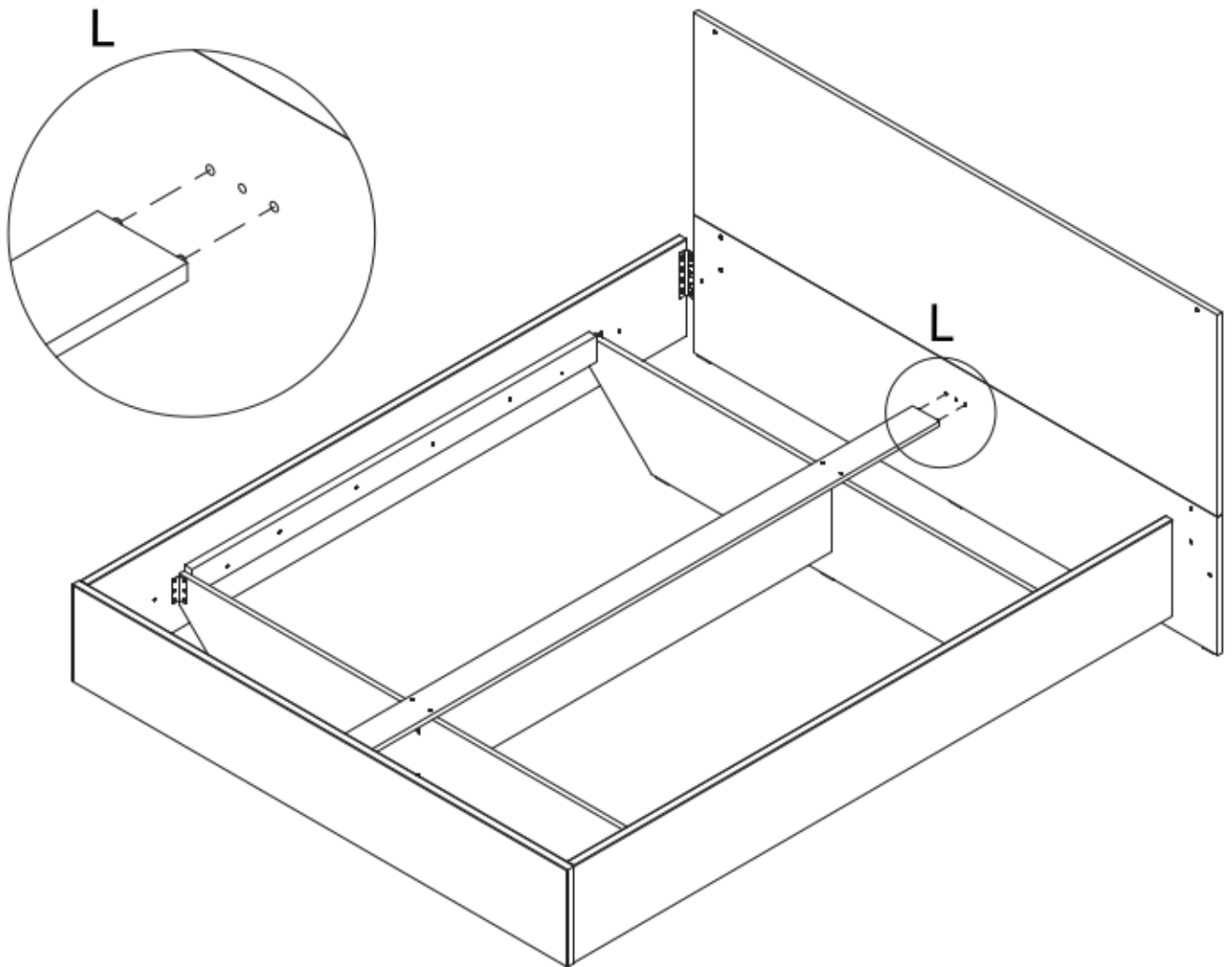

17

B x 4



4x16

M

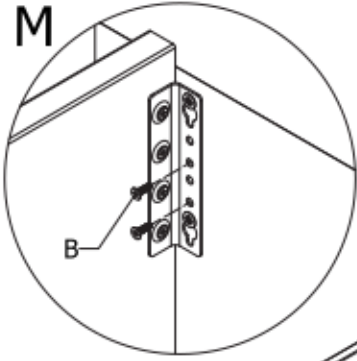

M

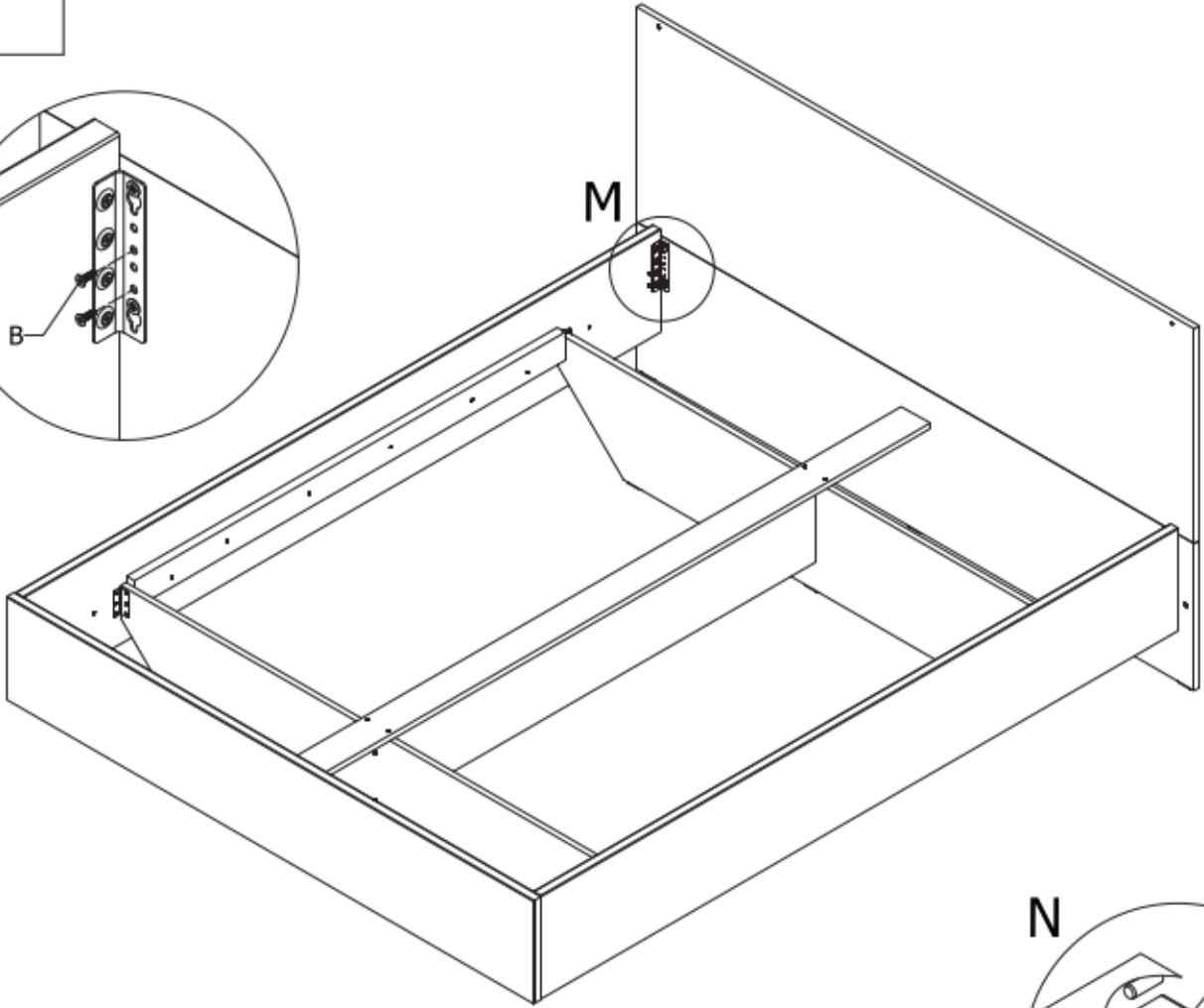

18

C x 1



Ø7x50

R x 3



B x 10



4x16

S x 1



N

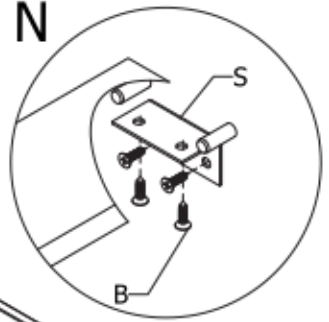

N

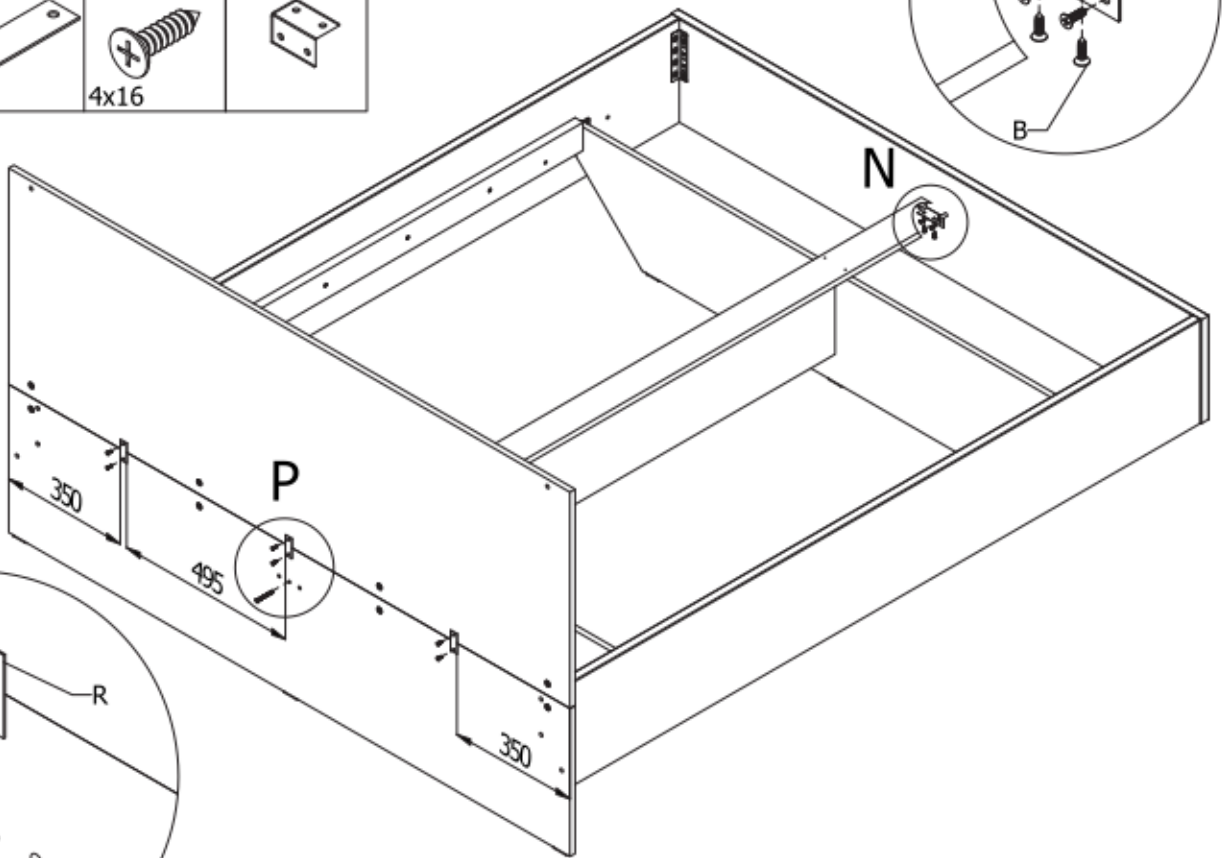

P

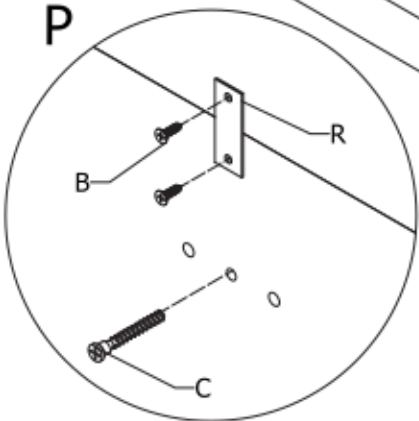

**19**

F x 4 4x30	S x 1	B x 4 4x16
---------------	-------	---------------

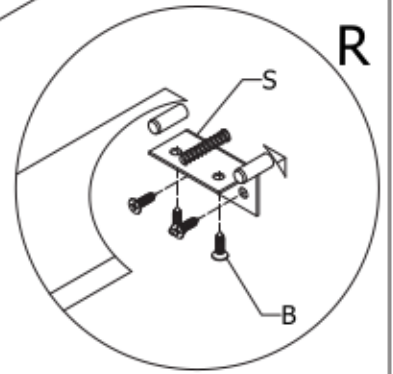
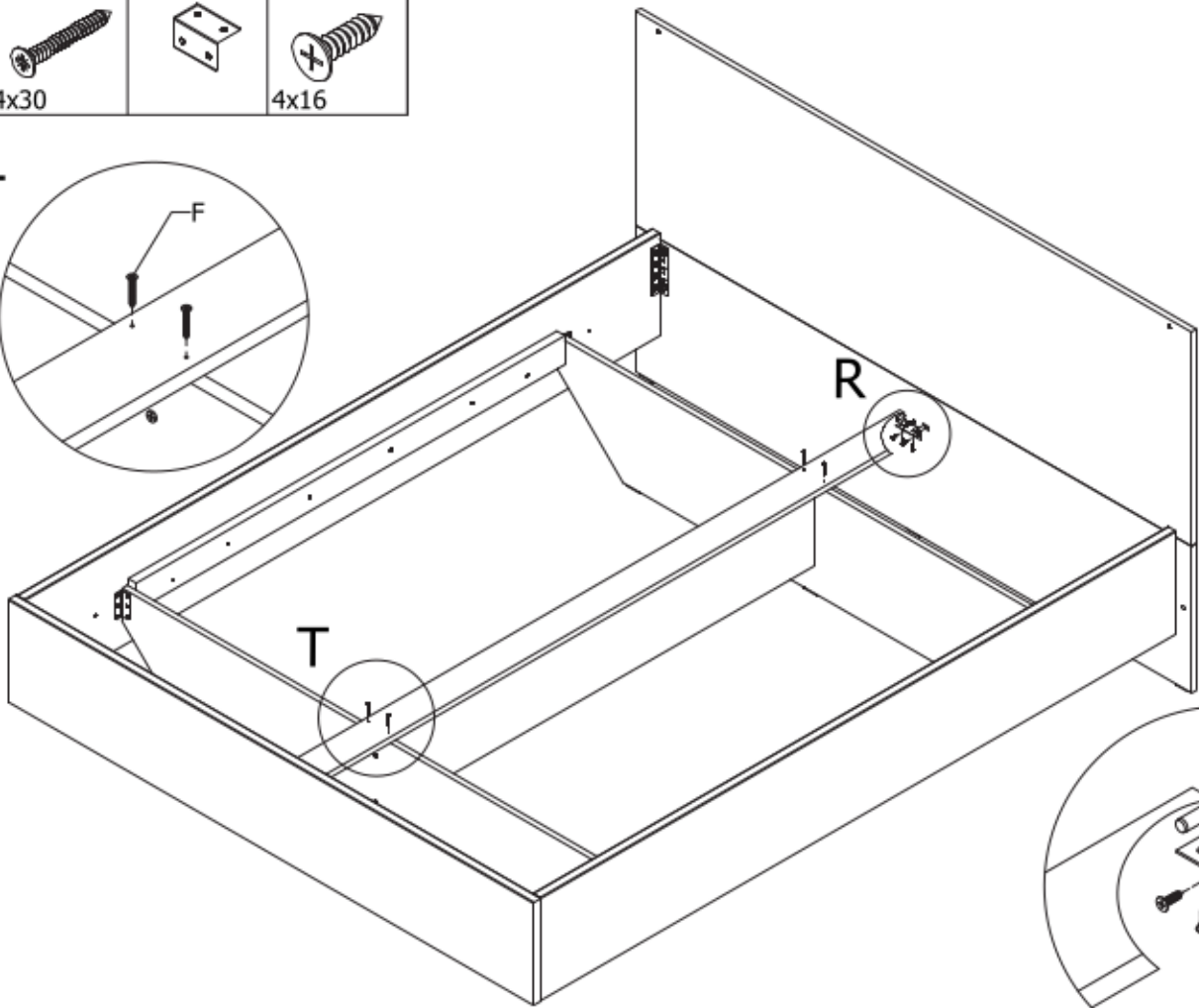
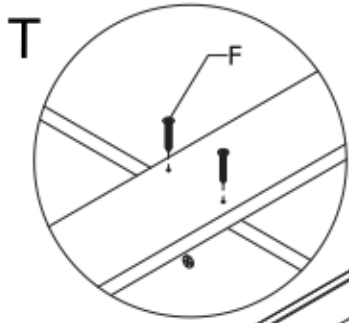

**20**

T x 2
-------

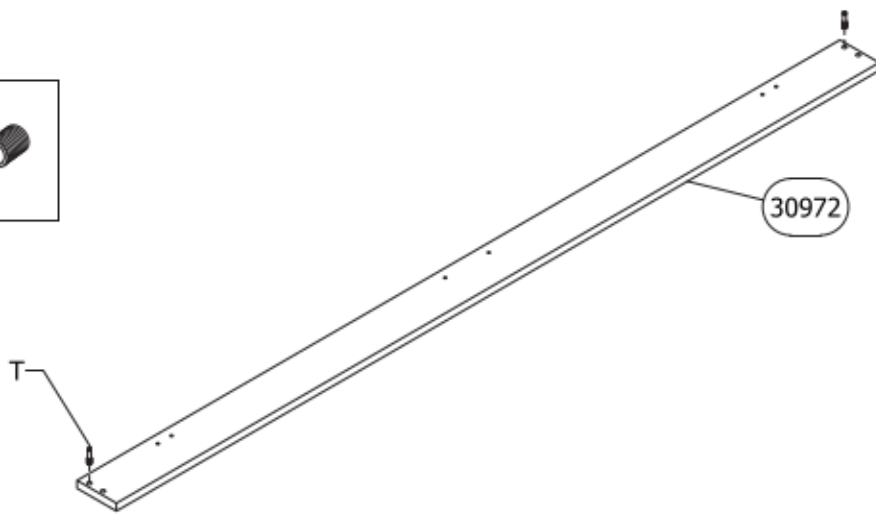

**21**

A x 1 Ø8x30	J x 1
----------------	-------

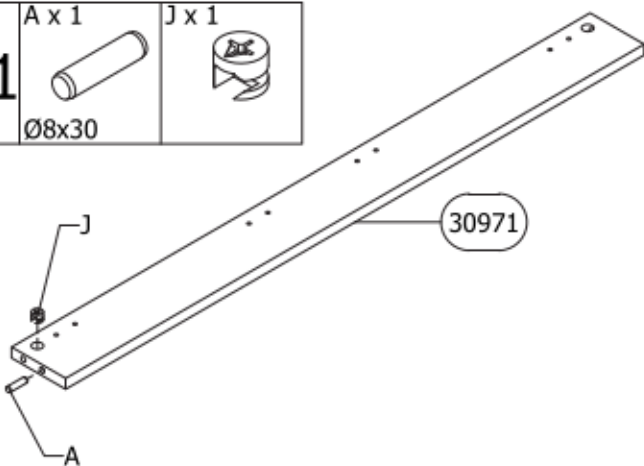

**22**

A x 1 Ø8x30	J x 1
----------------	-------

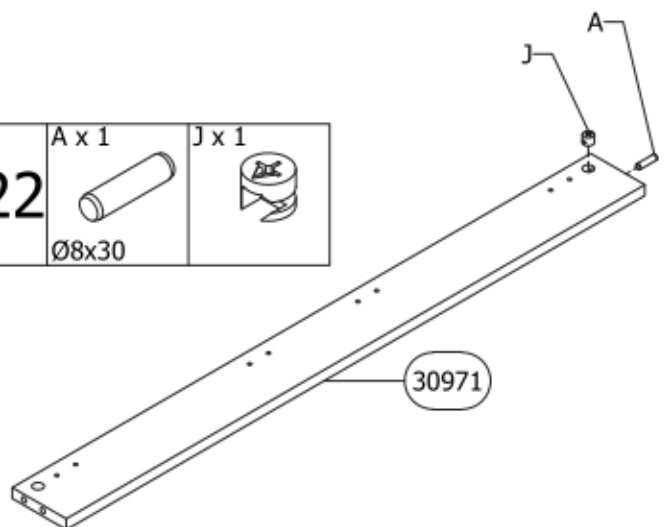

23

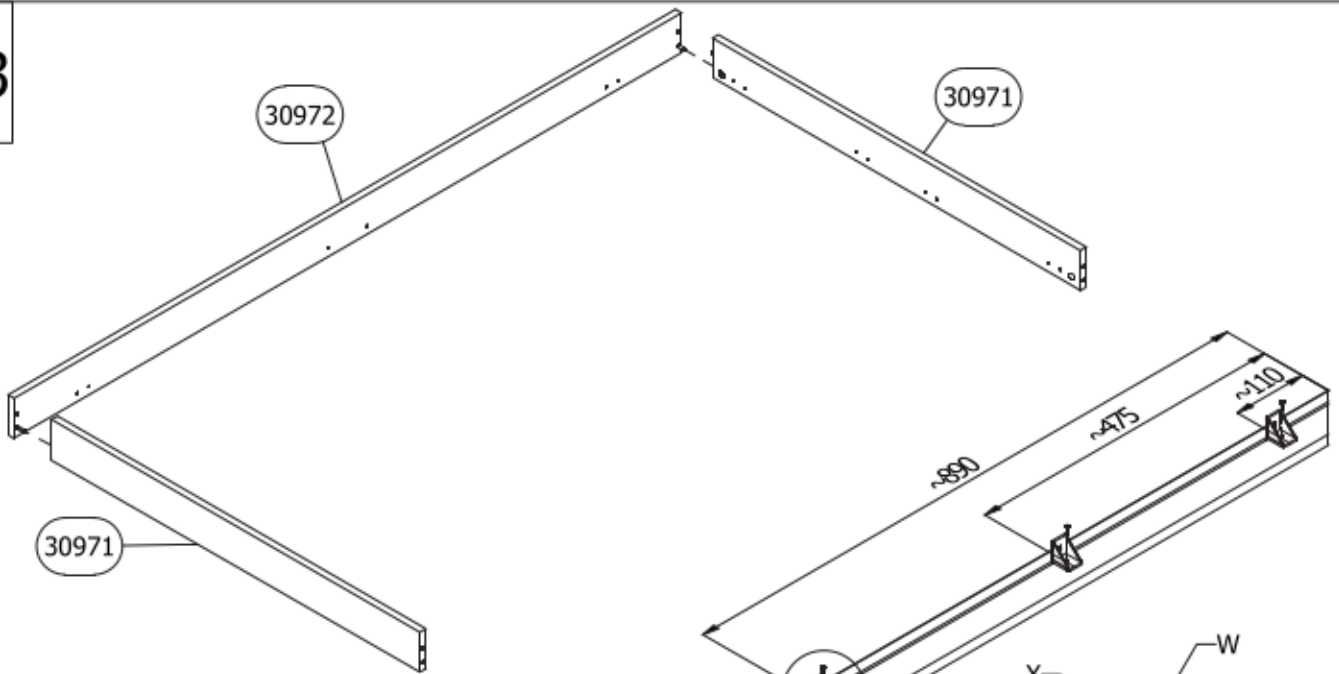

24

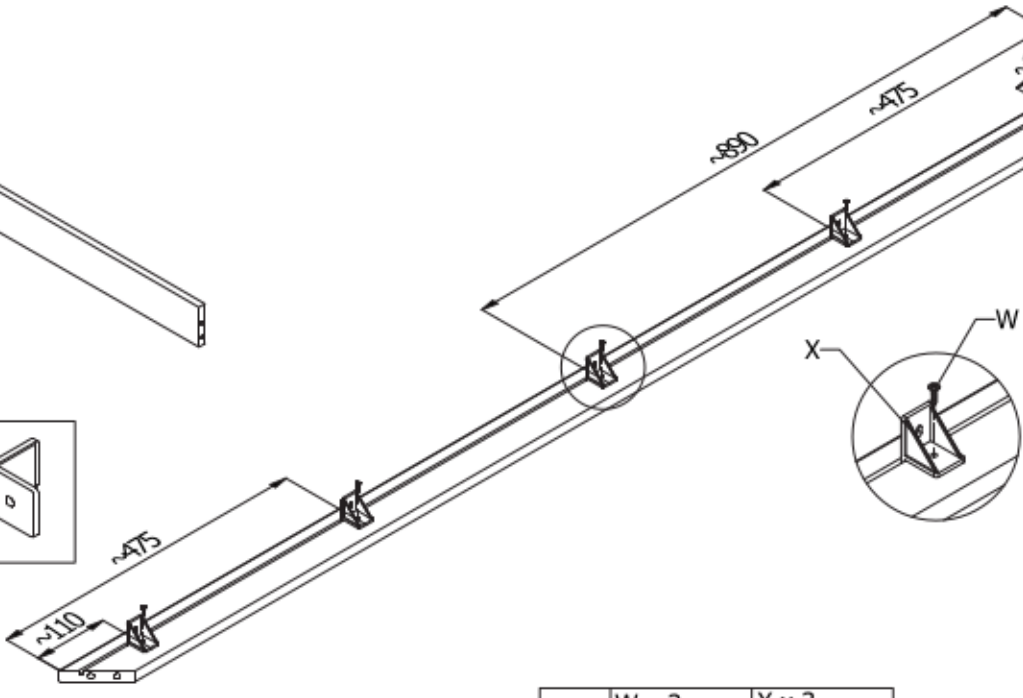
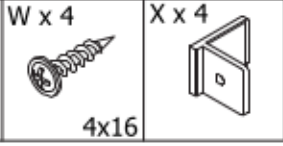

25

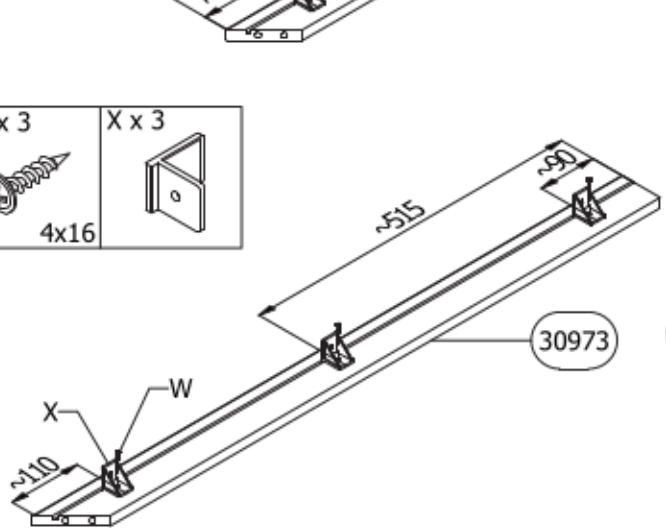
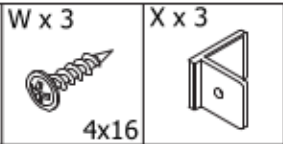

26

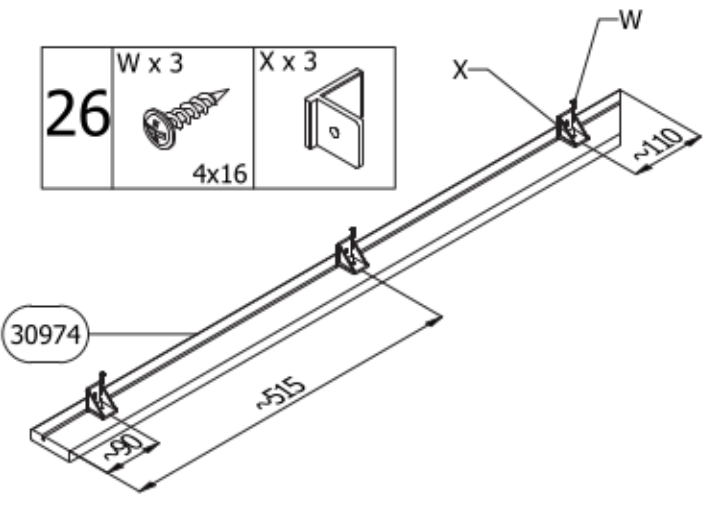
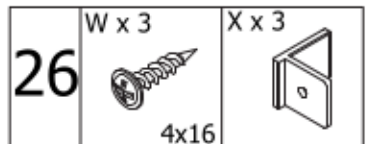

27

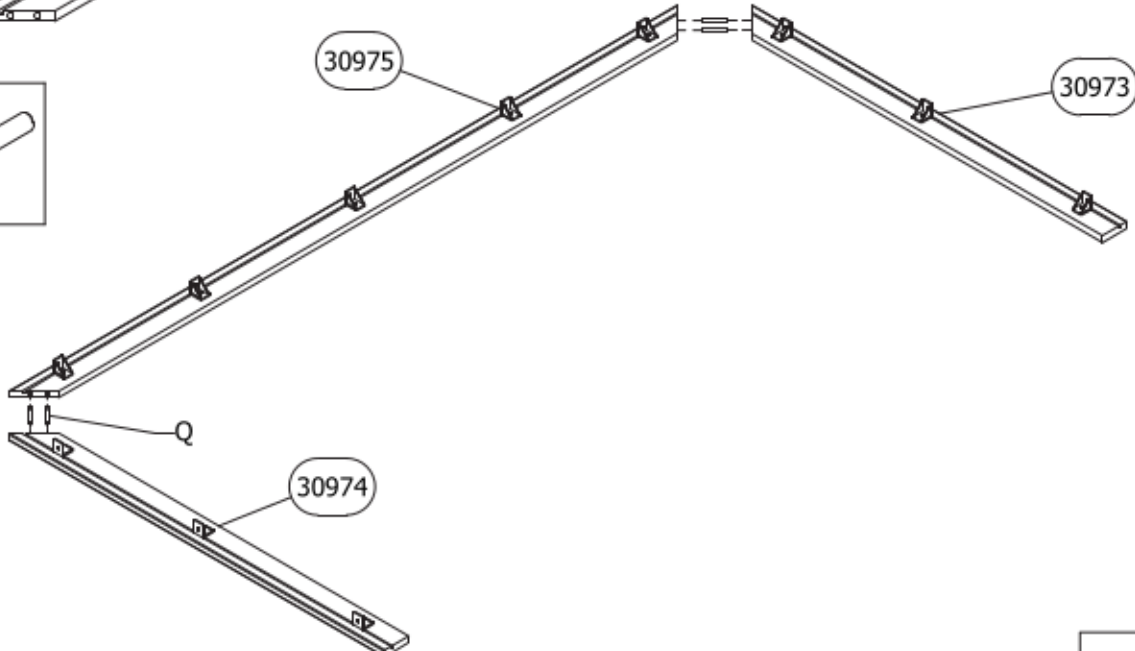
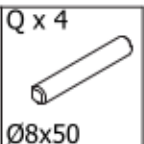



28

R x 2	B x 4	W x 11
	4x16	4x16

V1

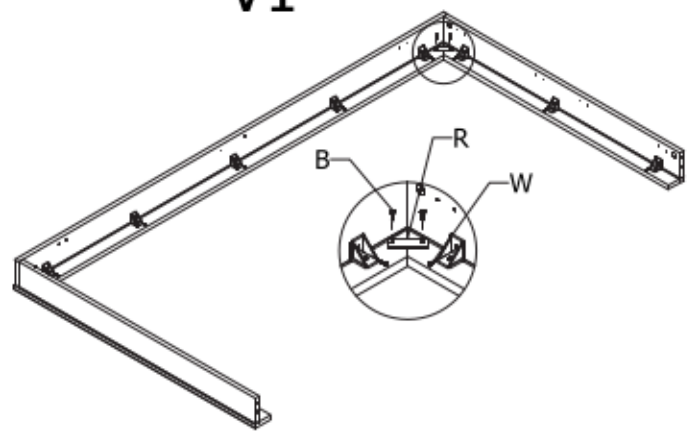

V2

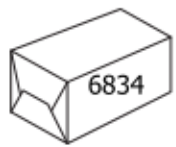

- 10x10 L=1650mm x1
- 10x10 L=550mm x2
- x6
- 3x16 - 6kom

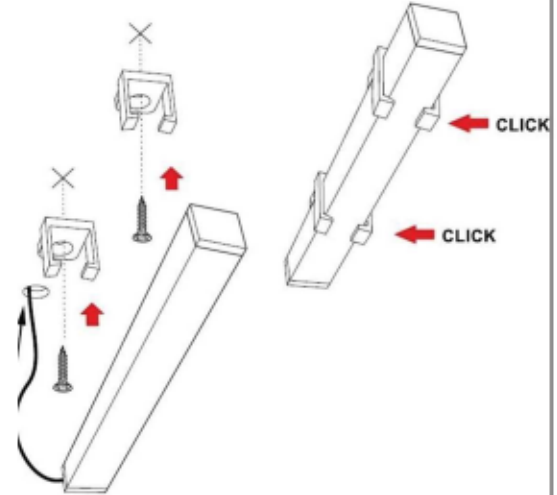
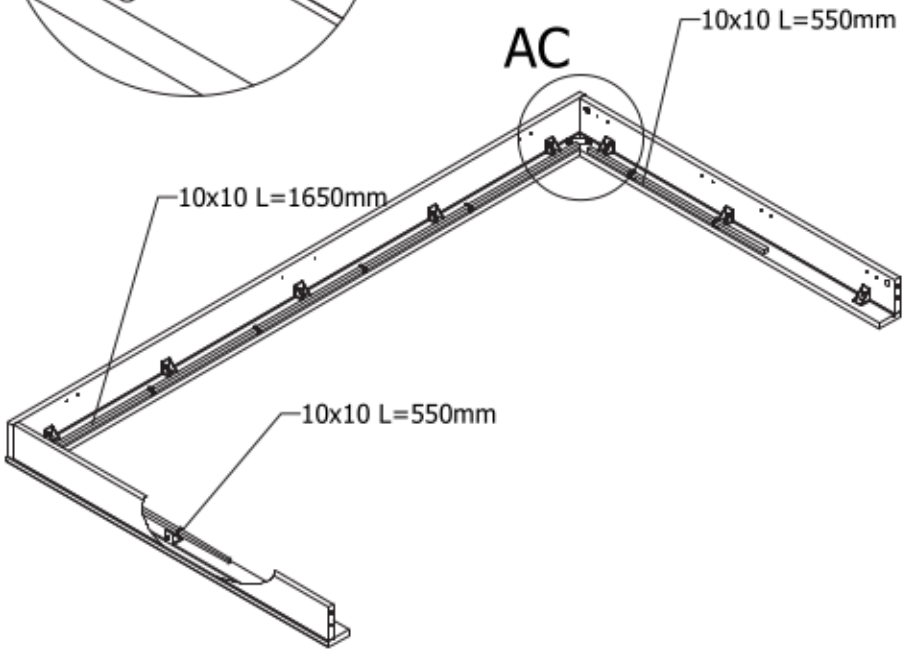
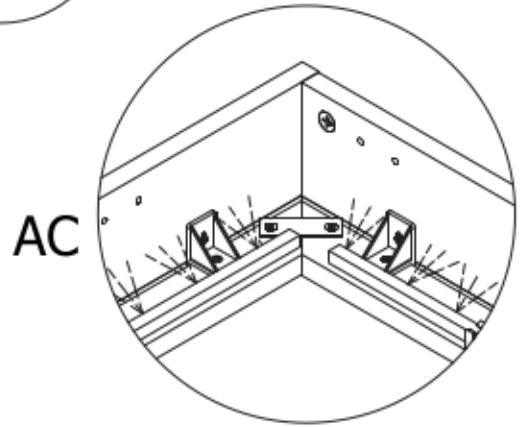
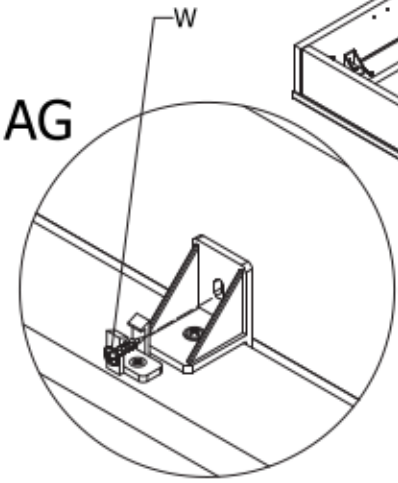
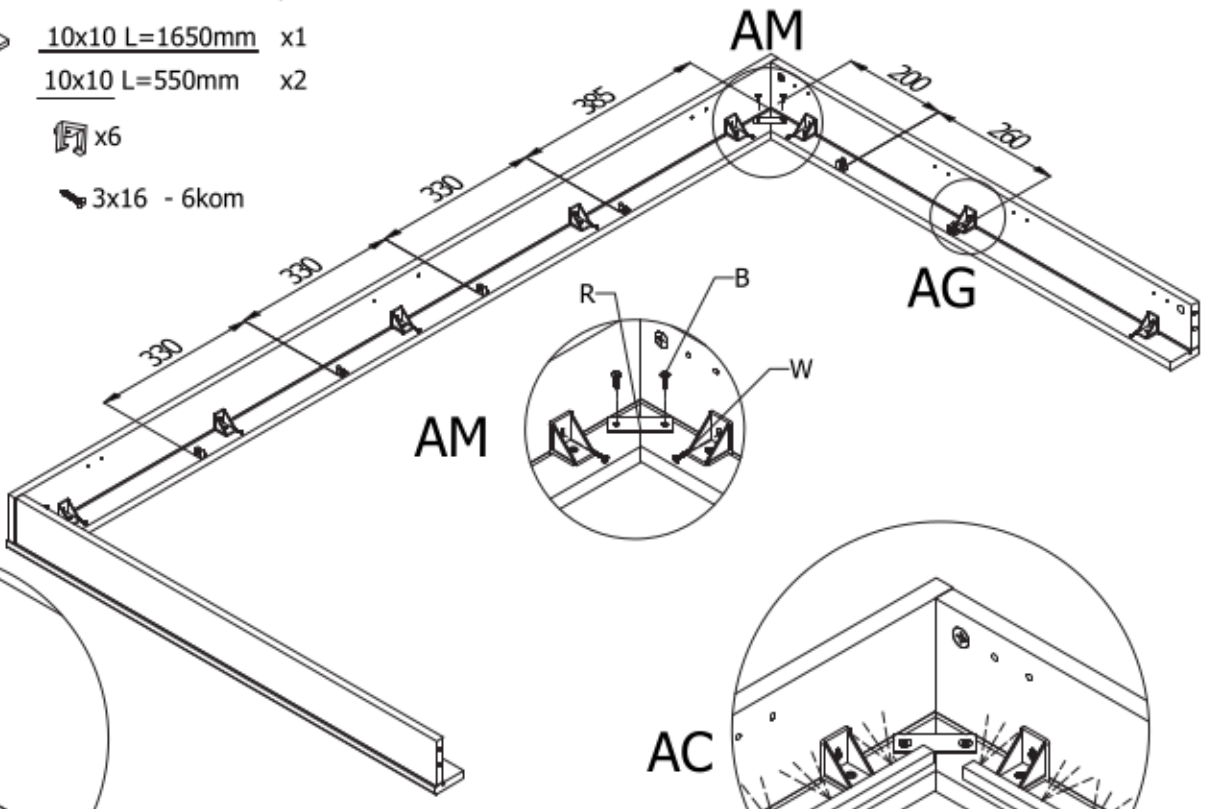

V1

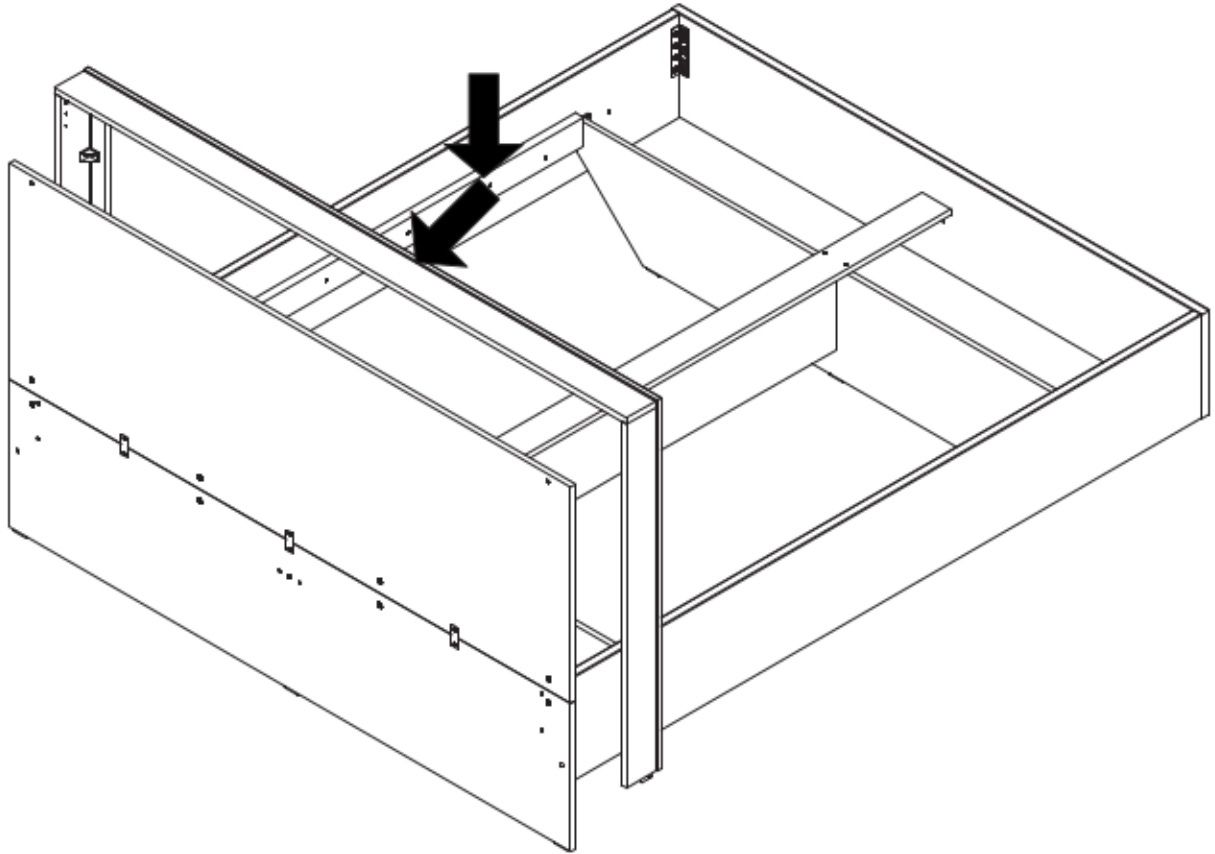

V2

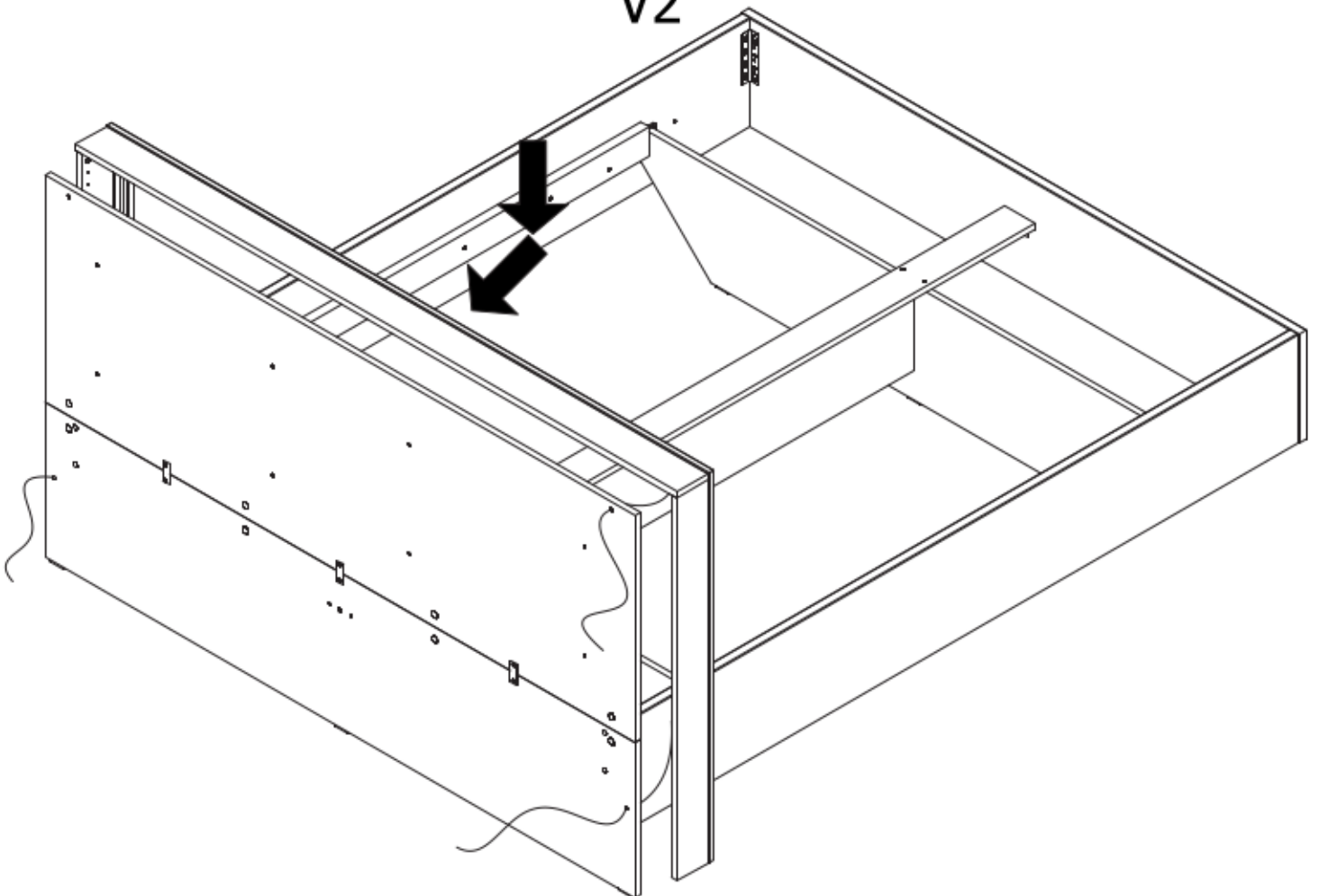

30

O x 9



B x 18



4x16

P x 18



Ø6.3x13

U x 8



V x 4

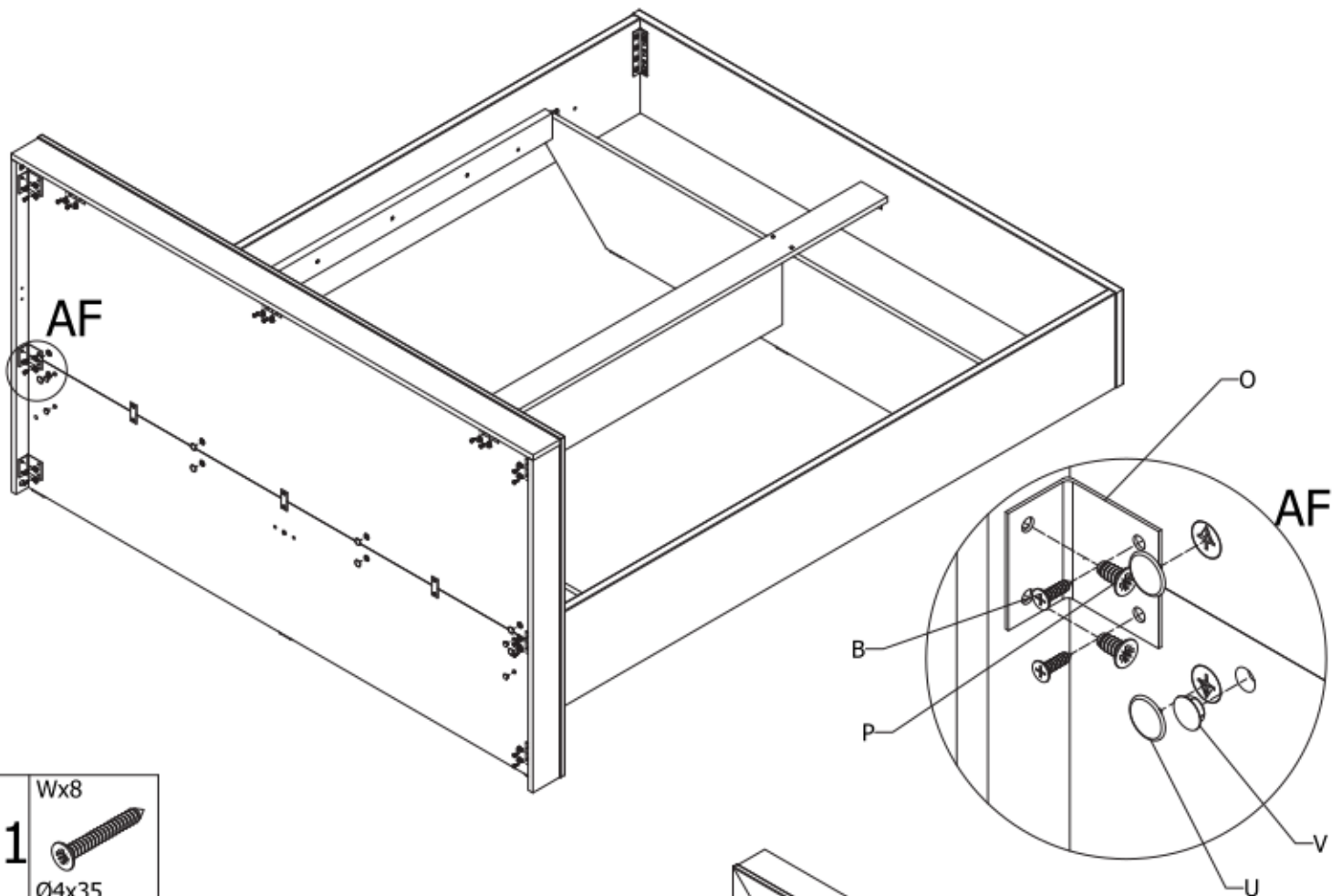

31

W x 8



Ø4x35

AE

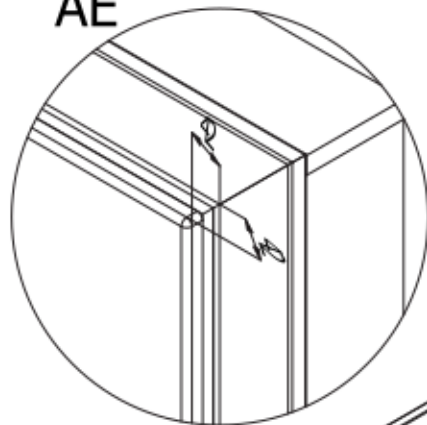

31013035

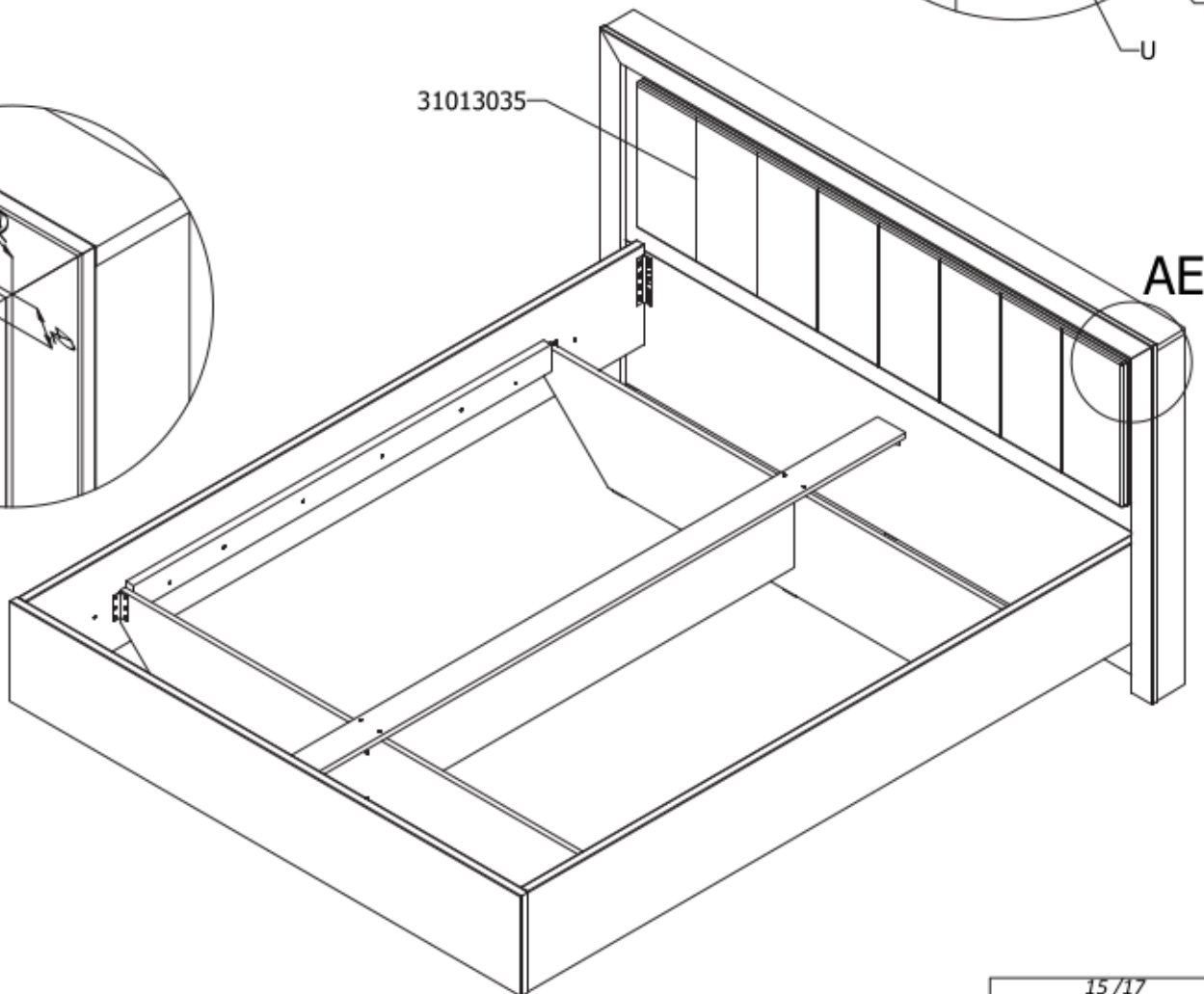

32

Y x 8

Z x 8



4x30

4x35

