

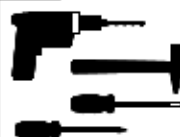

1



2



3



- | | |
|--|------------------------------------|
| [DE] Montageanleitung | [PL] Instrukcja montażu |
| [GB] Assembly instruction | [CZ] Montážní návod |
| [FR] Notice de montage | [SK] Montážny návod |
| [ES] instrucciones de montaje | [HR] Upute za montažu |
| [IT] Istruzioni di montaggio | [MT] Istruzzjonijiet |
| [PT] Instruções de montagem | [SI] Navodila za montažo |
| [NL] Montage-instructies | [HU] Szerelési útmutató |
| [DK] Monteringsvejledning | [RO] Instrucțiuni de montaj |
| [SE] Monteringsanvisningar | [BG] ИНСТРУКЦИИ ЗА МОНТАЖ |
| [FI] Aasennusohjeet | [CN] 彙編指令 |
| [IS] Leiðbeiningar um samsetningu | [GR] οδηγίες συναρμολόγησης |
| [EE] Paigaldusjuhendid | [ME] Uputstvo za montažu |
| [LT] Surinkimo instrukcijos | [MK] сборанието инструкции |
| [LV] Montažas instrukciju | [RU] инструкции по сборке |
| [TR] Montaj talimatları | [RS] uputstva za montazu |

CZ Bezpečnostní pokyny

- Důležité informace
- Čtěte prosím pečlivě a pozorně
- Tyto informace si uchovejte



DŮLEŽITÉ. Montáž nábytku musí být provedena podle montážního návodu, a to kvalifikovanou osobou. Veškeré elektrické a sanitární instalace smí provádět pouze autorizovaný, odborně způsobilý personál.

Aby se zamezilo převrácení nábytku, musí být pevně ukotven ke stěně. Chybná montáž, příp. neprovedené upevnění ke stěně může vést k funkčnímu znehodnocení, poškození a/nebo k těžkým poraněním.

Vzhledem k velké rozmanitosti zdí a materiálů stěn jsme nepřiložili žádné montážní prvky pro upevnění. Informujte se prosím u odborného prodejce o vhodném materiálu na upevnění podle Vašich stavebních podmínek. Za upevnění na zeď a za použité materiály nesete odpovědnost Vy sami.

Dodržujte maximální údaje o hmotnosti uvedené v montážním návodu. Sáček s kováním, díly kování a obalový materiál musí být uschovány mimo dosah kojenců a dětí, protože obsahují drobné díly a při spolknutí hrozí nebezpečí udušení.

Nebude-li respektován návod na obsluhu, provoz či montáž nebo budou-li vyměněny stavební díly, či provedeny změny na produktech nebo spotřebních materiálech, které neodpovídají originálním dílům, potom odpadají jakékoli nároky na záruku či odpovědnost za vady. GERMANIA nenesе žádnou odpovědnost za zranění osob či poškození majetku v důsledku nesprávné montáže, příp. neprovedeného upevnění ke stěně. Při přetížení, způsobeném lidmi, hrajícími si dětmi nebo jinými vlivy, nepřebíráme jako výrobce rovněž žádnou odpovědnost.

SK Bezpečnostné pokyny

- Dôležitá informácia
- Návod si dôkladne a pozorne prečítajte
- Túto informáciu uschovajte



DOLEŽITÉ. Montáž nábytku musí robiť odborník presne podľa návodu na montáž. Všetky sanitné a elektroinštalácie smie vykonávať len autorizovaný odborný personál.









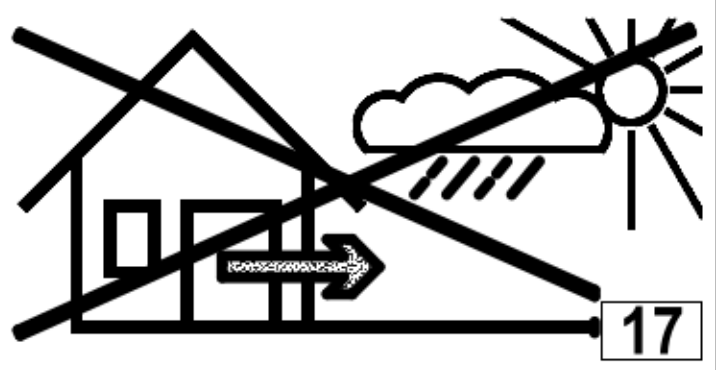
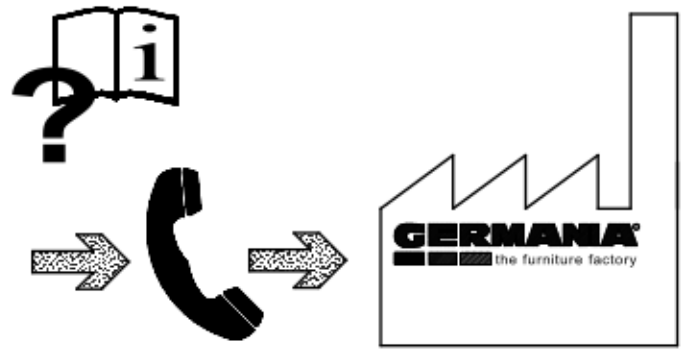
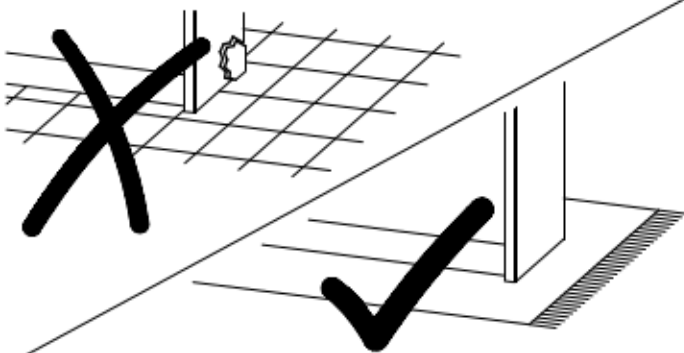
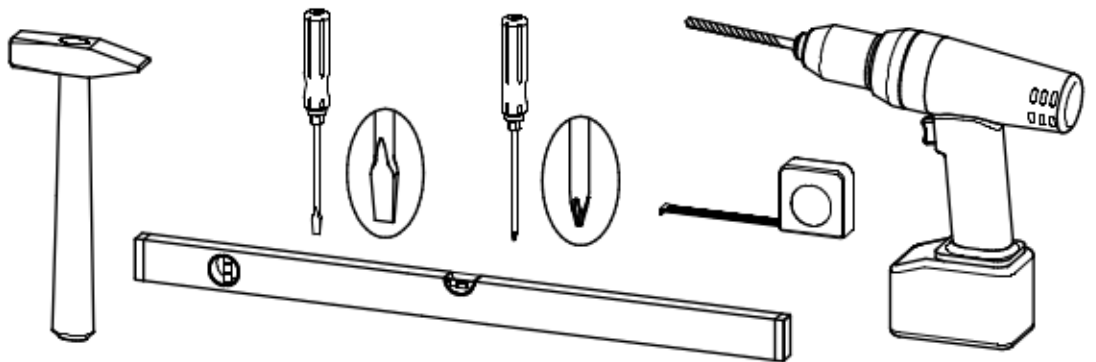
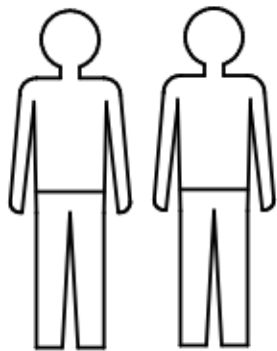
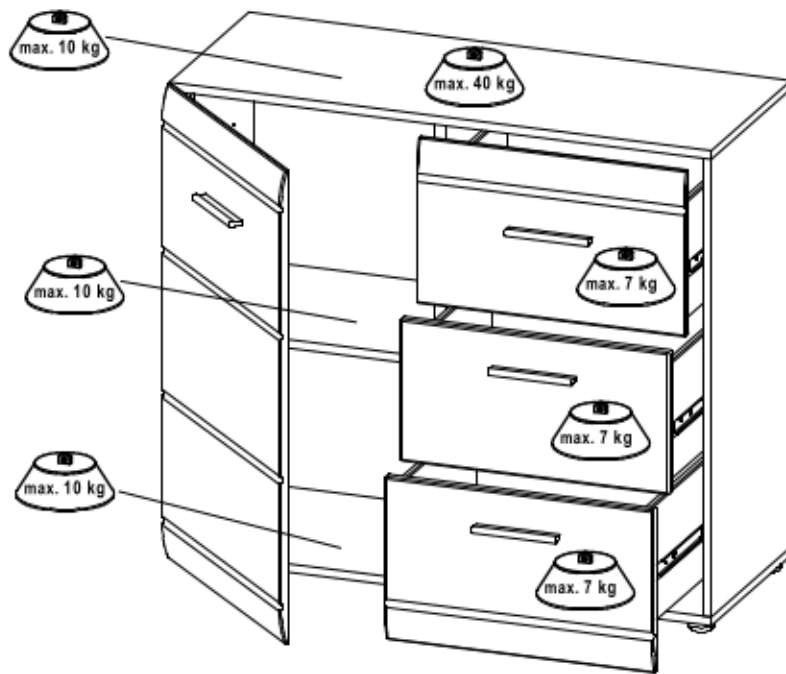





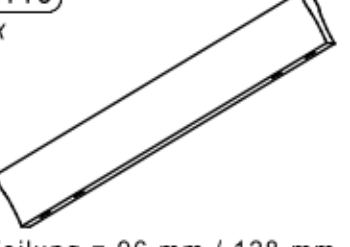









Aby sa zabránilo prevráteniu nábytku, musí byť tento pevne ukotvený na stene. Nesprávna montáž príp. chýbajúce upevnenie na stene môže viesť k poruchám funkčnosti, poškodeniu a/alebo k ťažkým zraneniam.

Kvôli veľkej rozmanitosti druhov stien a materiálov sme nepriložili upevňovací materiál. Ohľadom vhodného upevňovacieho materiálu podľa Vašej stavebnej situácie sa informujte prosím v špecializovaných obchodoch. Vy sám ste zodpovedný za upevnenie na stene a za použité materiály.

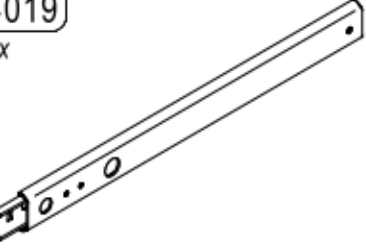
Dodržiaavajte hodnoty maximálnej hmotnosti uvedené v návode na montáž. Vrečko s kovaním, časti kovania a baliaci materiál uschovávajúte mimo dosahu dočiat a detí, pretože obsahujú malé diely, ktoré sa dajú prehltnúť a hrozí nebezpečenstvo udusenía.

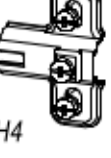
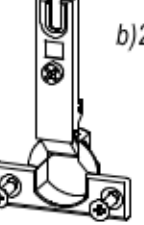
Ak nedodržíte návod na obsluhu, prevádzku a montáž, ak vymeníte stavebné diely, vykonáte zmeny na produktoch alebo použijete spotrebné materiály, ktoré nezodpovedajú originálnym dielom, zanikajú akékoľvek nároky na poskytnutie záruky. Spoločnosť GERMANIA neručí za zranenia osôb a vecné škody, ktoré vzniknú následkom nesprávnej montáže príp. chýbajúceho upevnenia na stene. Za preťaženia, ktoré spôsobia ľudia, hrajúce sa deti alebo iné vplyvy, nepreberáme ako výrobca žiadnu zodpovednosť.



<p>2218 12 x</p>  <p>Ø8 x 30mm</p>	<p>1116 12 x</p>  <p>Ø15mm</p>	<p>1114 12 x</p> 	<p>1162 4 x</p> 	<p>5419 4 x</p>  <p>Teilung = 96 mm / 128 mm</p>	
<p>1046 8 x</p>  <p>Ø4 x 30 mm</p>	<p>4014 5 x</p>  <p>Ø45 mm</p>	<p>1165 5 x</p>  <p>Ø4x22mm</p>	<p>4095 4 x</p>  <p>10x10x13mm</p>	<p>1058 4 x</p>  <p>Ø3x15mm</p>	<p>1187 1 x</p>  <p>90x30x15</p>
<p>1298 2 x</p>  <p>Ø4x15mm</p>	<p>1267 8 x</p>  <p>Ø3x16</p>	<p>1104 8 x</p>  <p>Ø15x1,2mm</p>	<p>811 322 12 x</p>  <p>Ø20x6,4x3 mm</p>	<p>1458 6 x</p>  <p>Ø6,3x16</p>	<p>1236 6 x</p>  <p>Ø6,3x11</p>
<p>1156 4 x</p> 	<p>4019 6 x</p>  <p>27x278 mm</p>	<p>1235 6 x</p>  <p>M4x8</p>	<p>4834 1 x</p>  <p>a)2x H4</p>  <p>b)2x</p>		
<p>1155 4 x</p> 	<p>1192 2 x</p>  <p>Ø5mm</p>	<p>4271 2 x</p> 			

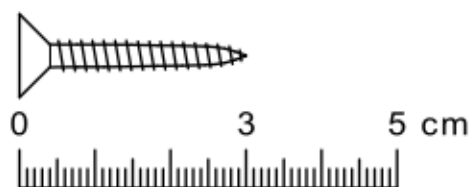

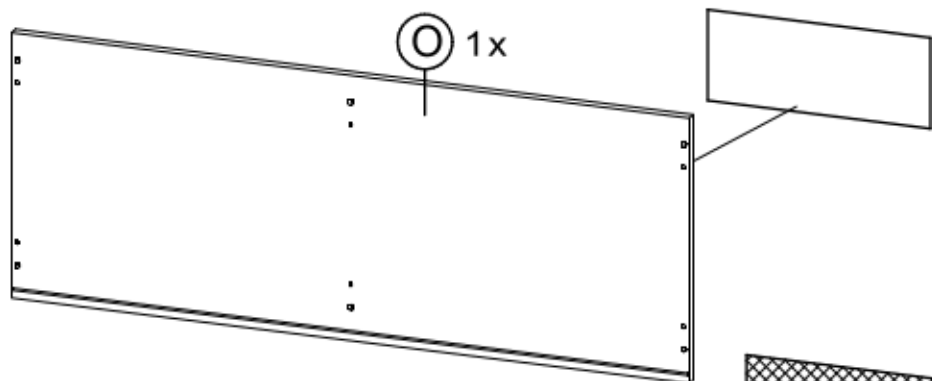

⓪ 1x

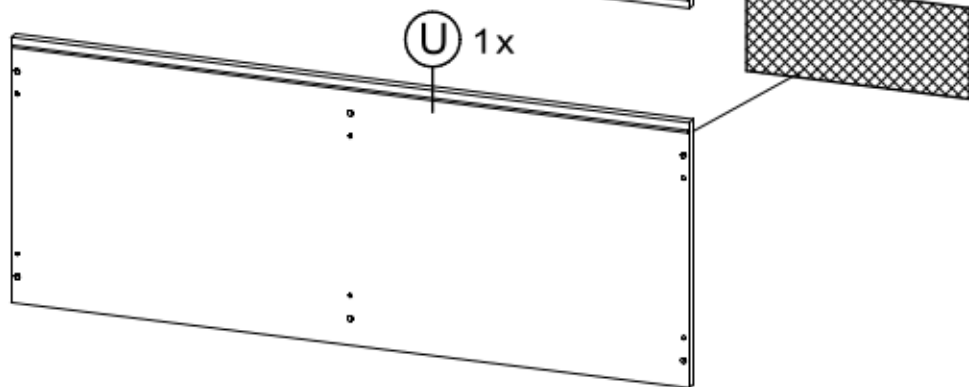

Ⓤ 1x

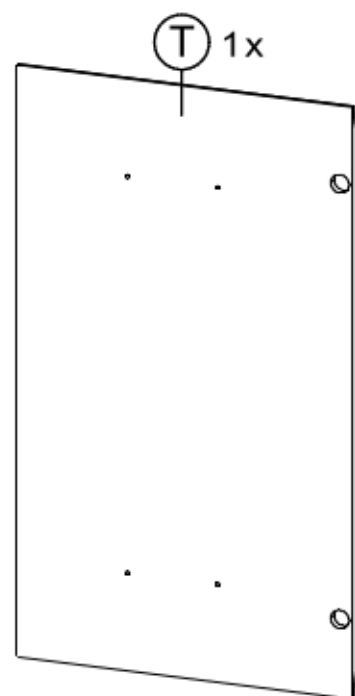

Ⓣ 1x

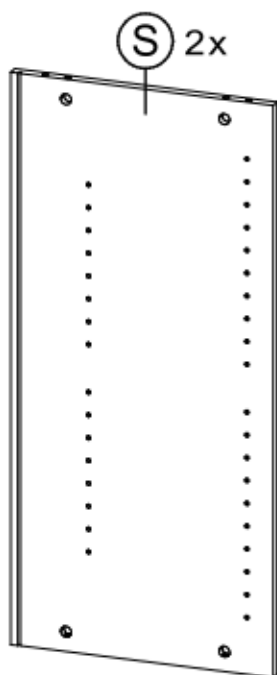

Ⓢ 2x

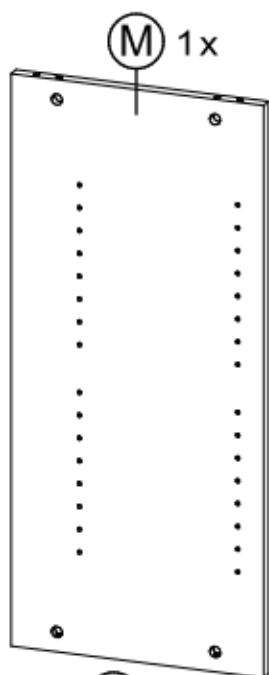

Ⓜ 1x

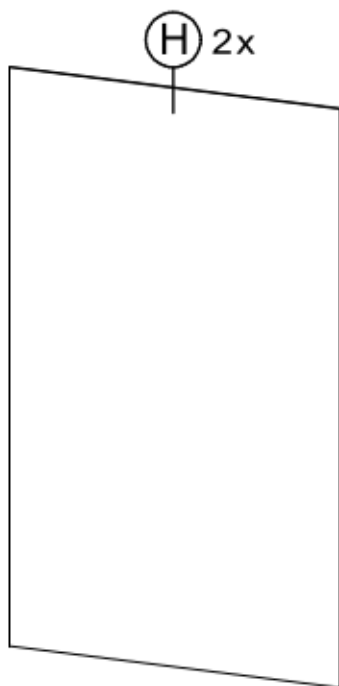

ⓗ 2x

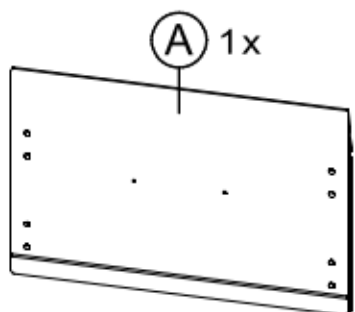

Ⓐ 1x

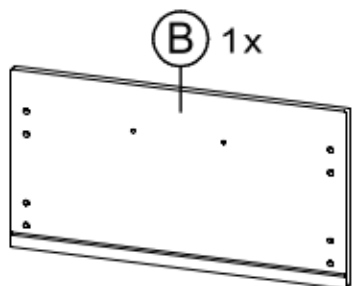

Ⓑ 1x

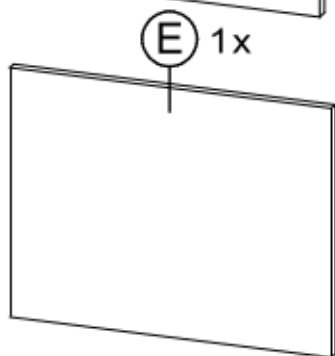

Ⓔ 1x

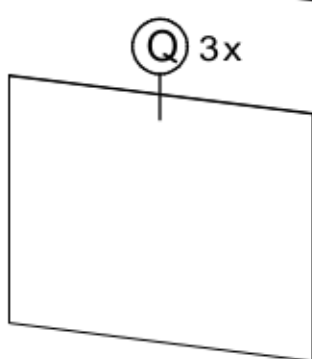

Ⓚ 3x

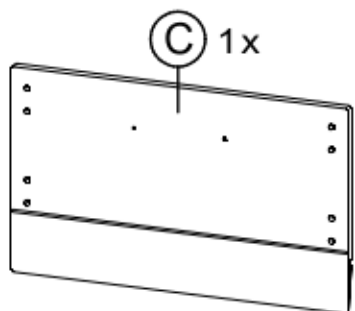

Ⓒ 1x

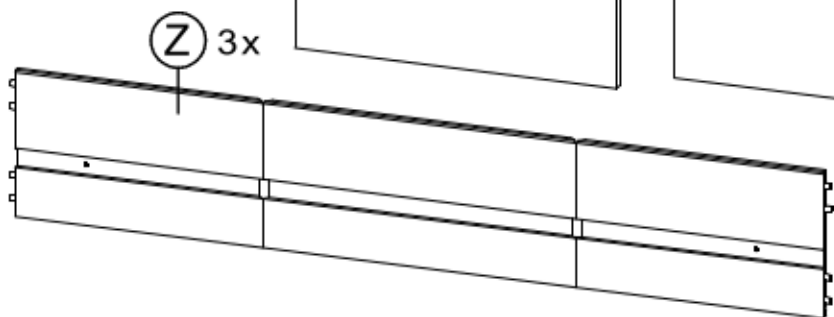

Ⓩ 3x

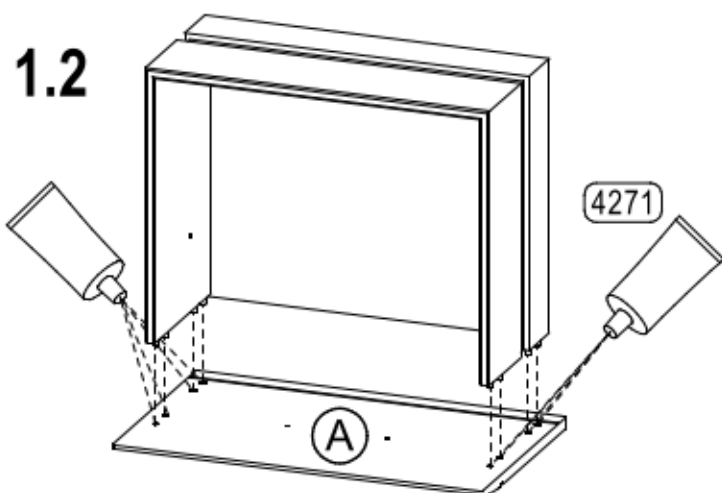
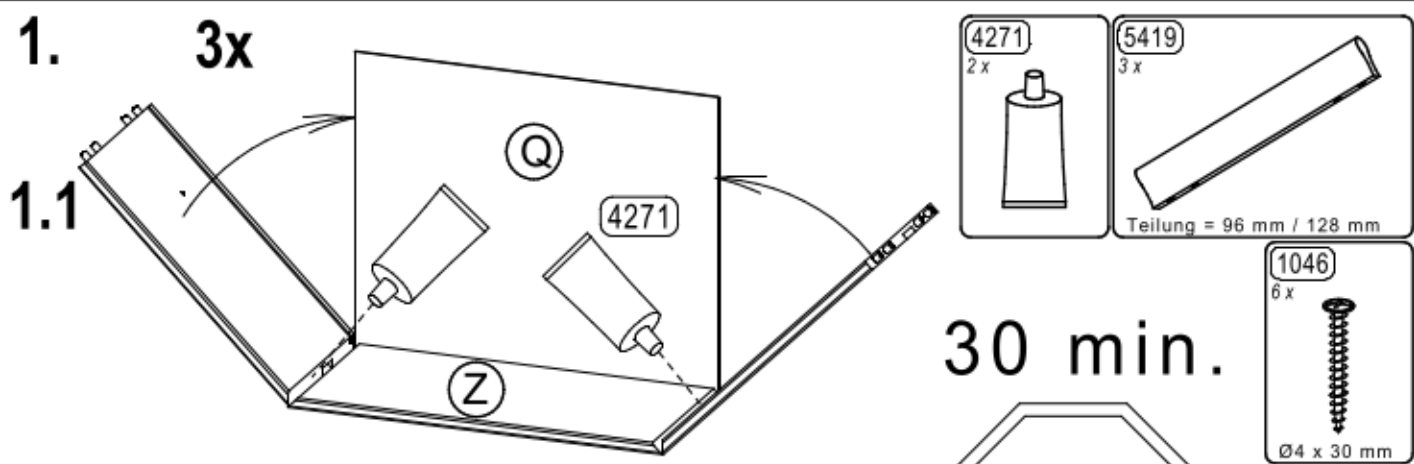

1.3

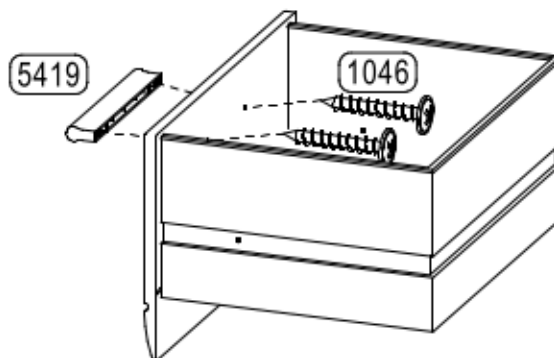
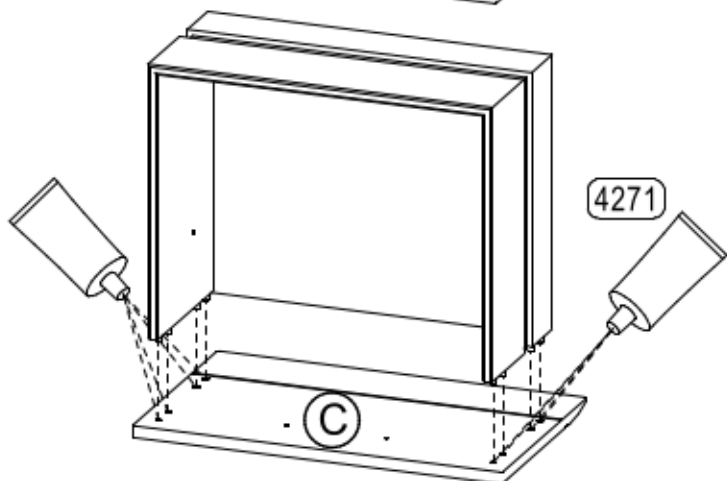
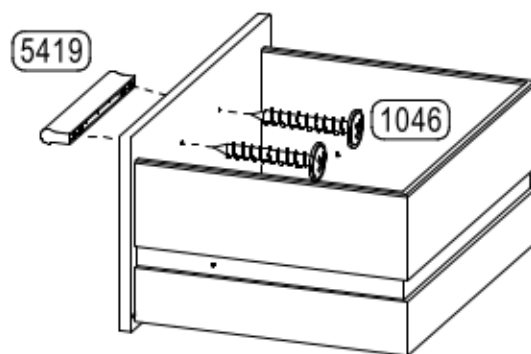
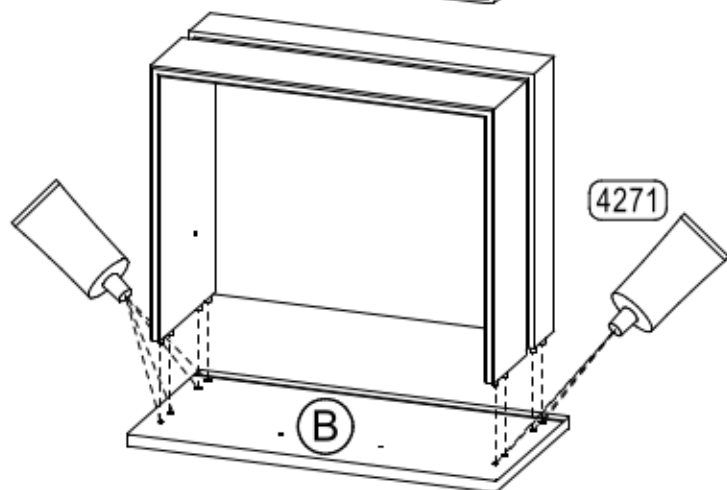
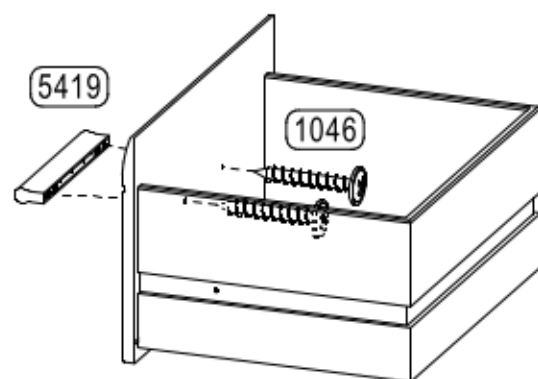

2.

2.1

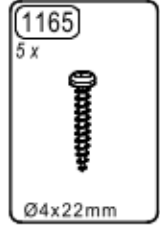
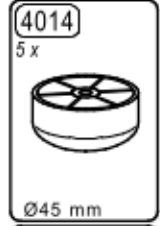
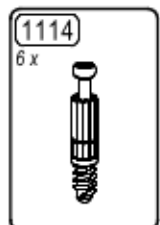
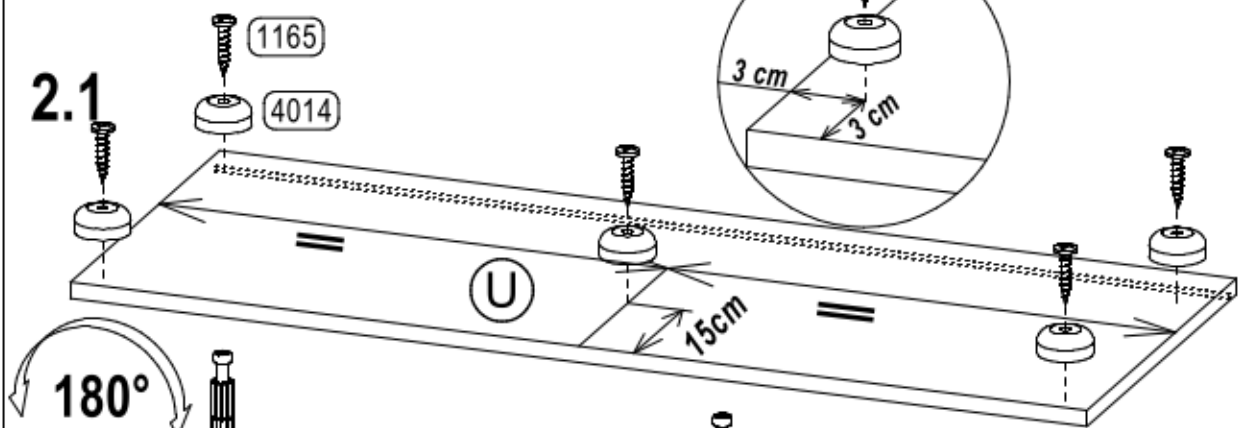

2.2

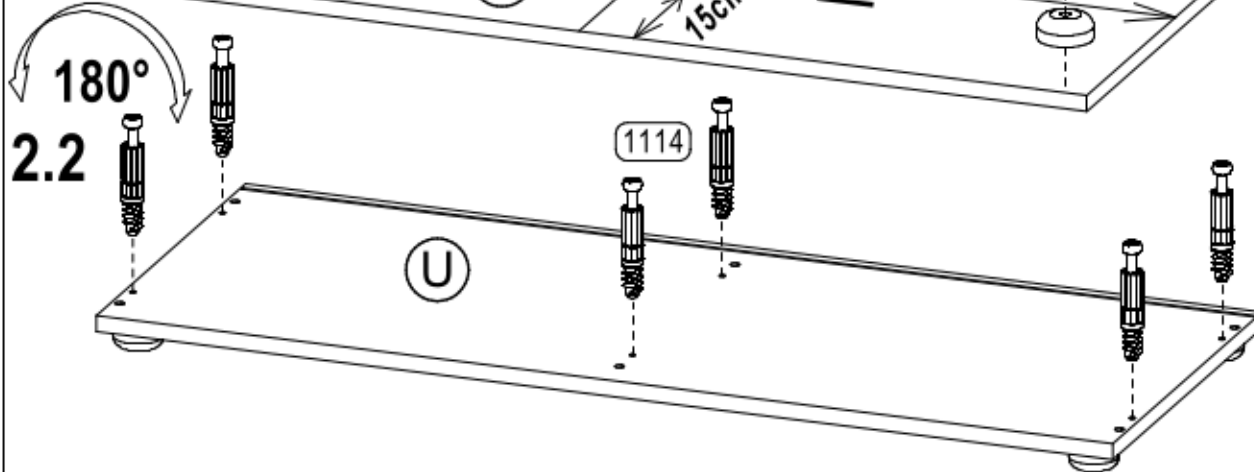

3.

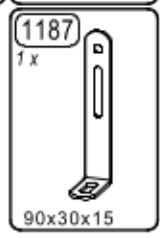
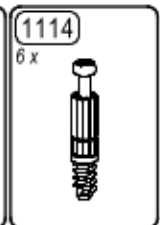
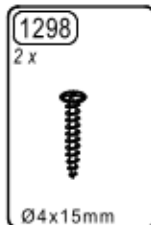
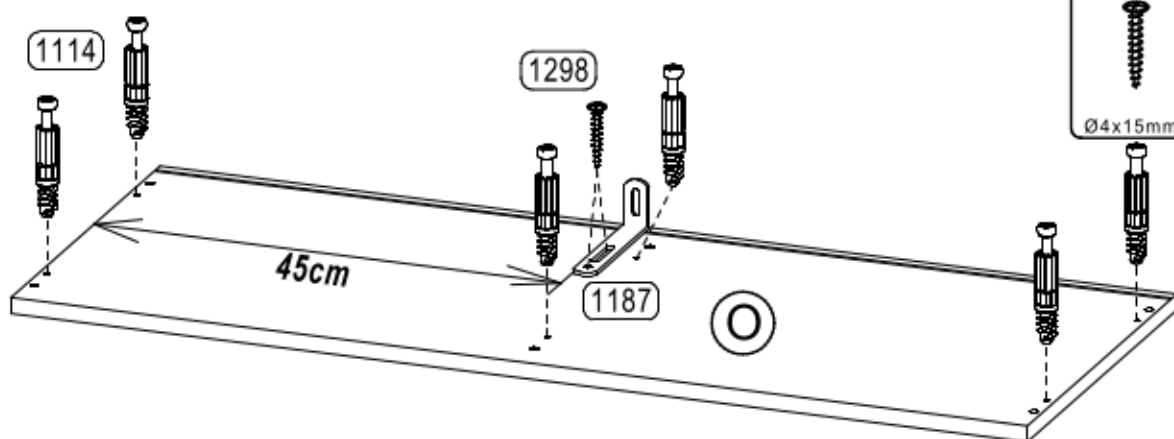

4.

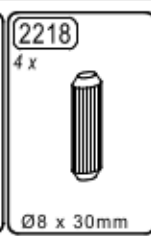
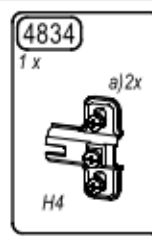
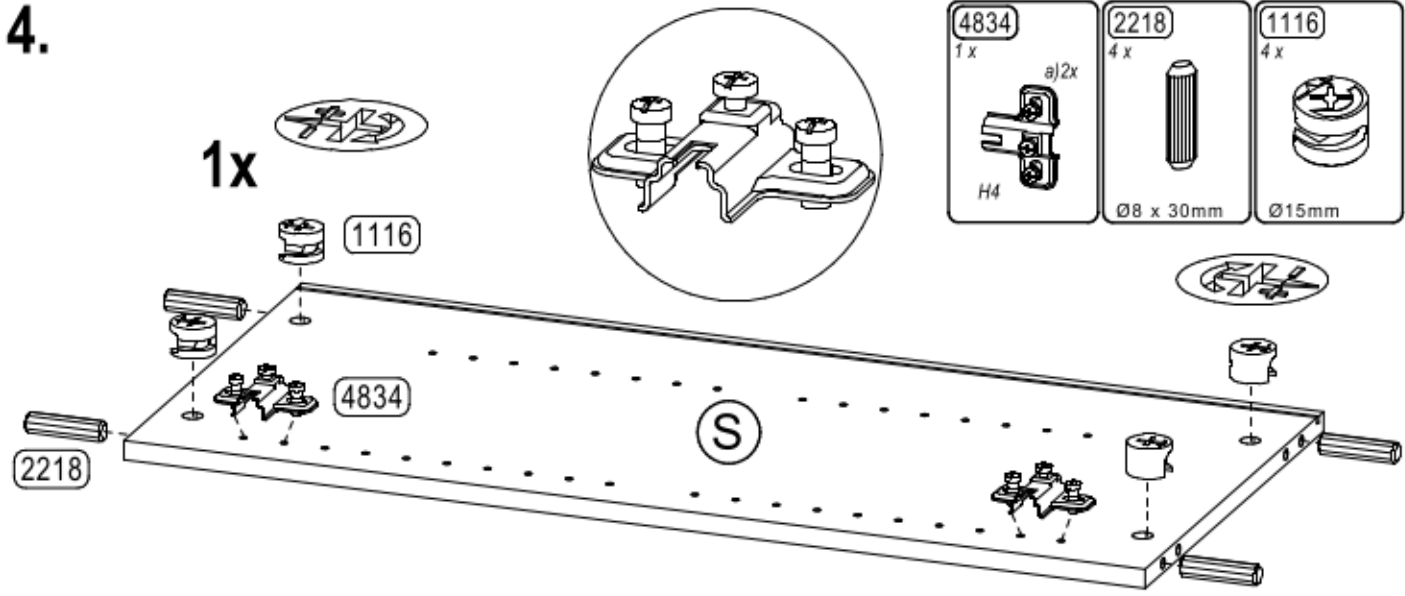

5.

5.R



?

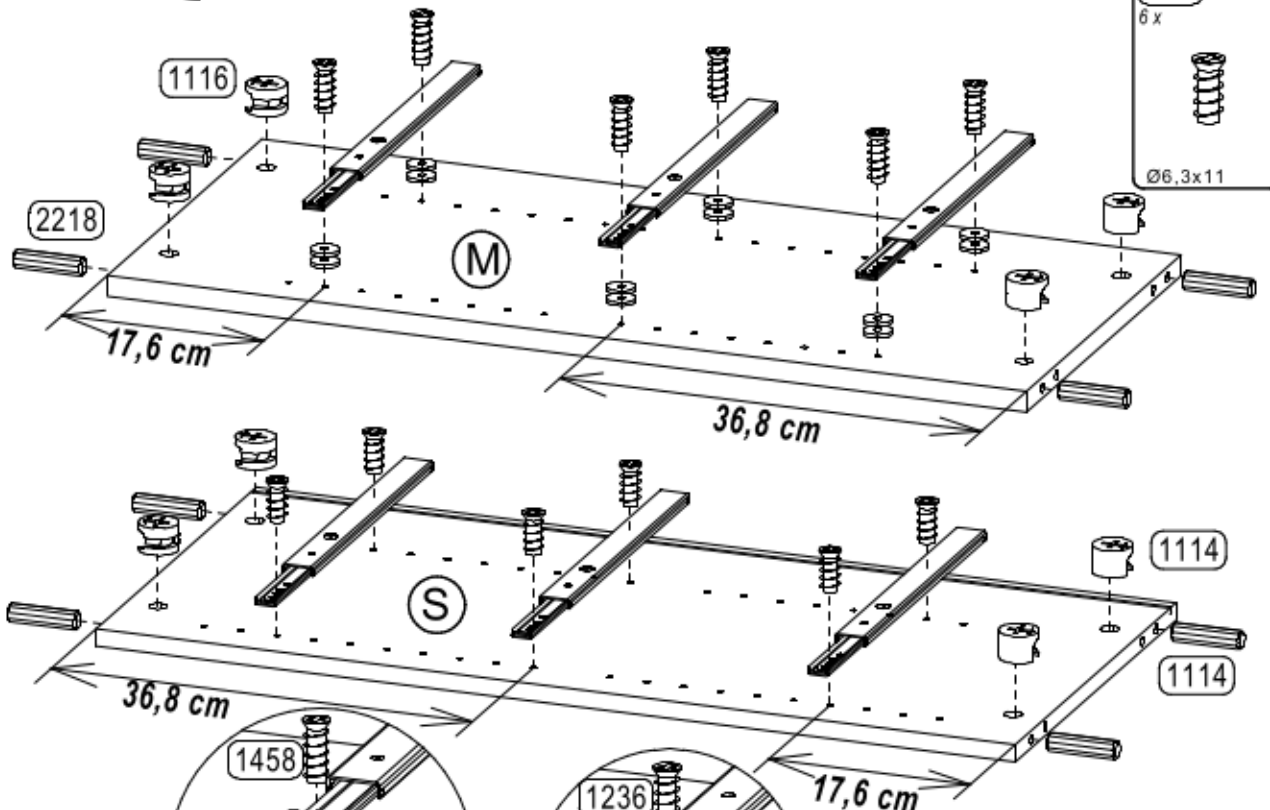
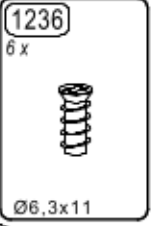
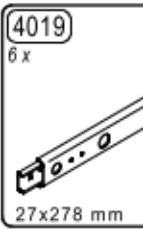
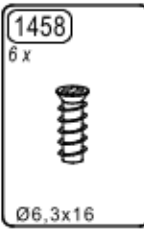
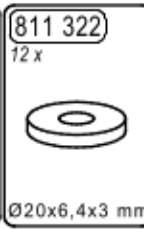
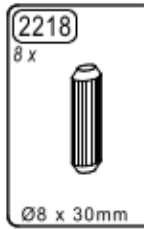

5.L



?

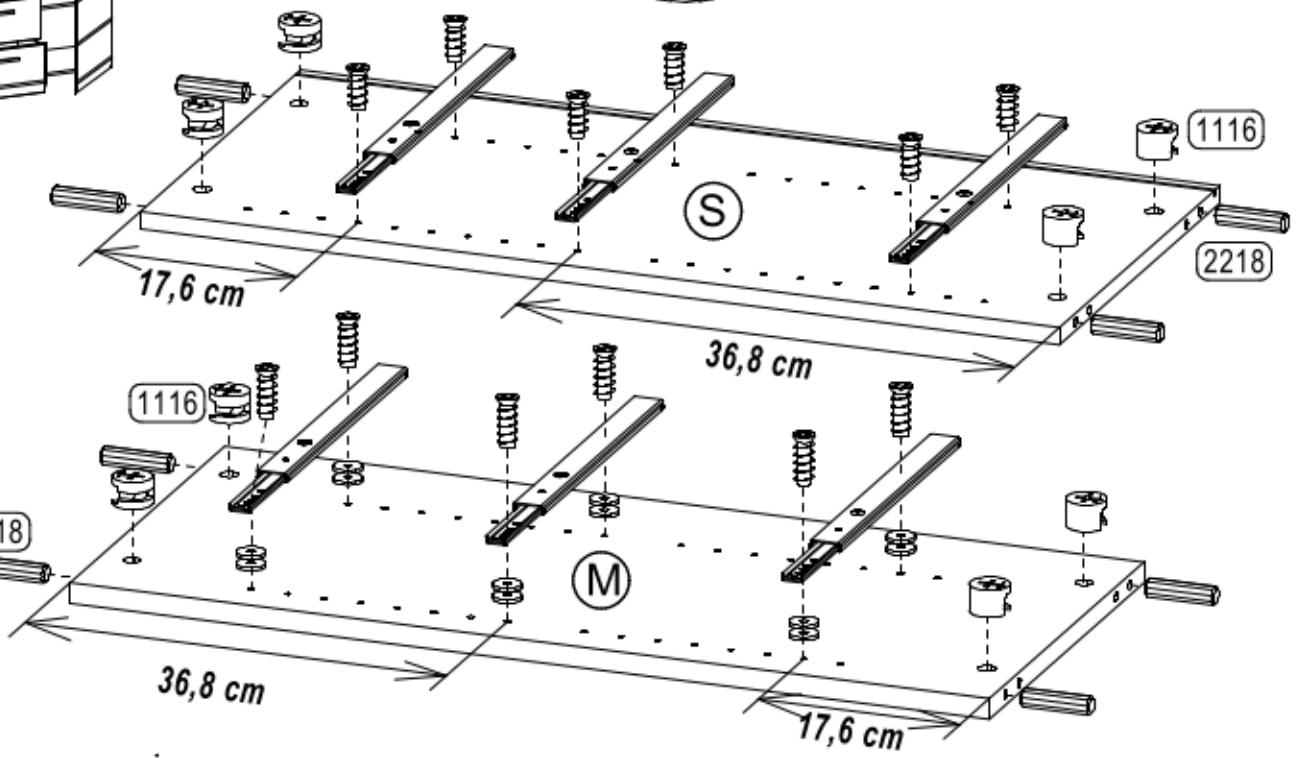

6.

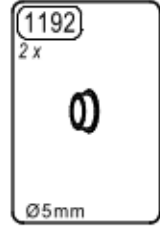
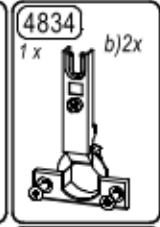
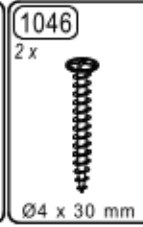
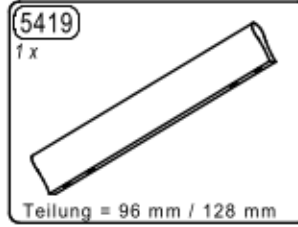
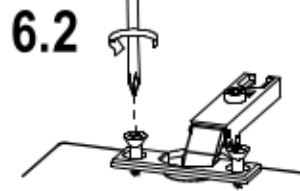
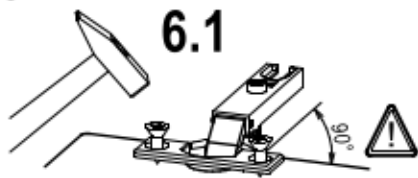

6.R

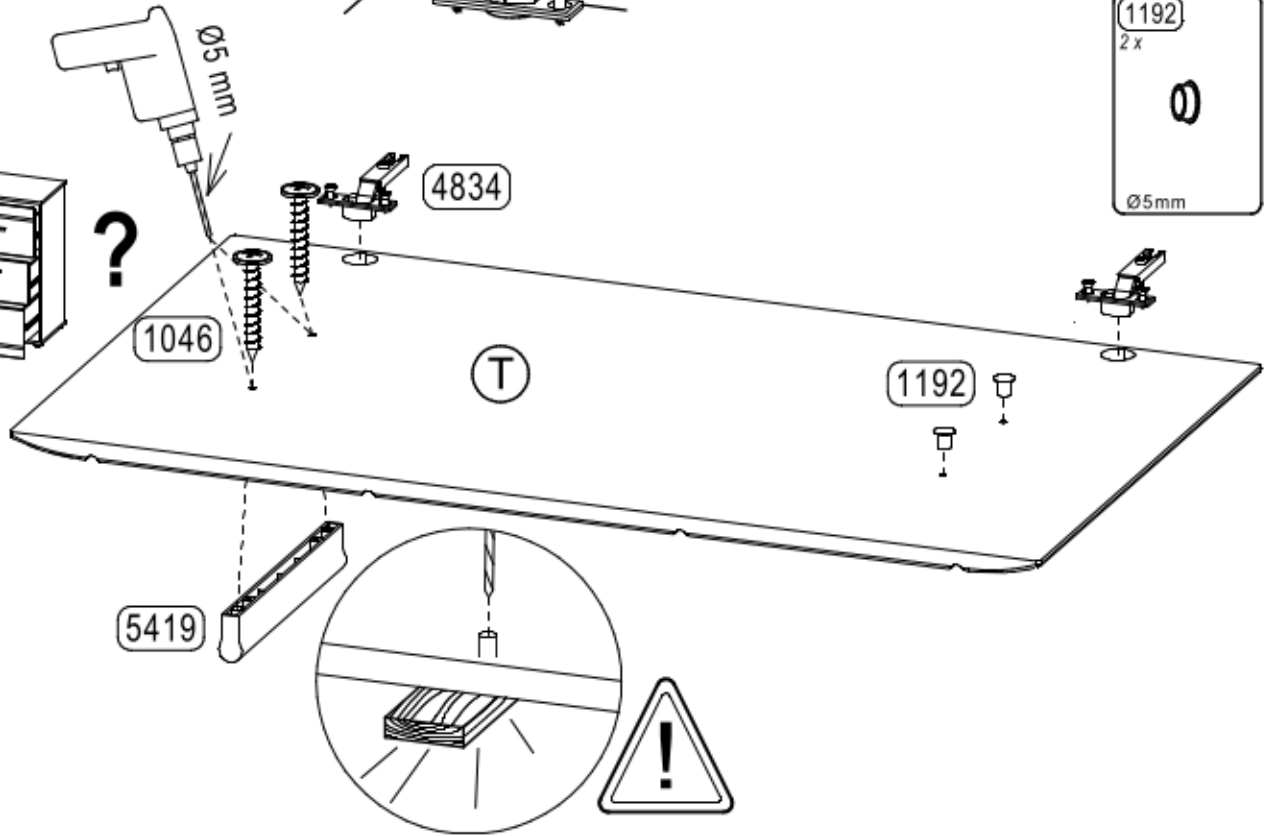

6.L

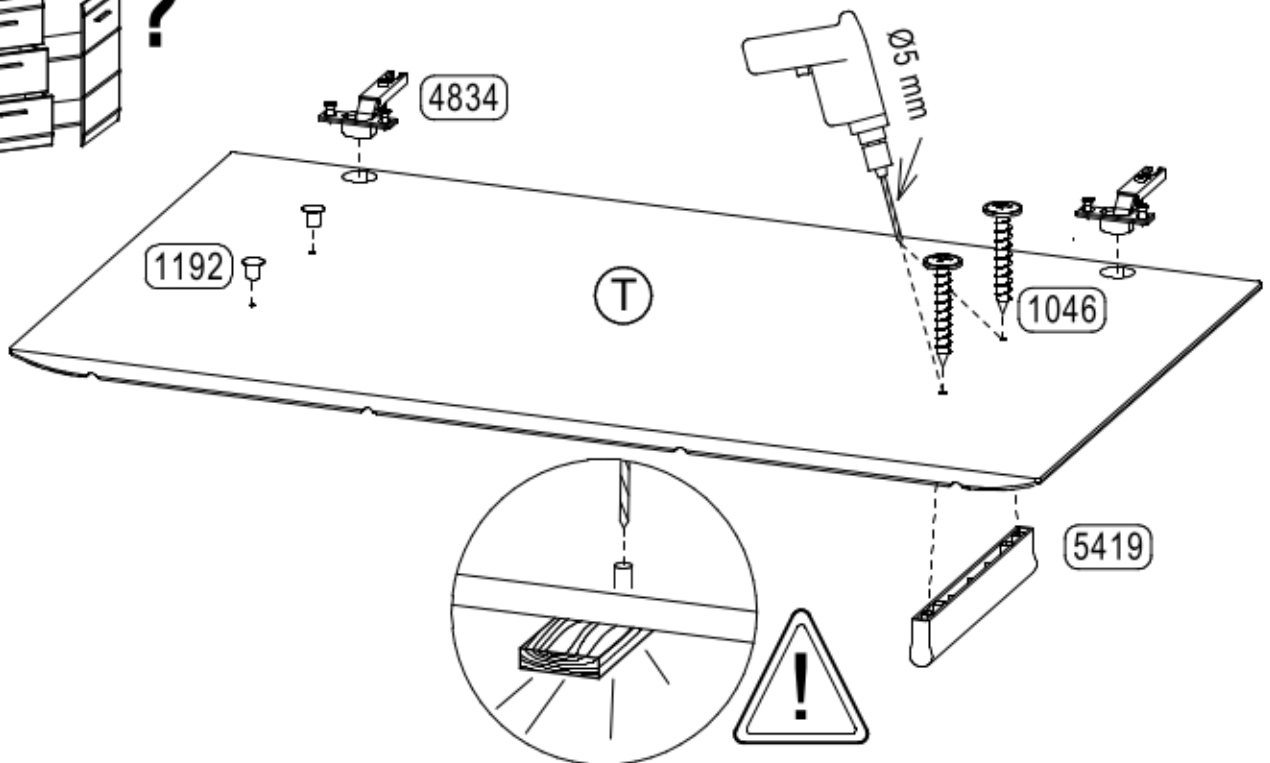

7.

7.R

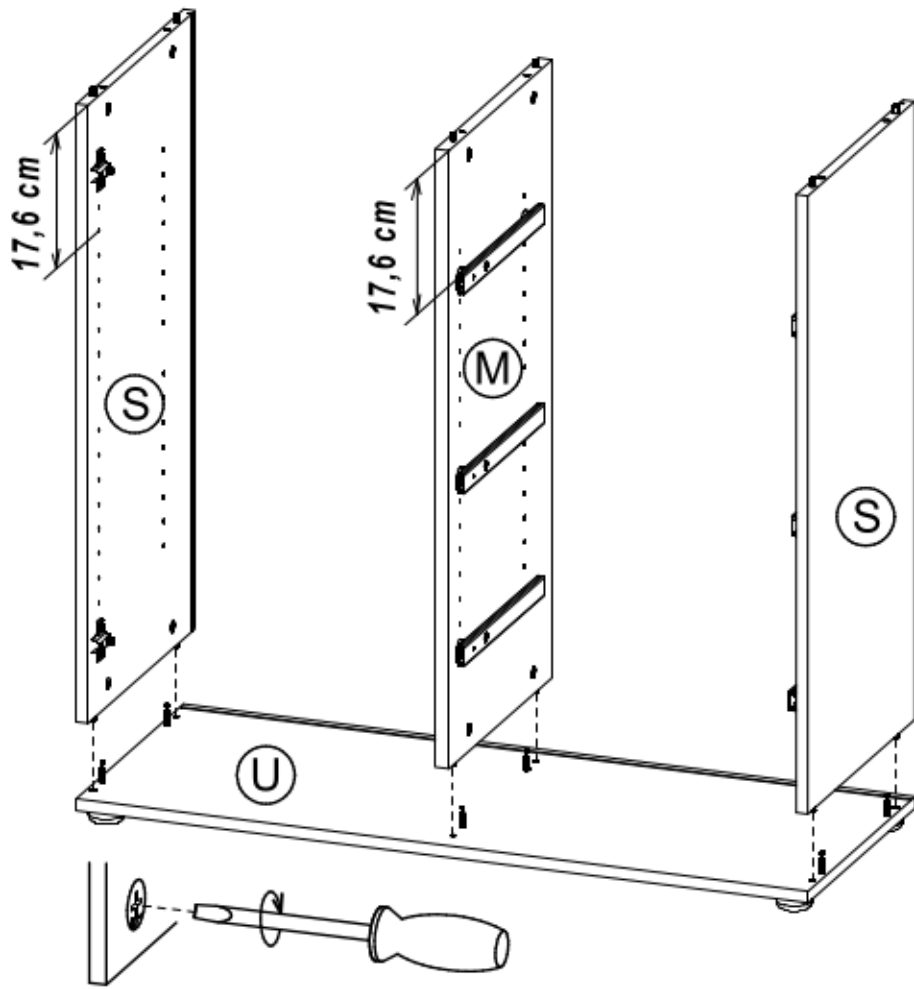
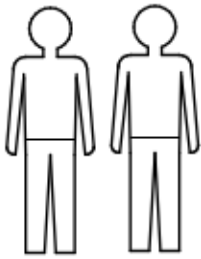

7.L

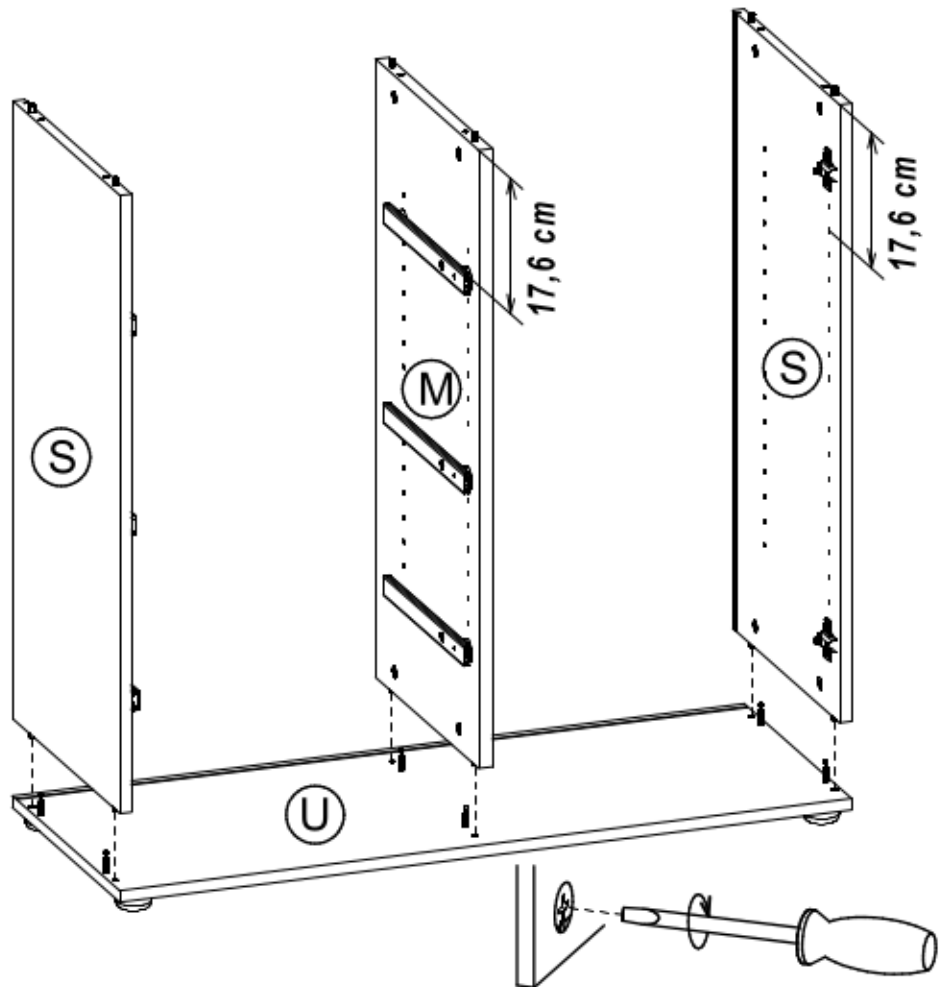

8.

8.1

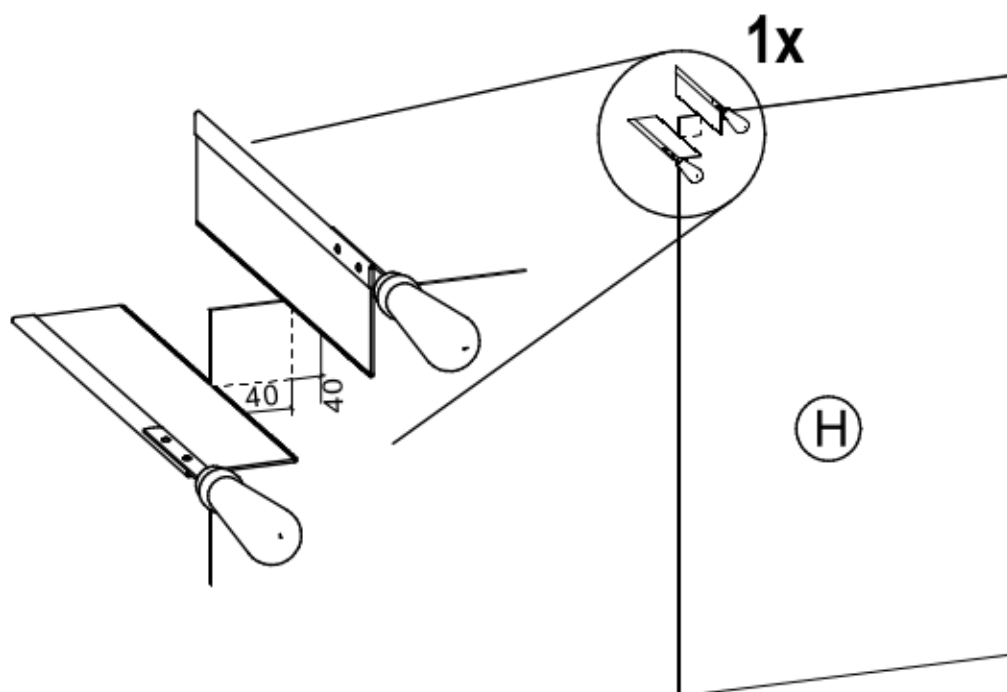

8.2

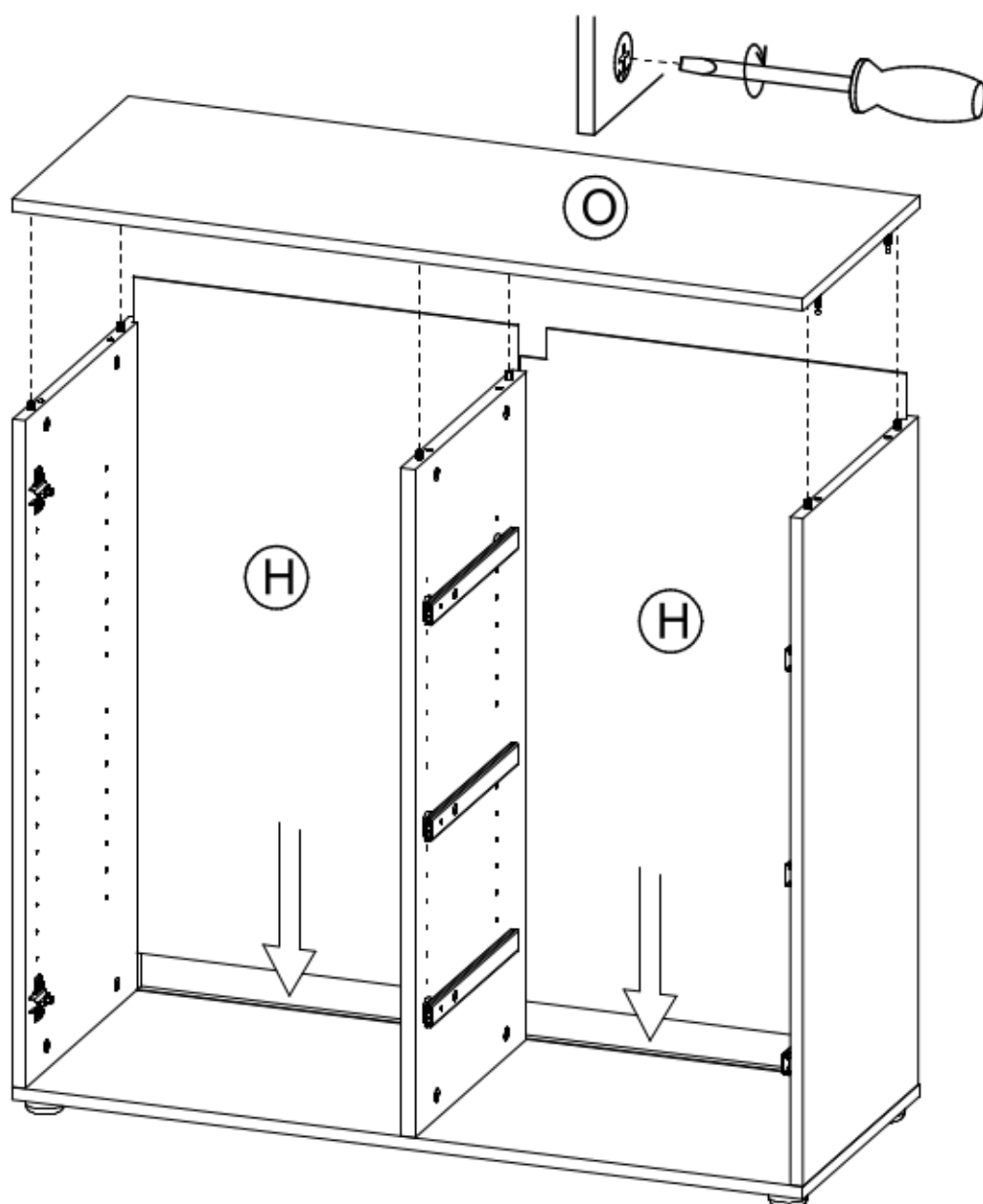
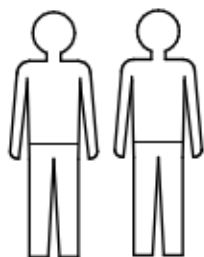

9.

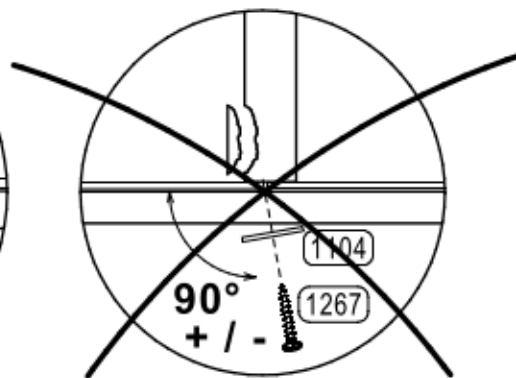
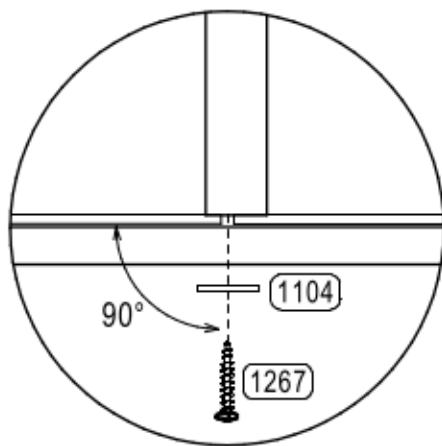
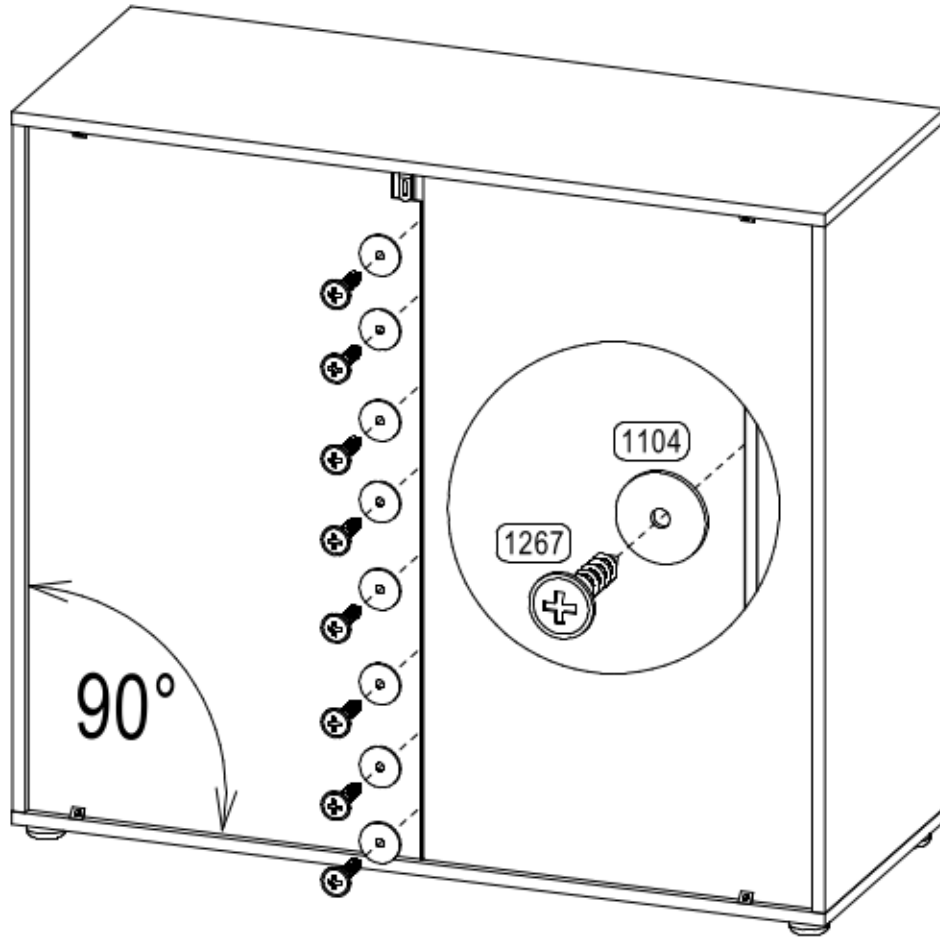
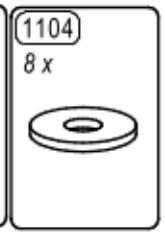
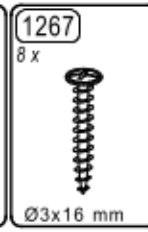
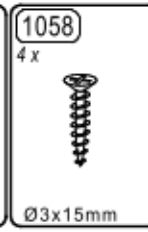
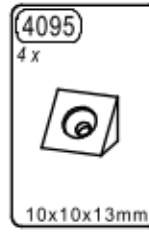
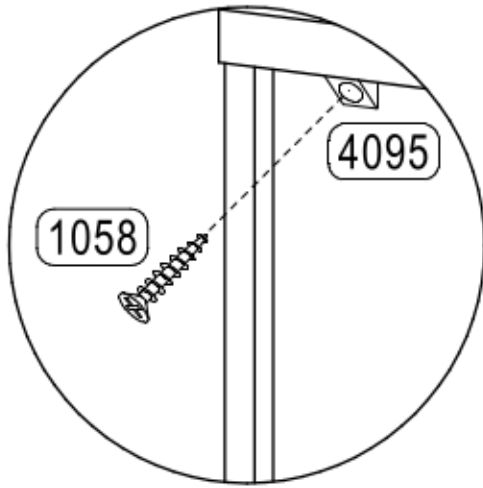

10.

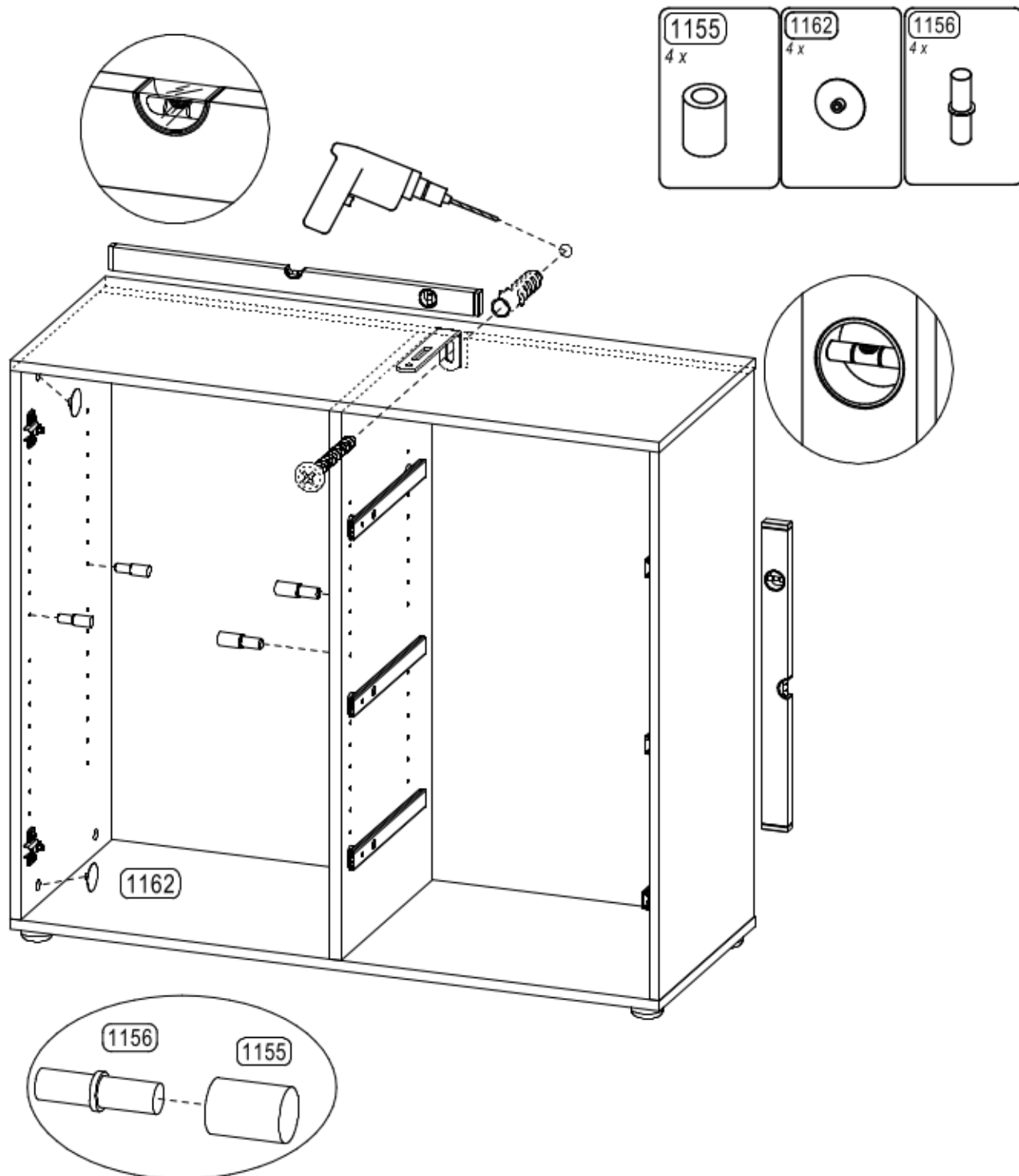
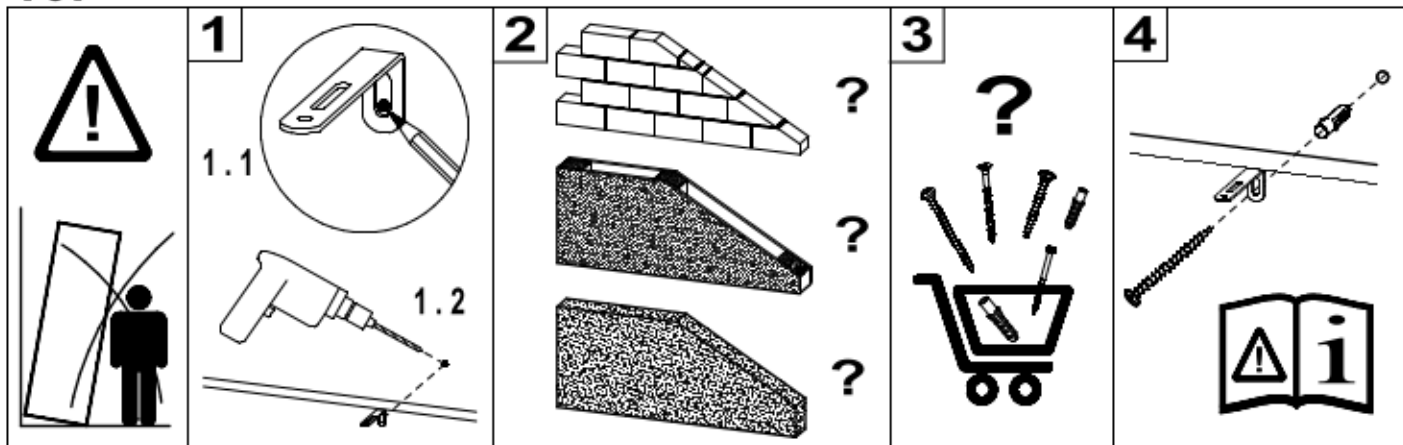

11.

11.R

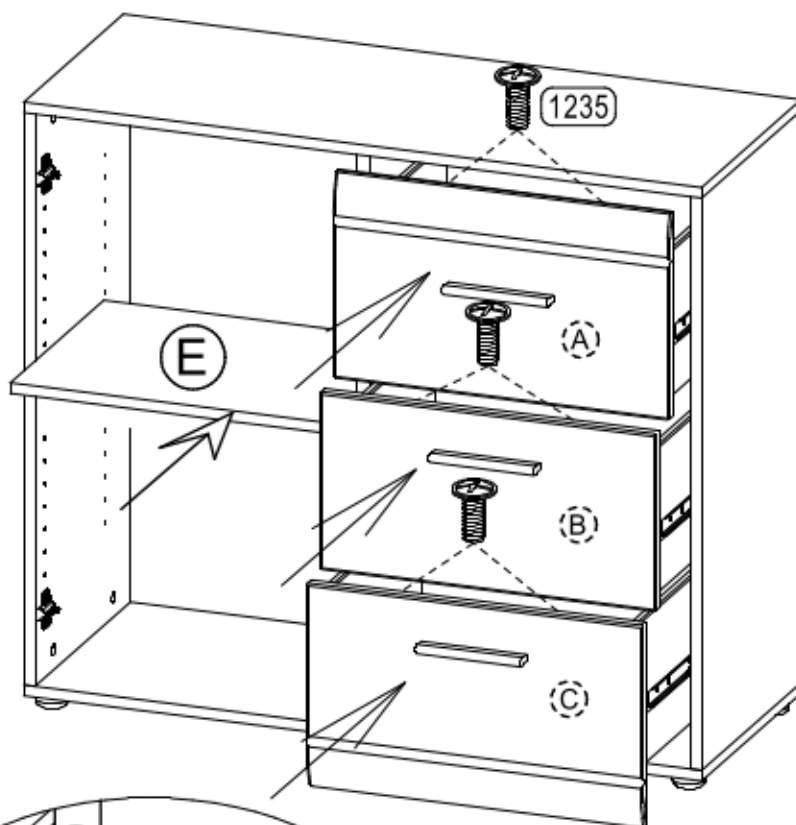

1235

6x

M4x8

11.L

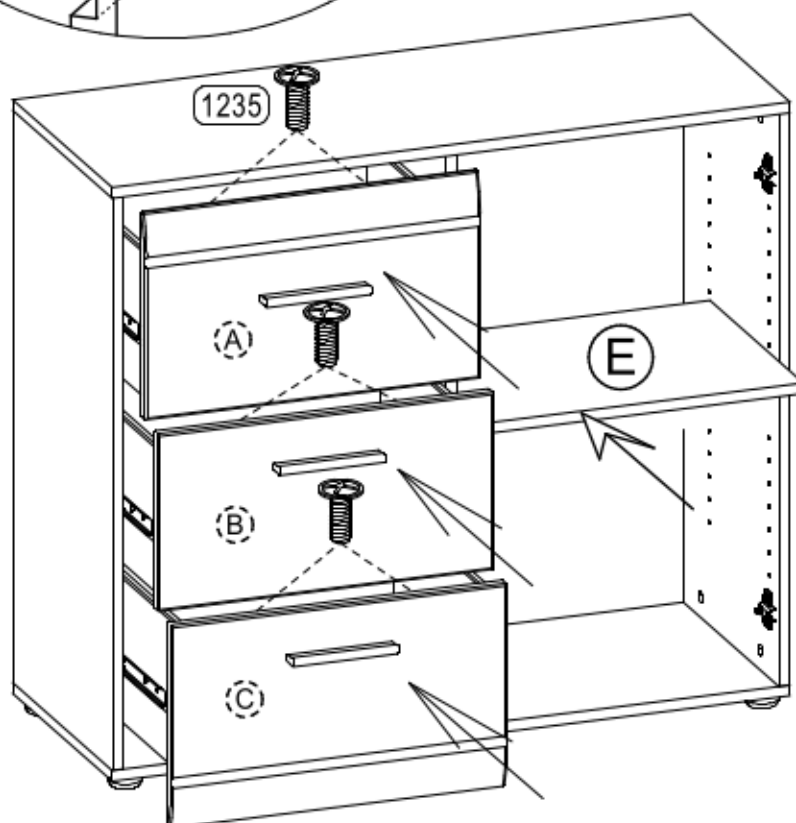
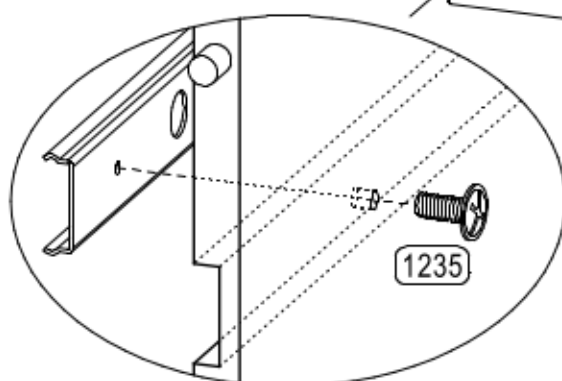

12.
12.R

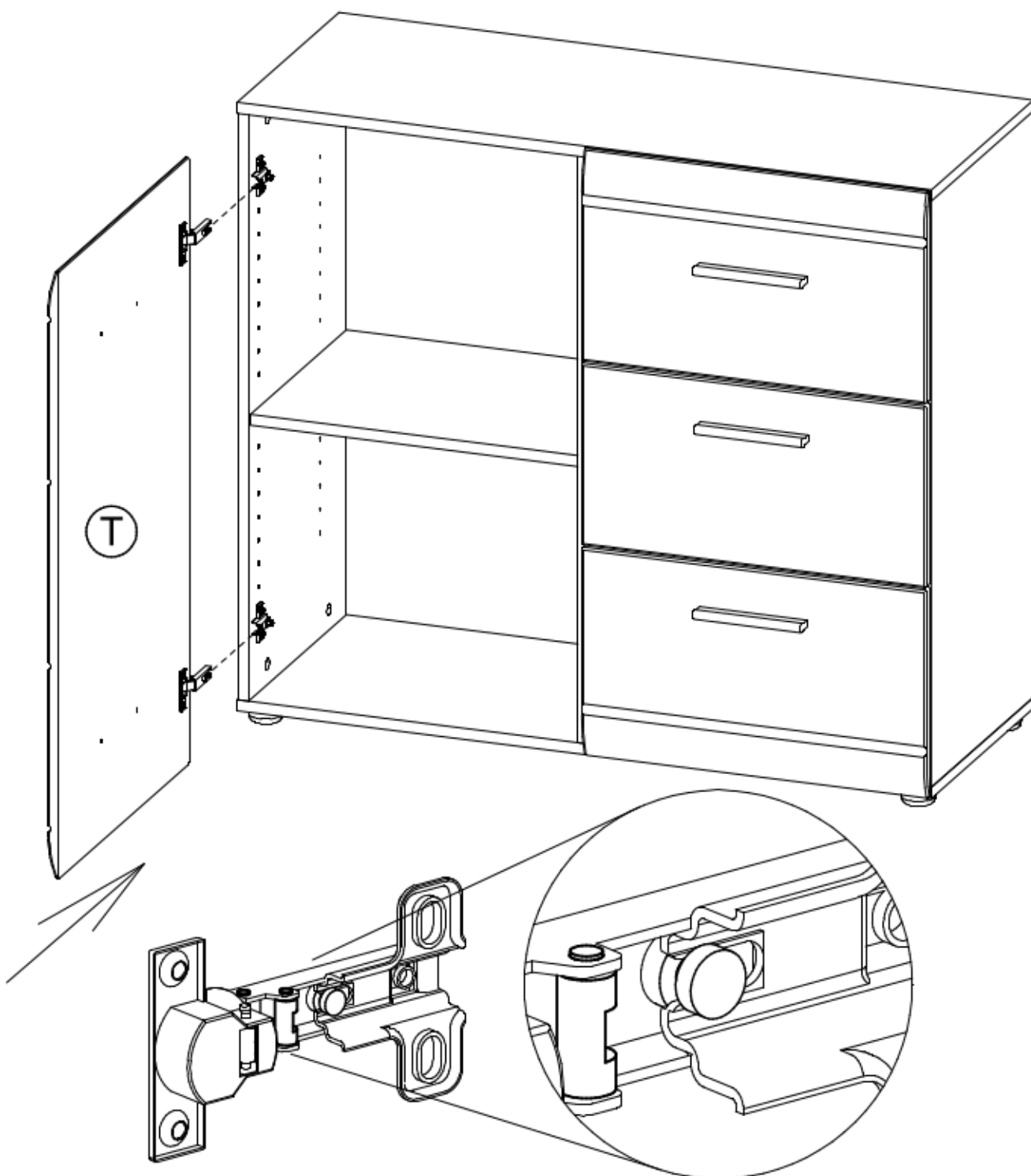

⚠ ⇒ ⓘ S. 31

12.
12.L

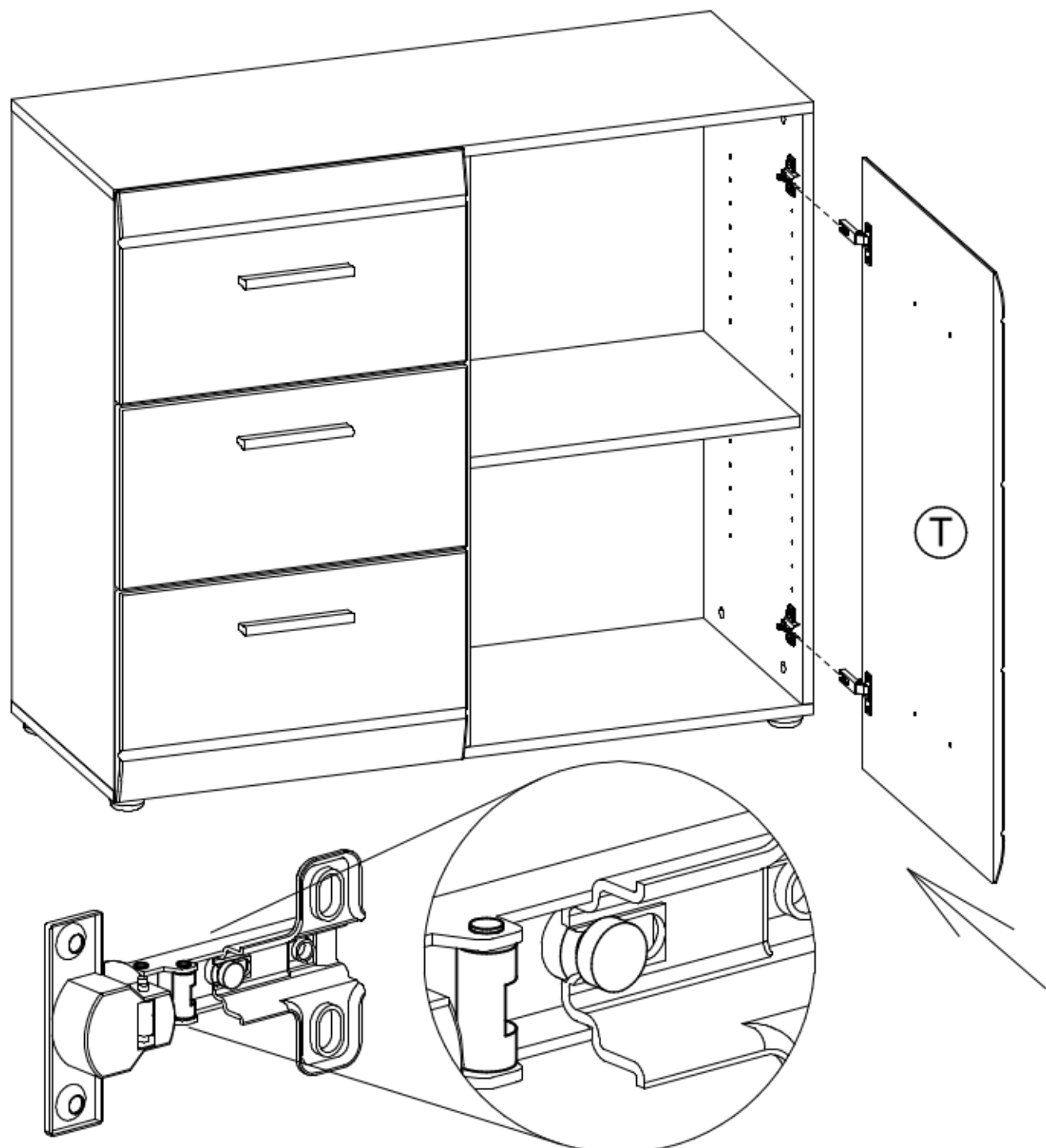

! => **i** S. 31

